

Notes:

1. All resistor values in ohms (K=1000 Ω).
2. All capacitor values in micro farads (P = μ F).
3. Schematic diagram shows both of Models R-225H and R-225J.
 Model R-225H is different from Model R-225J, and difference of Model R-225H is shown in dotted line.

Fig. 8 Circuit Board Wiring View (Conductor Side).

TR₁
2SA341
CONV.

D₁
0A90
D. AGC

TR₂
2SA101
1st IF AMP

TR₃
2SA101
2nd IF AMP

D₂
0A70
DET. & AGC

TR₄
2SB173
1st AF AMP

TR₅
2SB175
2nd AF AMP

TR₆
2SB175
3rd AF AMP

TR₇ & TR₈
2SB176 × 2
POWER AMP

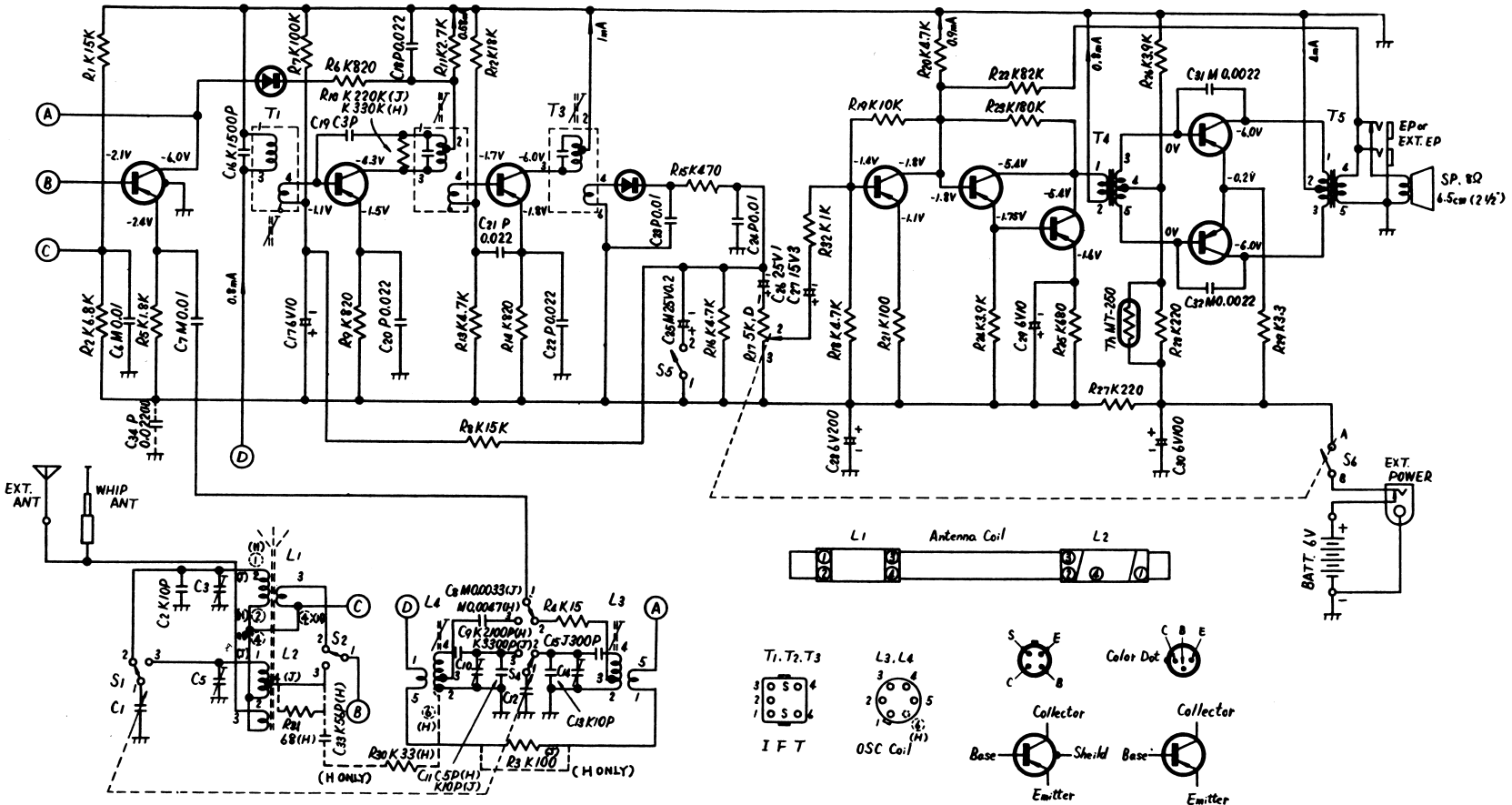

Notes:

1. S₁~S₄: Band selector switch in "MW" position.
2. S₅: Tone switch in "HIGH" position.
3. S₆: Power source switch in "OFF" position.
4. DC Voltage measurements are taken with circuit tester (10K Ω /V).
5. Measured voltages for TR₁ ~ TR₆ are from transistor terminal to positive terminal of battery.
6. Capital letters (M, K, J, P, C) in the circuit diagram show allowable tolerances of resistors and capacitors as follows:

M = $\pm 20\%$ K = $\pm 10\%$ J = $\pm 5\%$ P = $\pm 100\%$ C = $\pm 0.25PF$
 - 0%

7. Battery current: No signal..... 16mA
 Maximum output.....110mA
8. PF=pico farad=mmf
 μ F=micro farad=MF
9. Schematic diagram show both of Models R-220H and R-220J. Model R-220H is different from Model R-220J, and difference of Model R-220H is shown in dotted line.

Fig. 7 Schematic Diagram.

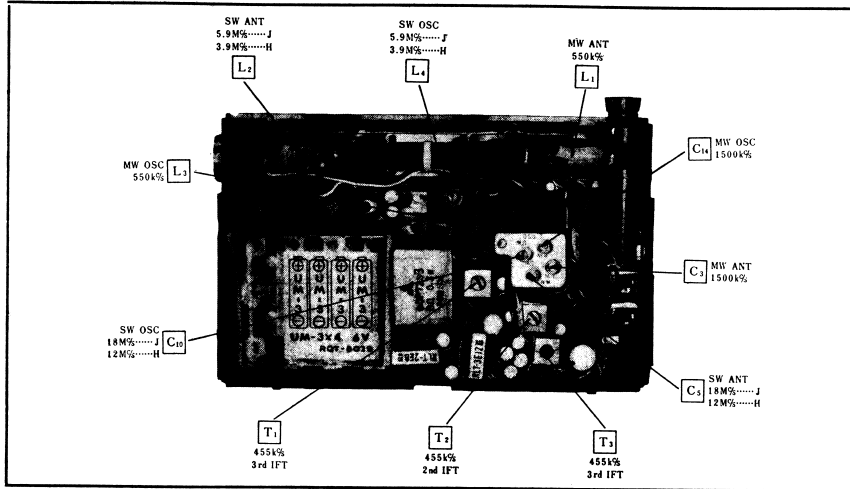
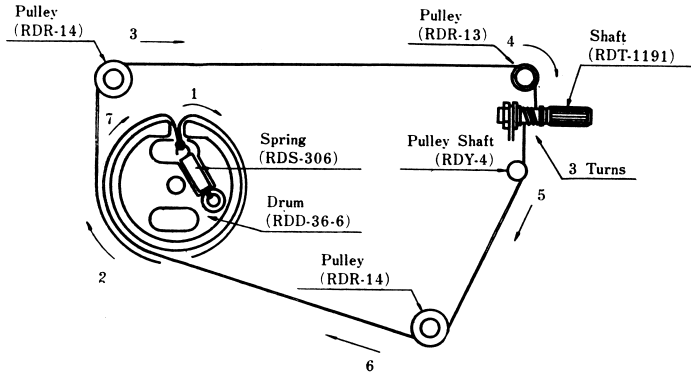

Fig. 5 Component View - Alignment Points.

Notes :

1. Arrow marks (1~7) indicate correct order and direction of stringing dial cord.
2. Tuning gang is positioned at maximum capacity.
3. Cement dial cord ends.
4. Dial cord length is 70cm (27 1/4").



To Mount Dial Pointer

1. Set tuning gauge fully closed position.
2. Set dial pointer to start point of dial back plate.
3. Fasten dial cord to dial pointer.

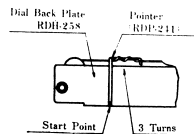

Fig. 6 Top View - Chassis Disassembly Points.

ALIGNMENT INSTRUCTIONS

Model R-225H

Output of signal generator should be no higher than necessary to obtain an output reading.
Set volume control to maximum.
Set tone switch to High.
Set power source voltage to 4.5 volts DC.

Band Switch Position	SIGNAL GENERATOR COUPLING	SIGNAL GENERATOR FREQUENCY	RADIO DIAL SETTING	INDICATOR	ADJUST	REMARKS
1	Fashion loop of several turns of wire and radiate signal into loop of receiver.	455 kc/s (400~ Mod.)	Point of non-interference. (on/about 600kc/s)	Output meter across earphone jack.	T ₃ (3rd IFT) T ₂ (2nd IFT) T ₁ (1st IFT)	Adjust for maximum output.
2	"	550 kc/s (400~ Mod.)	550 kc/s	"	L ₃ (OSC Coil) L ₁ (ANT Coil)	Adjust for maximum output by sliding coil (L ₁) along ferrite core.
3	"	1500 kc/s (400~ Mod.)	1500 kc/s	"	C ₁₄ (OSC Trimmer) C ₃ (ANT Trimmer)	Adjust for maximum output. Repeat steps (2) and (3).
4	High side thru. 10PF to EXT ANT Jack. Common to Chassis Earth	3.9 Mc/s (400~ Mod.)	3.9 Mc/s	"	L ₄ (OSC Coil) L ₂ (ANT Coil)	Adjust for maximum output by sliding coil (L ₂) along ferrite core.
5	"	12 Mc/s (400~ Mod.)	12 Mc/s	"	C ₁₀ (OSC Trimmer) C ₅ (ANT Trimmer)	Adjust for maximum output. Repeat steps (4) and (5).

Note : Cement antenna bobbin with wax after completing alignment.

Model R-225J

Output of signal generator should be no higher than necessary to obtain an output reading.
Set volume control to maximum. Set fine tuning control to center.
Set tone switch to High.
Set power source voltage to 4.5 volts DC.

Band Switch Position	SIGNAL GENERATOR COUPLING	SIGNAL GENERATOR FREQUENCY	RADIO DIAL SETTING	INDICATOR	ADJUST	REMARKS
1	Fashion loop of several turns of wire and radiate signal into loop of receiver.	455 kc/s (400~ Mod.)	Point of non-interference (on/about 600 kc/s)	Output meter across earphone jack	T ₃ (3rd IFT) T ₂ (2nd IFT) T ₁ (1st IFT)	Adjust for maximum output.
2	"	550 kc/s (400~ Mod.)	550 kc/s	"	L ₃ (OSC Coil) L ₁ (ANT Coil)	Adjust for maximum output by sliding coil (L ₁) along ferrite core.
3	"	1500 kc/s (400~ Mod.)	1500 kc/s	"	C ₁₄ (OSC Trimmer) C ₃ (ANT Trimmer)	Adjust for maximum output. Repeat steps (2) and (3).
4	Connect to EXT Antenna Jack & Chassis thru. 10PF SW Dummy Antenna.	5.9 Mc/s (400~ Mod.)	5.9 Mc/s	"	L ₄ (OSC Coil) L ₂ (ANT Coil)	Adjust for maximum output by sliding coil (L ₂) along ferrite core.
5	"	18 Mc/s (400~ Mod.)	18 Mc/s	"	C ₁₀ (OSC Trimmer) C ₅ (ANT Trimmer)	Adjust for maximum output. Repeat steps (4) and (5).

Note : Cement antenna bobbin with wax after completion alignment.

NATIONAL PANASONIC
Service Manual

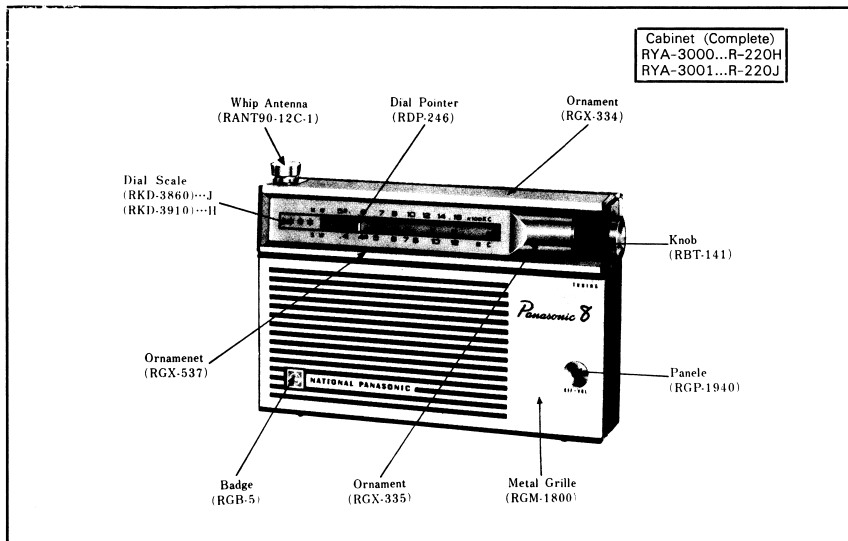
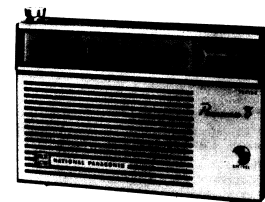

Fig. 1 Cabinet & Appearance - Parts Identification.

2-BAND 8-TRANSISTOR PORTABLE RADIO

MODEL R-220H or J



To Remove Chassis (Refer to Fig. 2)

1. Remove cabinet back cover with cabinet back cover screws.
2. Remove tuning control knob from cabinet.
3. Remove five (5) red chassis mounting screws, Nos. 1~5, as illustrated in Fig. 2.
4. To remove chassis completely, unsolder leadwires to speaker terminals.
5. To reassemble, reverse the above procedure.

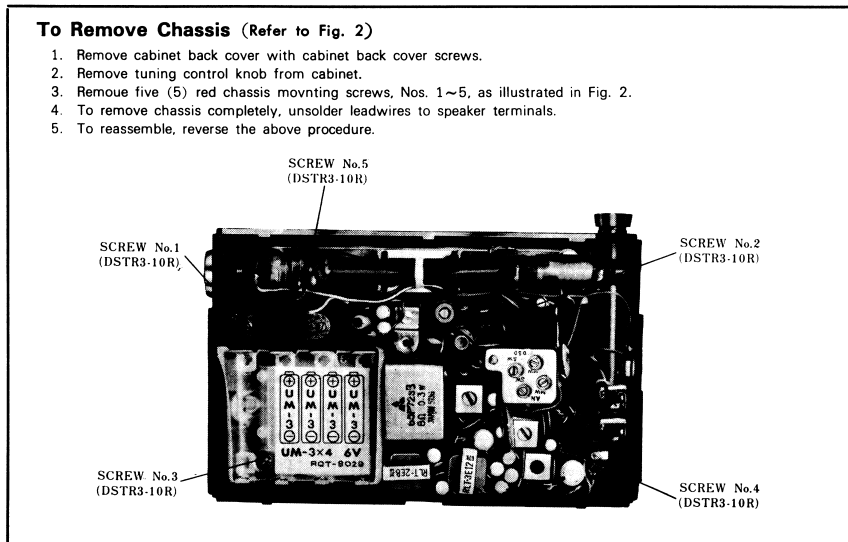

Fig. 2 Top View - Disassembly Points.

SPECIFICATIONS

Frequency Range :	MW 525~1605 kc/s (571~187m) SW 3.9~12 Mc/s (76.9~25m)...Model R-220H 5.9~18 Mc/s (50.8~16.7m)...Model R-220J
Intermediate Frequency :	455 kc/s
Transistors :	2SA341 Converter 2SA101 1st IF Amplifier 2SA101 2nd IF Amplifier 2SB173 1st AF Amplifier 2SB175 2nd AF Amplifier 2SB175 3rd AF Amplifier 2SB176 } Power Amplifier 2SB176 }
Diodes :	O A 7 0 D. AGC O A 7 0 Detector & AGC
Sensitivity :	MW 50 μ V/m for 50mW Output SW 50 μ V/m for 50mW Output Model...R-225H 70 μ V/m for 50mW Output Model...R-225J
Power Output :	200mW Undistorted 350mW Maximum
Speakers :	6.5cm (2 $\frac{1}{2}$ ") PM Dynamic Speaker
Batteries :	Four "AA" size penlight batteries, 6V (NATIONAL UM-3 or equivalent)
Cabinet Dimensions :	164 (Wide) \times 106 (High) \times 42 (Deep) mm (6 $\frac{1}{2}$ " \times 4 $\frac{1}{4}$ " \times 1 $\frac{1}{2}$ ")
Weight :	570g (1 lb. 4 oz.) with batteries