



## TECHNICAL BULLETIN

SUBJECT-

INSTALLATION INSTRUCTIONS

for fitting

MODEL "CR" 6 VALVE 6 VOLT CAR RADIO INTO THE 1949-50 PONTIAC CARAntenna

The antenna used is a four section telescopic whip type which is mounted on the car fender (mudguard) in the position shown in the diagram.

1. Centre punch the mark and drill a 1 1/8 in. dia. hole. Clean off all paint, grease and burrs for approx. 1/2 in. on the underside of the hole with a sharp-edged tool or emery paper to ensure proper electrical earthing of the clamp washer.
2. Remove the lead-in, lock nut, clamp ball and clamp washer from the antenna base. Insert the antenna base into the top of the hole. Hold the antenna vertical and turn the formed rubber washer on the antenna base so that it fits the form of the fender.
3. On the underside of the fender, reassemble the clamp washer, clamp ball and lock nut to the antenna base. Tighten the lock nut securely, making sure the antenna remains vertical, and the formed rubber washer follows the form of the fender.
4. Reassemble the lead-in cable to the base of the antenna, making sure the knurled gland nut on the lead-in is securely tightened.

Assembly of Sub Unit to Receiver Case

1. Remove knobs, small barrel nuts, escutcheon and large barrel nuts from sub unit spindles.
2. Remove rear cover of sub unit by unscrewing the six self tapping screws around the outer edges.
3. Insert 7 pin plug lead and shielded lead from receiver through large hole in sub unit rear cover, then fasten the rear cover to front of receiver case with four 1/4 in. x 5/32 in. dia. whit. screws and S/P. washers.
4. Insert a small screwdriver through hole in receiver can into rubber moulding on condenser gang shaft and turn fully clockwise.
5. Connect lug on end of shielded A+ lead from receiver under head of screw in corner of 7 pin socket on sub unit. Fit 7 pin plug on to 7 pin socket.
6. With the pointer in extreme clockwise position insert splined end of tuning spindle into rubber moulding on condenser gang.
7. Re-assemble sub unit to its rear cover on receiver with the six self tapping screws.

Installation of Receiver and Speaker Into Car

1. Viewing the car from the front, drill from the engine side of the firewall or bulkhead an 11/32 in. dia. hole 1 in. below centre of right hand horn bottom mount bolt and a 1/4 in. to the left.
2. Remove escutcheon from car instrument panel.
3. Loosen off 5/16 in. nut on rear of set mount bolt-do not remove it completely.
4. Insert receiver up behind instrument panel-control spindles to protrude through holes in panel.
5. Clamp unit in position by fitting to control spindles the two large barrel nuts, finger tight.

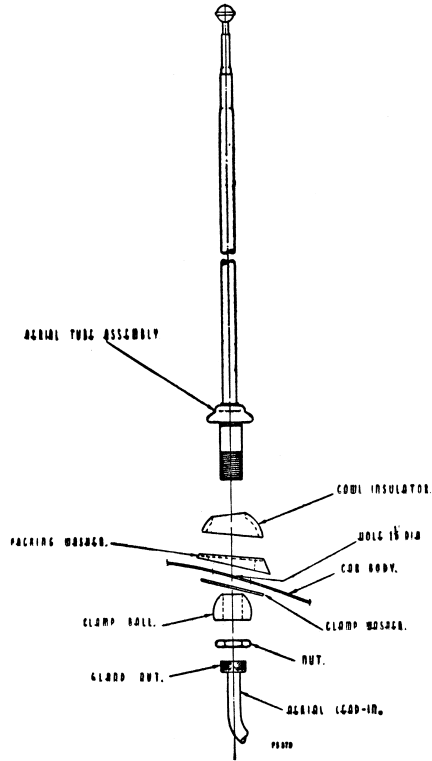

**BONNET**

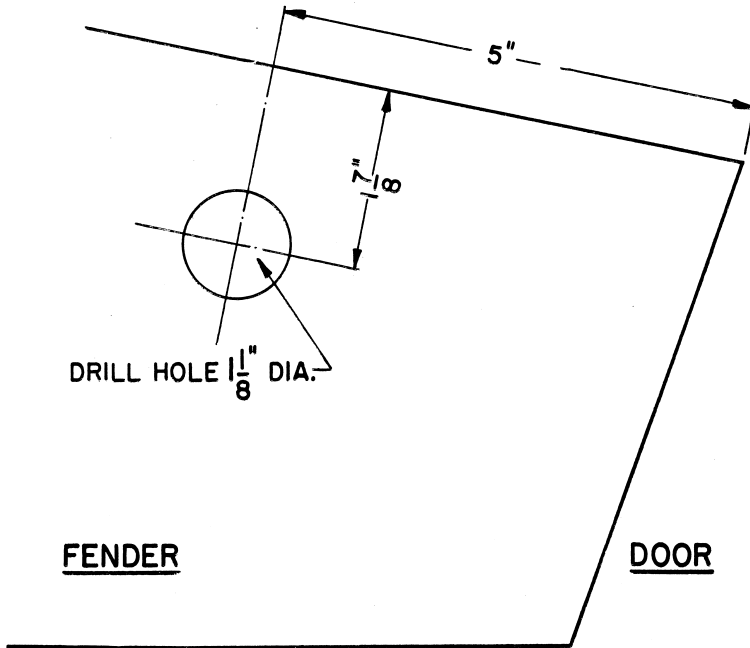

**TOP VIEW OF LEFT HAND SIDE FENDER SHOWING POSITION OF AERIAL MOUNTING HOLE**

Installation of Receiver and Speaker into Car—Continued.

6. Fit speaker baffle in position behind speaker grille on instrument panel, the slots in the lugs on speaker baffle ends fit over the two spacers either end of control unit.
7. Fit receiver rear support stay in position by sliding slotted section over receiver rear mount bolt (refer diagram) and the tongue on the opposite end fits into top fold of baffle.
8. Securely tighten nut on receiver rear mount bolt and large barrel nuts on control spindles.
9. Insert 5/16 in. bolt through bottom hole in rear support stay and firewall and securely tighten.
10. Fit escutcheon, small barrel nuts and tighten securely; fit push-on knobs.
11. Connect speaker lead plug to receiver speaker socket. Connect antenna lead-in to receiver lead-in socket. Connect A+ lead from receiver sub unit to battery side of ammeter.

Interference Elimination

1. No spark plug suppressors are required.
2. Distributor Suppressor:—Remove the high tension lead from the distributor cap and into its place fit a plug-in type suppressor. On to the HT. lead fit the rubber cap supplied, connect HT. lead into outer end of suppressor and slip rubber cap over the connection.
3. Mount a .5 MFD. metal clad by-pass condenser on the generator under the head of the screw provided for this purpose. Connect the lead from the condenser to the armature terminal, not the field terminal—make the lead as short as possible.
4. Mount a .5 MFD. metal clad by-pass condenser under the head of the bolt fastening the coil mount clip. Connect the lead from the condenser to the battery terminal of the coil—make the lead as short as possible.

The nuts and mounting positions of the by-pass condensers must be entirely free of grease, insulating varnish or paint to ensure a proper electrical contact.

Parts List

	<u>Part No.</u>
Antenna	: Antenna only, less lead-in, fully extended 49", fully retracted 15" M223
Antenna Lead-in	: 48" overall length M224
Tone Control	: 100K. ohm. PR678
Volume Control	: .5 megohm PR679
Speaker	: 6" x 9" oval type (speaker only with 2 only 24" leads, less shielding braid and plug) K158
Speaker Plug	: 2 pin 336/30C
Dist. Suppressor	: Plug-in type, 6 volt PR221
Rubber Cap	: For fitting over suppressor connection 14/140
Fuse	: 15 amp. PM219
Dial Pointer	: A104/325-2
Control Knob	: 4/310-2
Knob Spring	: 86/71
7 Pin Socket Assy.	: On remote control head A104/323
7 Pin Plug Assy.	: On receiver lead A104/58-1
Barrel Nut	: Small type 9/325
Barrel Nut	: Large type 13/325
Escutcheon	: 17/325-1
No. 6 PK. Screw	: 35/560-2
Dial Reading	: 14/665-3
Dial Lamp	: 6-8V. 0.3A. min. bay. base G3½ bulb M127
Thumb Wheel	: 3/306-1
Rear Mount Bolt	: Bracket to firewall 48/560-18
Rear Mount Nut	: Bracket to firewall 3/478-14
By Pass Cond.	: .5MFD. 200V. DCW. Metal clad PC545

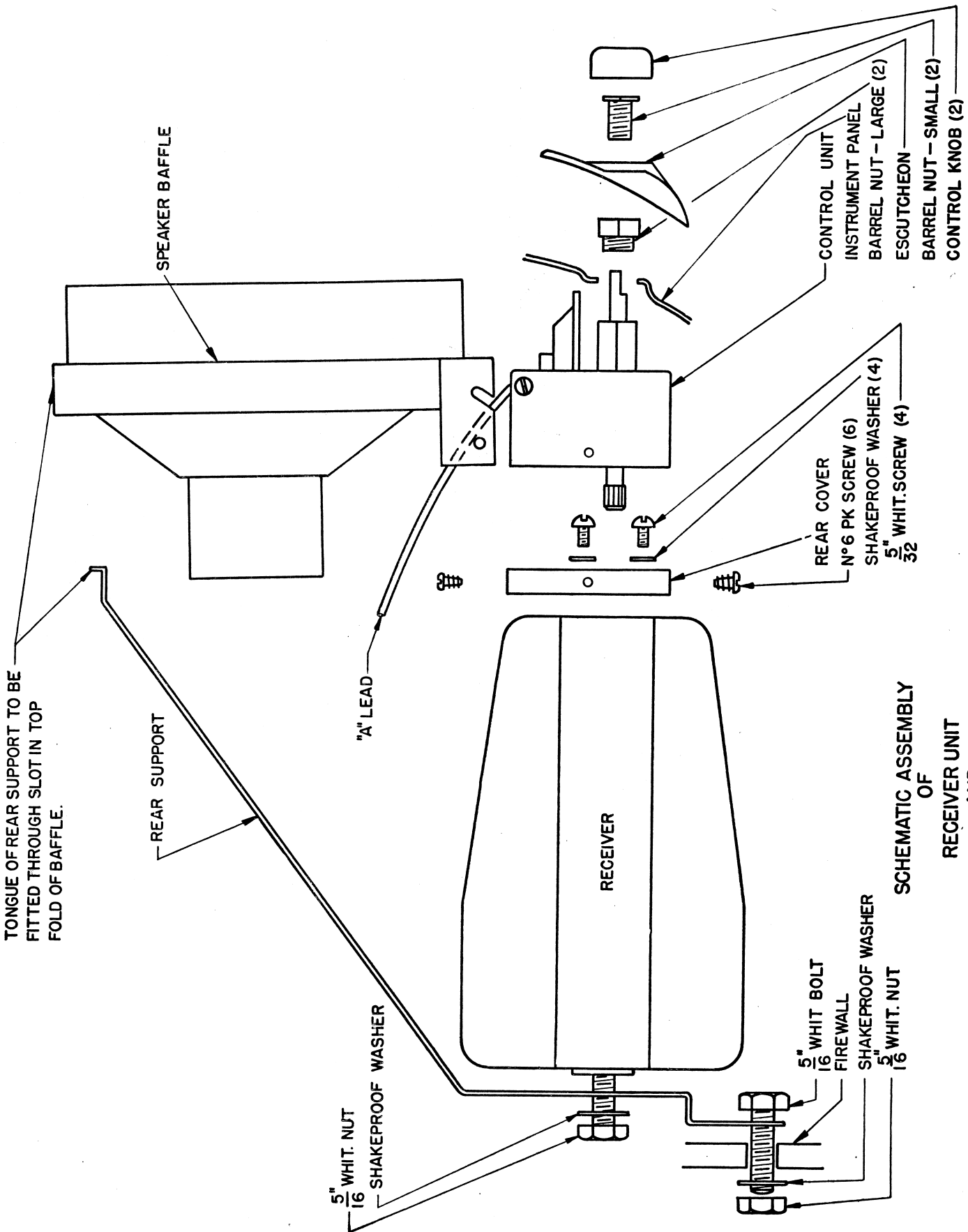

SCHEMATIC ASSEMBLY  
OF  
RECEIVER UNIT  
AND  
MOUNTING IN PONTIAC