

Young Chang R&D Institute
 1432 Main St.
 Waltham MA 02451
 USA
 Copyright 2006 Young Chang Co., Ltd.
 Reproduction without the express written consent of Young Chang Co., Ltd. is prohibited.

Title: PC3 ENGINE BOARD ASSEMBLY
 SH7705 CPU and Memory

Size	By	Document Number	Rev
	R. Folk	021304-00A	RAV2

Date: Monday, April 23, 2007 Sheet 1 of 9

MARA 2 DECOUPLING CAPS

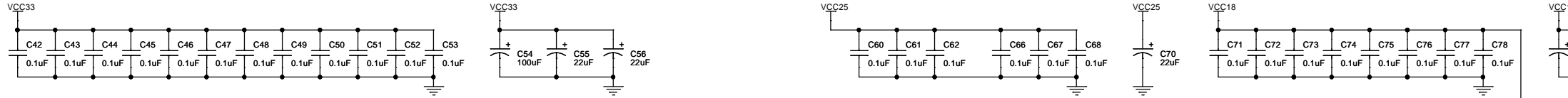

MARA 2

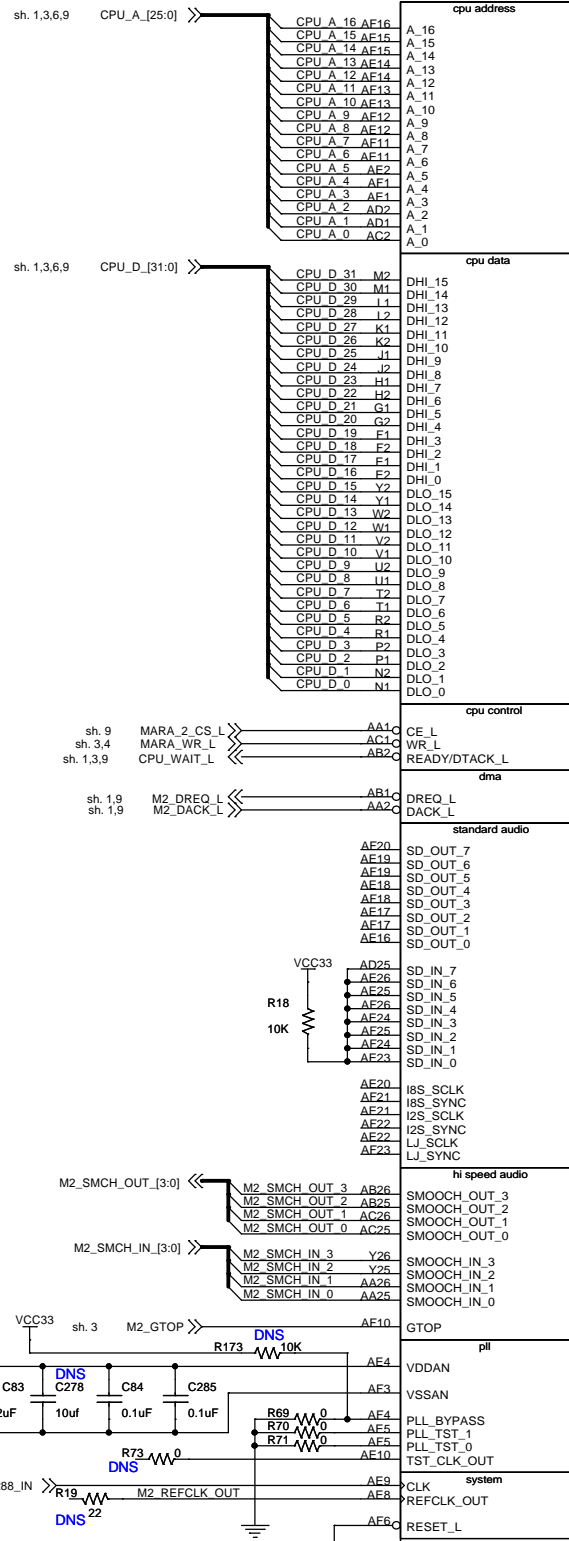

MARA

U10

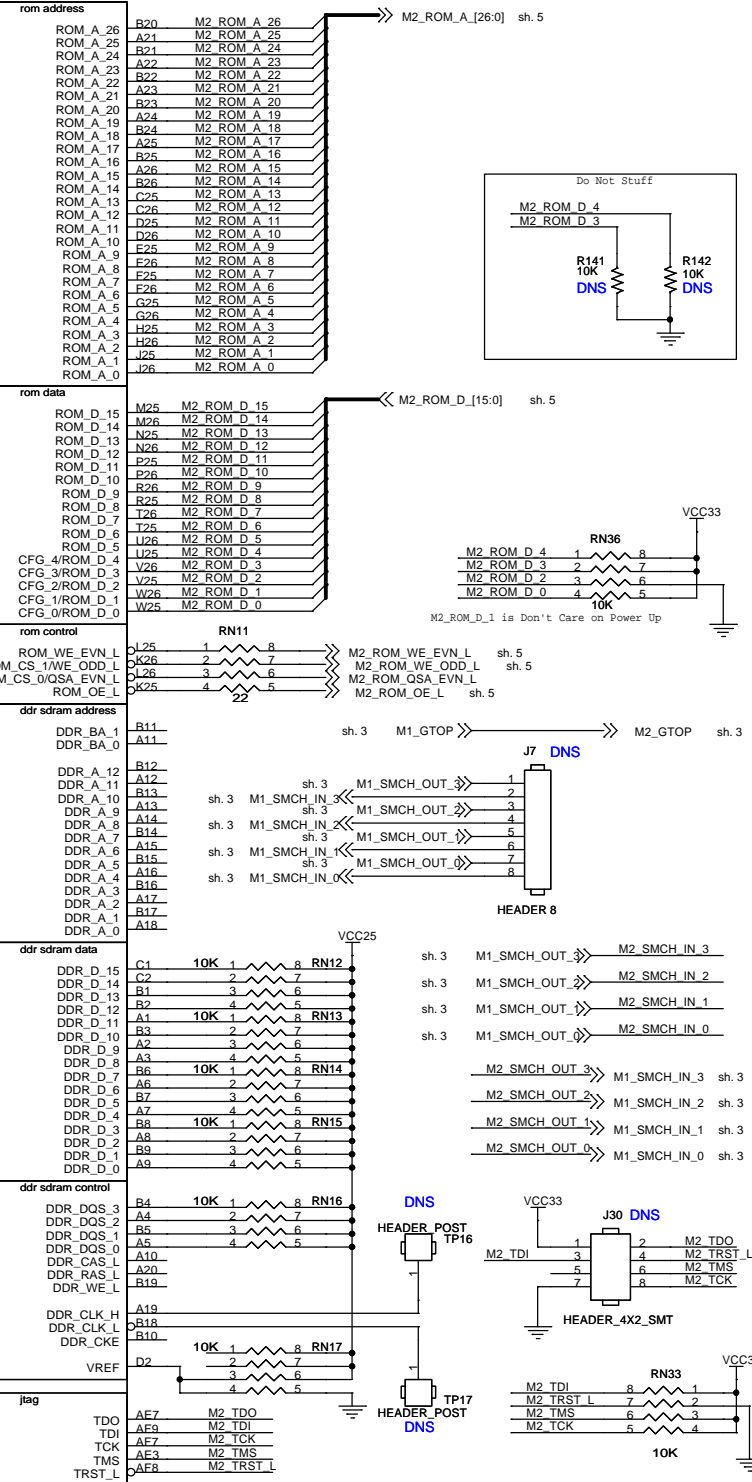
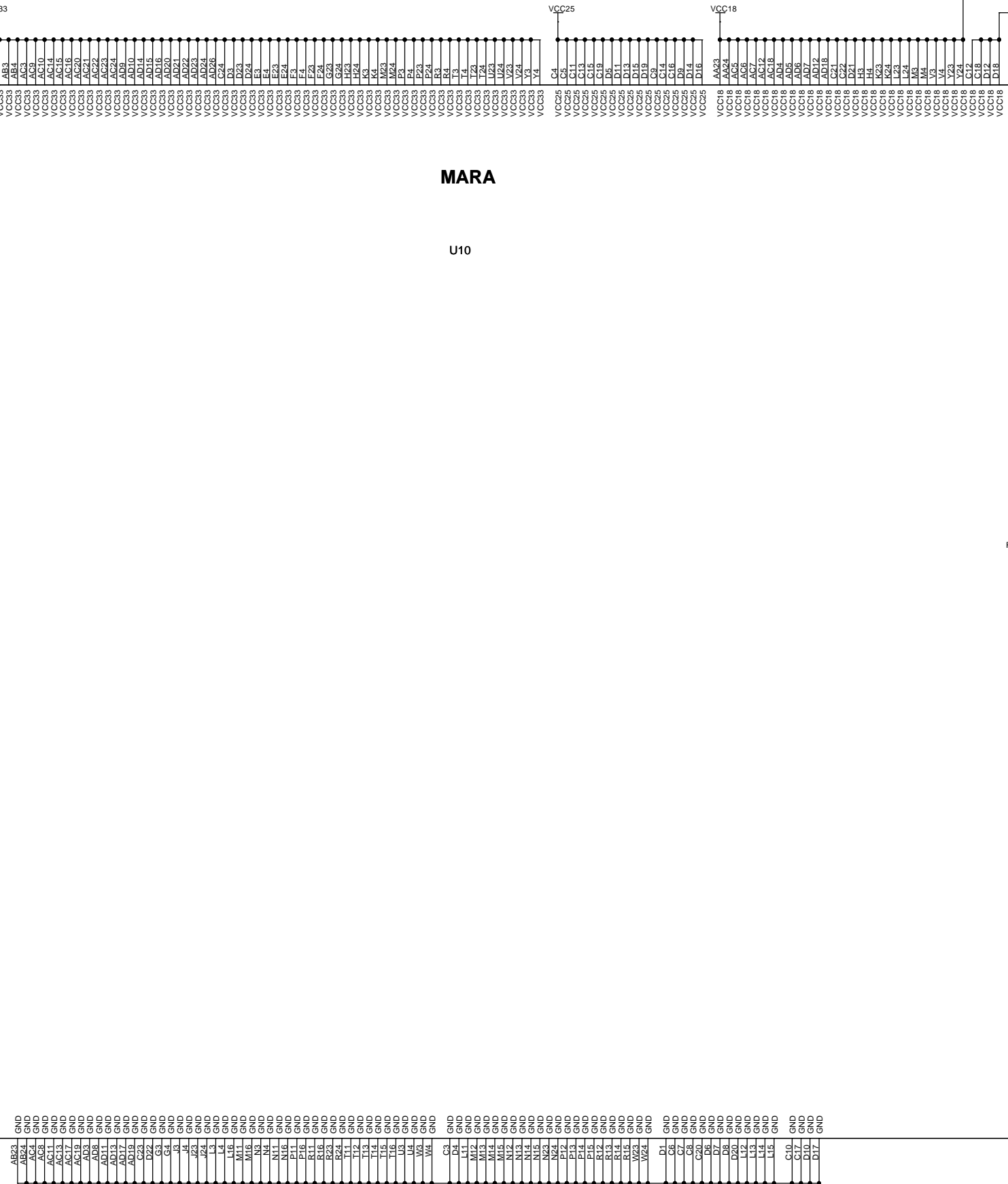

Young Chang R&D Institute
1432 Main St.
Waltham MA 02451
USA
Copyright 2006 Young Chang Co., Ltd.
Reproduction without the express written consent of Young Chang Co., Ltd. is prohibited.
Title: PC3 ENGINE BOARD REV. 2 ASSEMBLY
MARA 2
Size: R. Folk
By: R. Folk
Date: Friday, April 20, 2007
Document Number: 021304-00A
Rev: RAV2
Sheet 2 of 9

MARA 1 DECOUPLING CAPS

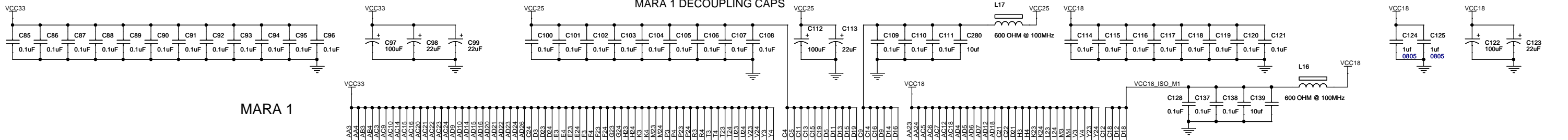

MARA 1

MARA

U11

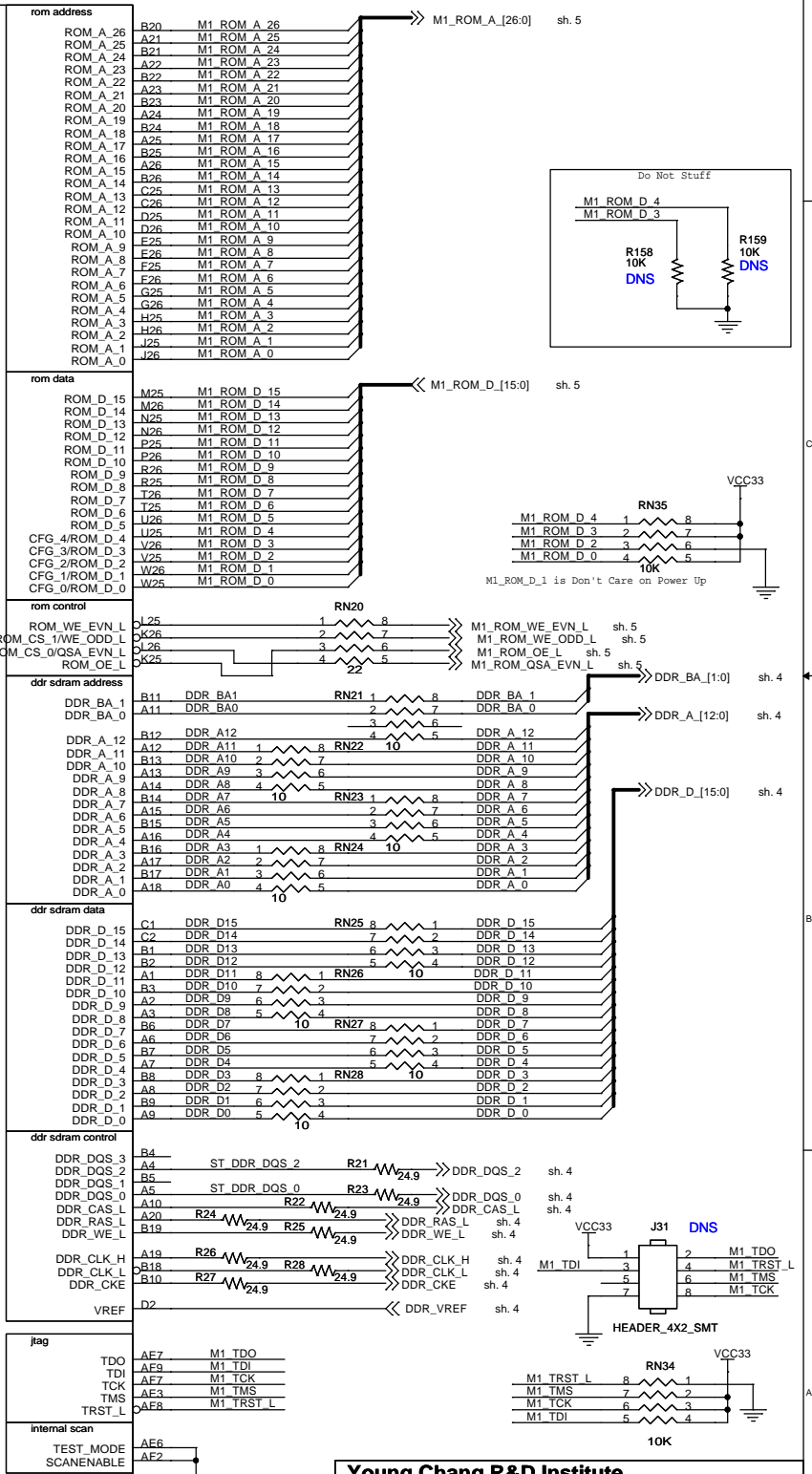
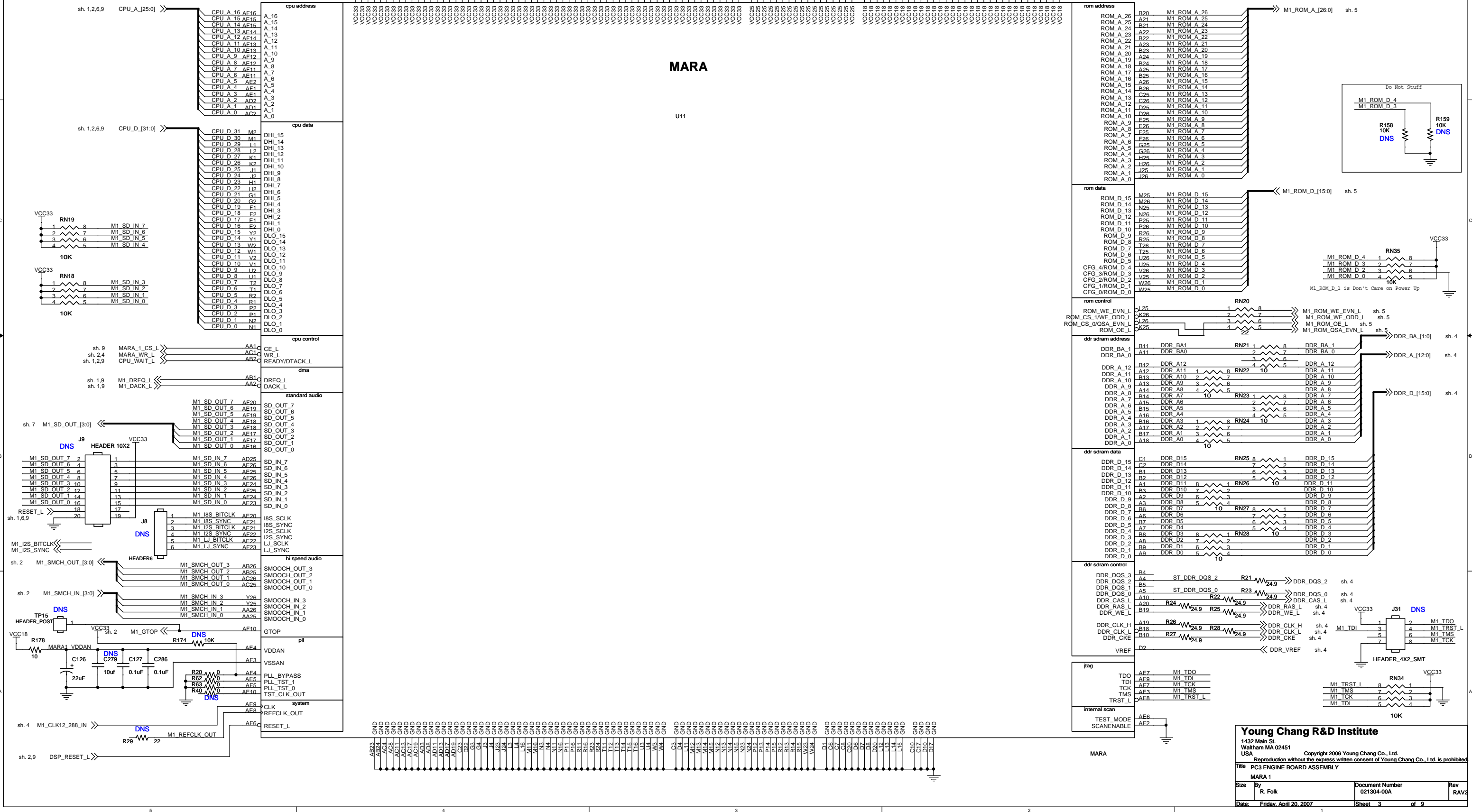

Young Chang R&D Institute
 1432 Main St.
 Waltham MA 02451
 USA
 Copyright 2006 Young Chang Co., Ltd.
 Reproduction without the express written consent of Young Chang Co., Ltd. is prohibited.

Title: **PC3 ENGINE BOARD ASSEMBLY**

MARA 1

Size	By	Document Number	Rev
	R. Folk	021304-00A	RAV2

Date: Friday, April 20, 2007 Sheet 3 of 9

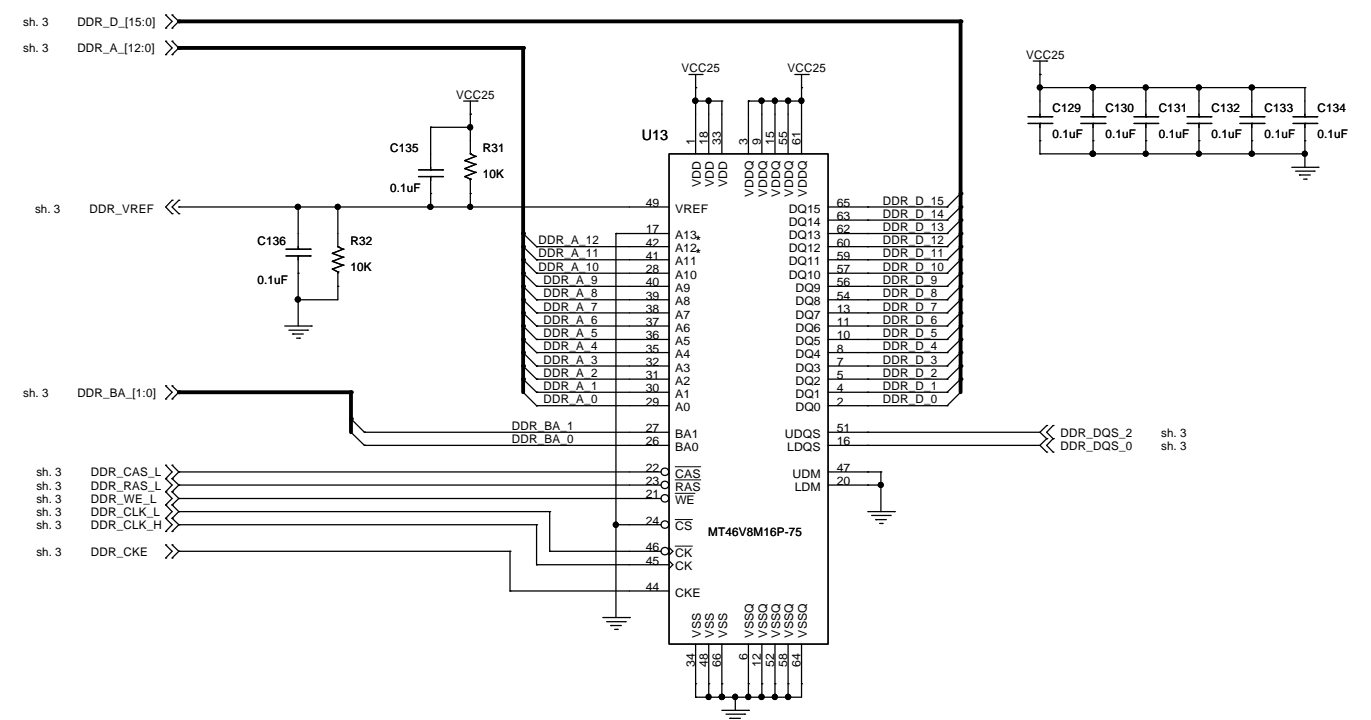
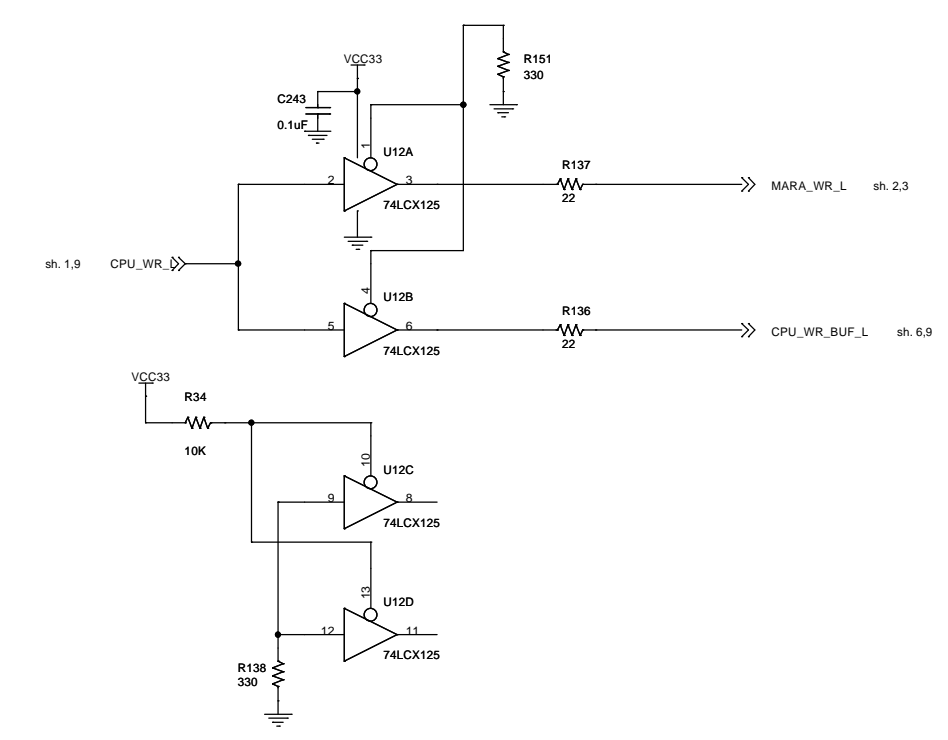
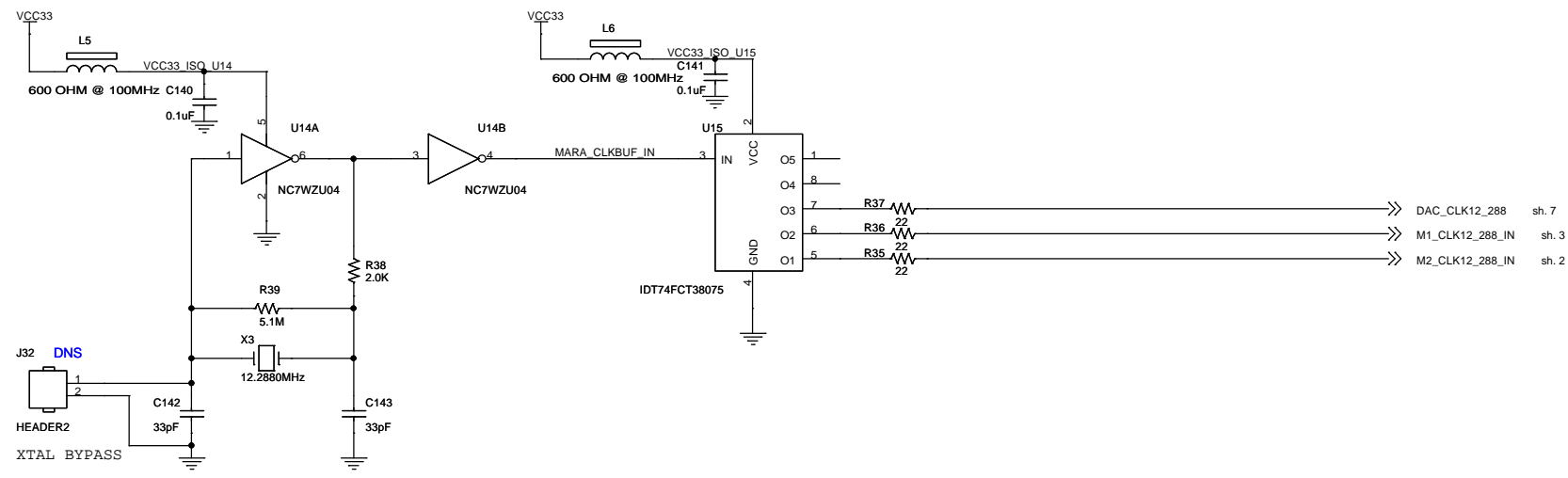

BUS EXCHANGERS

MASK ROM

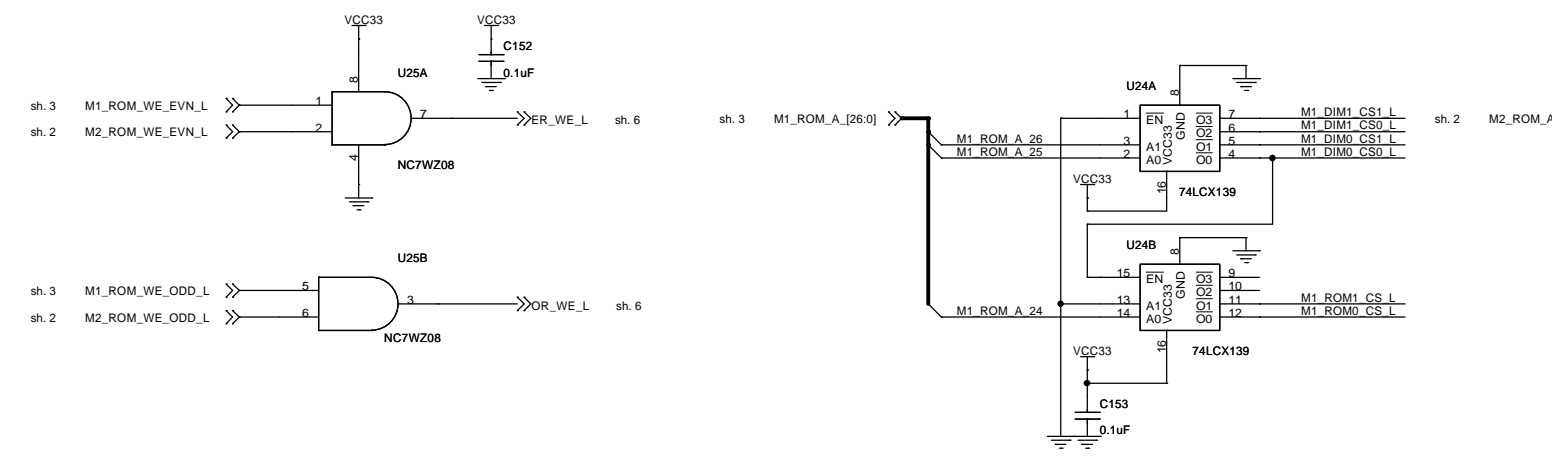
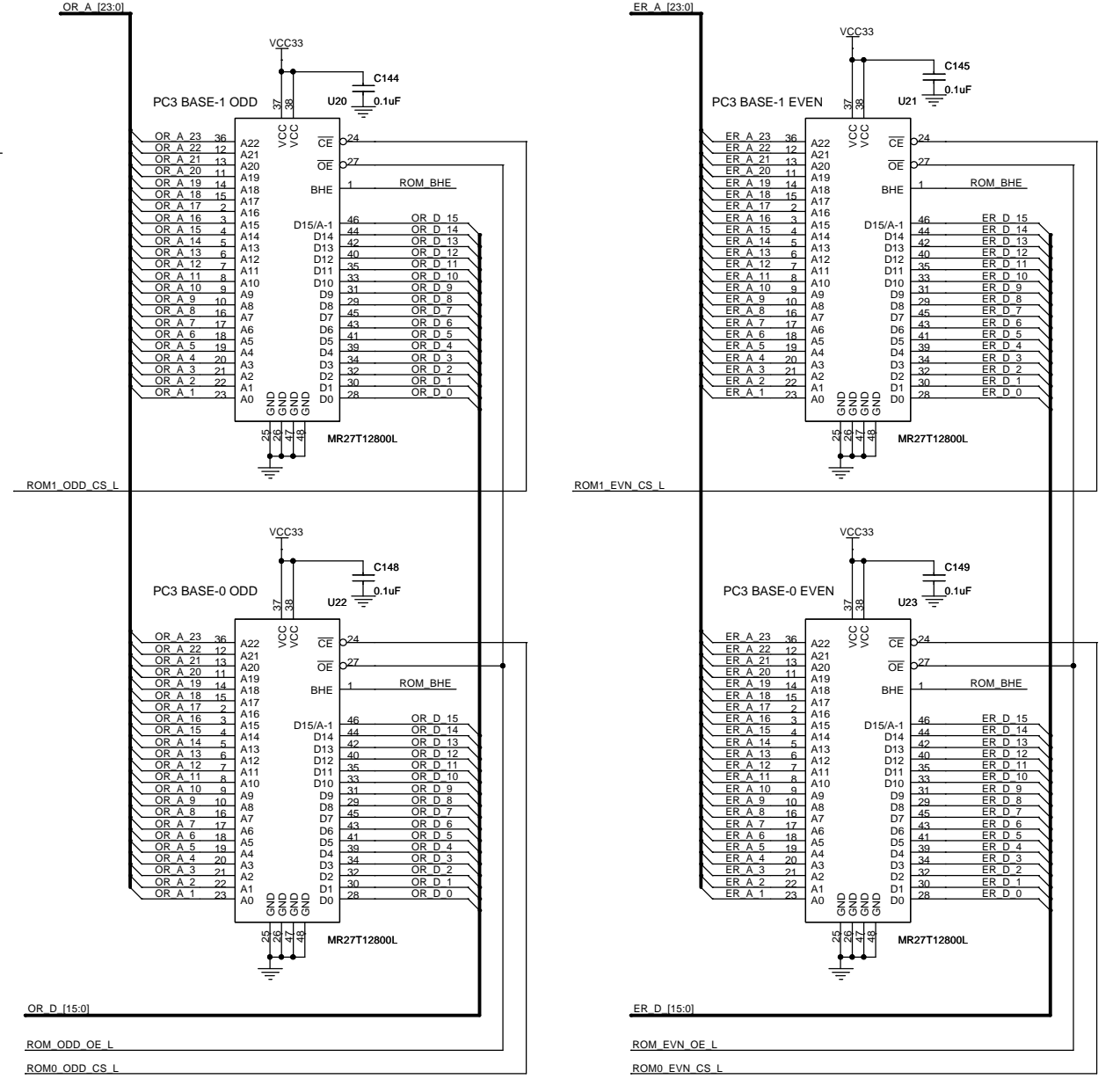
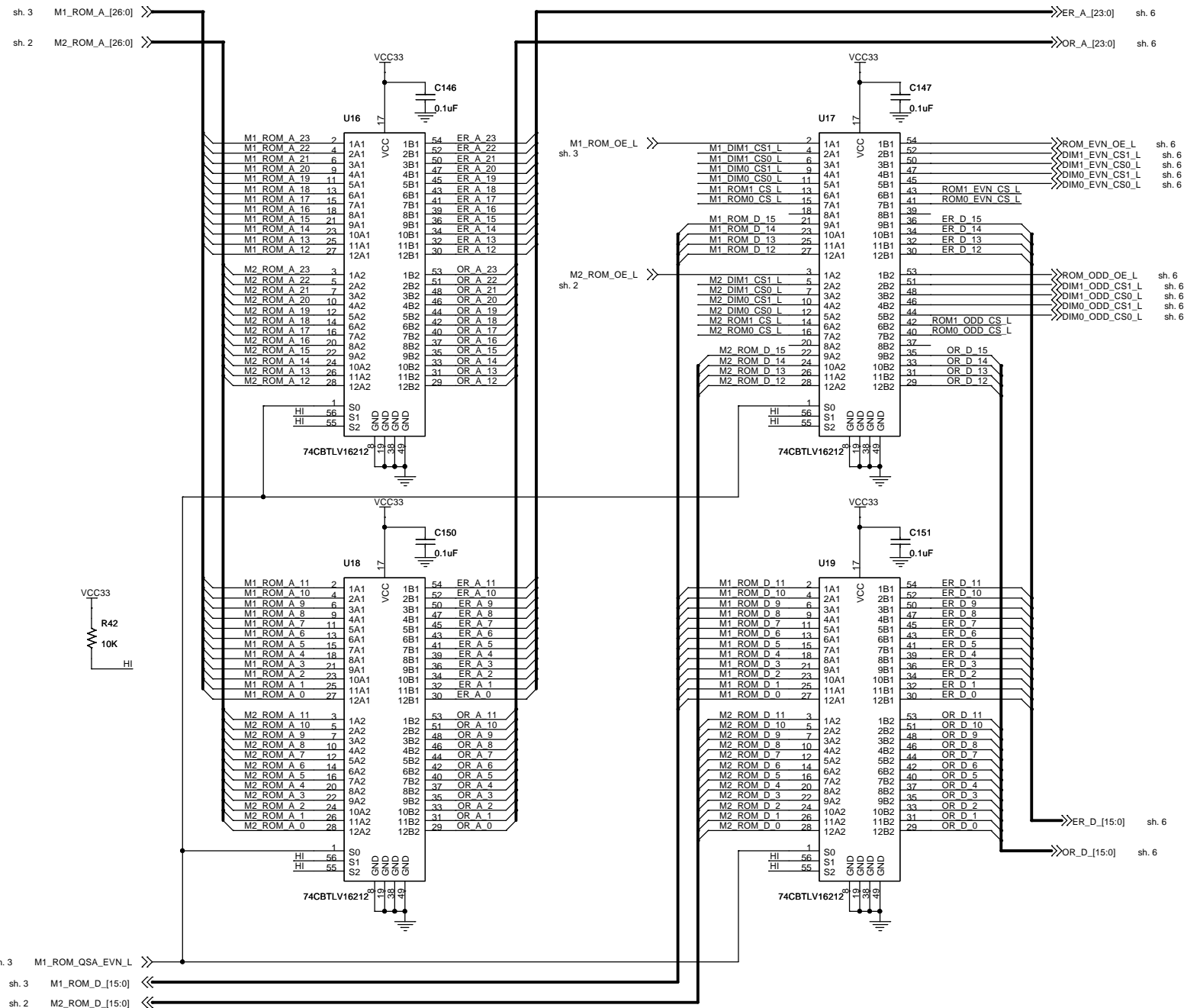

PC3 ROM DIMMS

SMARTMEDIA INTERFACE

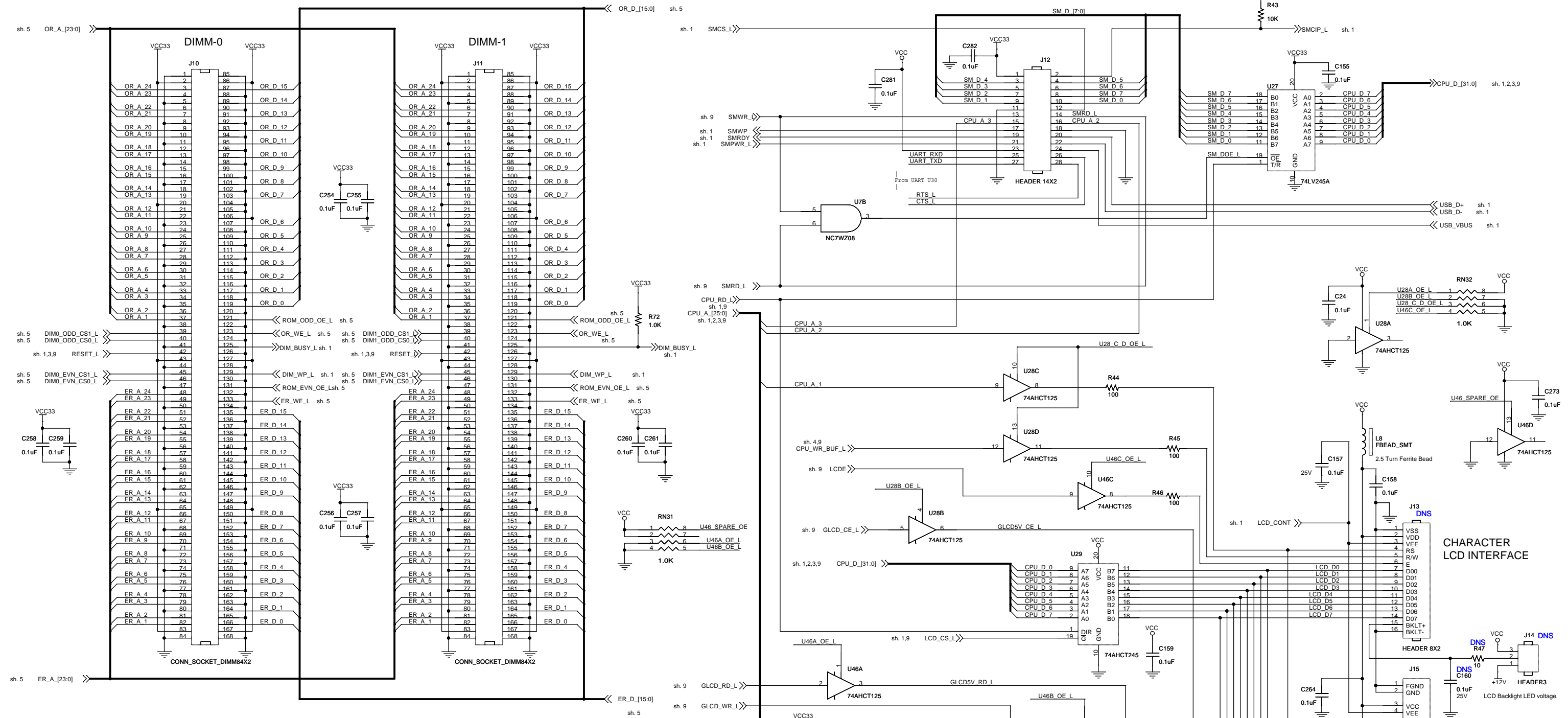

DEBUG RS-232 INTERFACE (NOT USED IN PRODUCTION)

