

PARTS MUST BE NEAR

CONNECTOR	COMPONENTS
J304	L2, R117, R20, RN6-8
J306	RN1-3
J307	RN4-5
J308	RN11, C1-3

Place D19-D22 between J306 and J307 near edge of board.

Add Silkscreen Text: "OPT 0" next to D19
 "OPT 1" next to D20
 "OPT 2" next to D21
 "OPT 3" next to D22

Also add this table in silkscreen on topside:

OPT 1	OPT 0
--	--
IN	IN
IN	IN
IN	IN

Young Chang R&D Institute
 1432 Main St.
 Waltham MA 02451
 USA

Copyright 2007 Young Chang Co., Ltd.
 Reproduction without the express written consent of Young Chang Co., Ltd. is prohibited.

Title: PC3 Connector Board
 M38869 Scanner

Size	By: H. Chamberlin	Document Number: 021221-002	Rev: A
Date: Friday, May 18, 2007	Sheet 1	of 4	

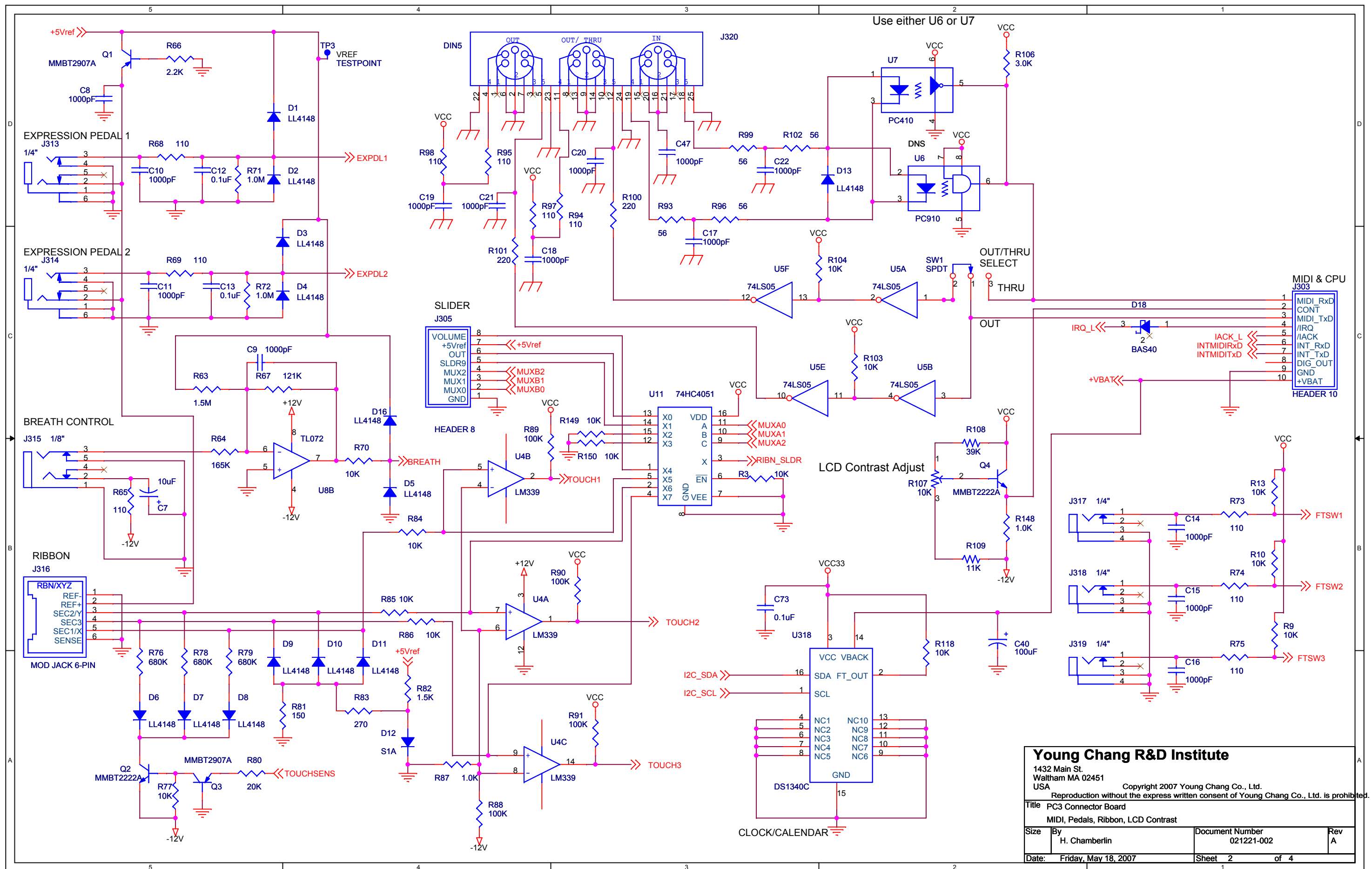

Young Chang R&D Institute
 1432 Main St.
 Waltham MA 02451
 USA

Copyright 2007 Young Chang Co., Ltd.
 Reproduction without the express written consent of Young Chang Co., Ltd. is prohibited.

Title: PC3 Connector Board
 MIDI, Pedals, Ribbon, LCD Contrast

Size	By: H. Chamberlin	Document Number: 021221-002	Rev: A
Date: Friday, May 18, 2007	Sheet: 2	of 4	

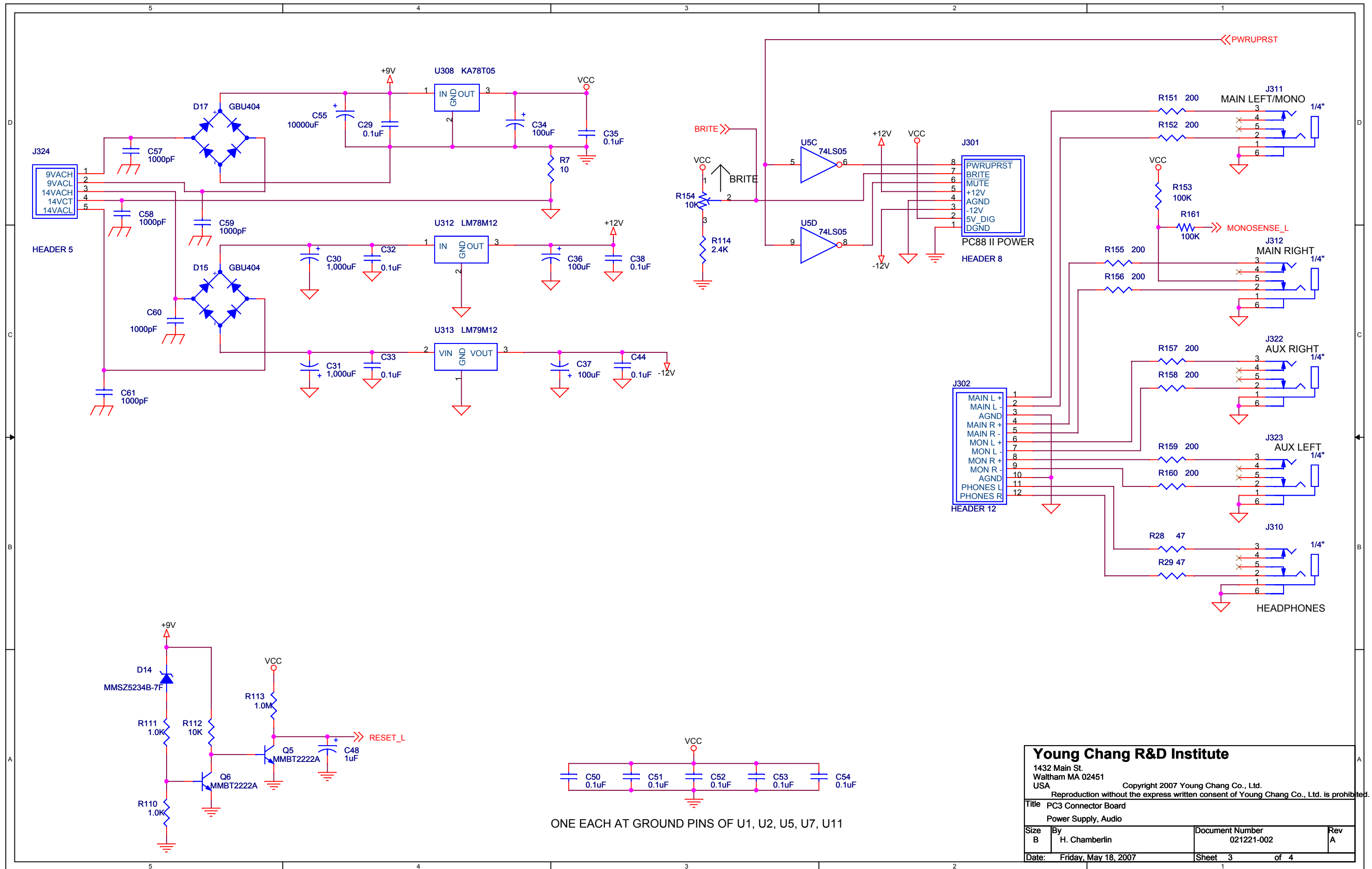

Young Chang R&D Institute
 1432 Main St.
 Waltham MA 02451
 USA
 Copyright 2007 Young Chang Co., Ltd.
 Reproduction without the express written consent of Young Chang Co., Ltd. is prohibited.

Title: PC3 Connector Board
 Power Supply, Audio

Size B	By H. Chamberlin	Document Number 021221-002	Rev A
Date: Friday, May 18, 2007	Sheet 3	of 4	

