

EQUIPMENT

Signal Generator - modulated 400 cps  
 Output Meter - 15 Ohms Impedance  
 Generator Series Capacitor - .1mF. Part No. 4006-005-03 for IFT alignment  
 - 8.2pF. Part No. 4008-012-01 for BROADCAST alignment.  
 IF Attenuator - Part No. 4121-014-01  
 Alignment Tools

- (a) Chisel Point Type: Part No. 4121-005-01 for trimmer capacitor adjustment
- (b) Flat Metal Blade Type: Part No. 4121-001-01 for IFT and Osc. shunt coil adjustment.
- (c) Tuning Unit Iron Core Adjustor: Part No. 4121-008-01
- (d) Alignment Gauge: Part No. 4121-023-02 for tuner 1000 Kc/s position.  
 Collector Current Meter Connection - Jack plug Part No. 7171-015-02.

CONDITIONS

NOTE. 1. Circuit board does not have to be removed from chassis for alignment purposes. If board is removed from its mounted position, the three lower screw contact pads must be connected to chassis for satisfactory operation.

NOTE. 2. All alignment operations are to be performed with the receiver functioning as a normal portable.

The receiver chassis has to be removed from can for alignment purposes.

1. Remove control knobs and unscrew knob from top of aerial. Do not push top rod downward after removing knob.
2. Remove two screws, escutcheon, "ON" indicator, dial reading and six inner screws from top of receiver.
3. Remove two screws, chrome base and eight inner screws from bottom of receiver.
4. Slide chassis out of cabinet. NOTE. It may be necessary to spring the lip of can beneath grille to provide adequate clearance for speaker gasket.
5. Remove speaker mount screws and disconnect clips from speaker terminals.

Volume Control - Maximum (fully clockwise)  
 Tone Control - Maximum treble (fully clockwise)  
 Output Level - 50 milliwatts, output meter reading with speaker voice coil disconnected.  
 Output Meter  
 Connection - To terminal clips on end of speaker leads  
 Supply Voltage -  
 and Connection - 9 Volt DC. — To plug on end of receiver battery leads.

INTERMEDIATE FREQUENCY TRANSFORMER ALIGNMENT

Turn tuning control until perm. tuner iron cores are out of the coil formers. Insert .1mF capacitor in series with generator "hot" lead.

Oper. No.	Generator Connection	Generator Frequency	Instructions
1.	To test pin "E" (term 4 of 2nd I. F. T.)	455 Kc/s	Adjust iron core of 4th IF trans. for max. output.
2.	As Oper. 1.	455 Kc/s	Adjust iron core of 3rd IF trans. for max. output.
3.	Repeat operations 1 & 2		
4.	To test pin "B"	455 Kc/s	Adjust iron core of 2nd IF trans. for max. output.
5.	To test pin "A" (mixer/osc base)	455 Kc/s	Adjust iron core of 1st IF trans. for max. output.

BROADCAST ALIGNMENT

If the receiver logging is satisfactory the signal circuits may be aligned as follows.

1. Connect IF attenuator to test pins "C" and "D" (resistor to pin "C").
2. Raise top rod of aerial approximately 1" above chassis then connect 8.2pF capacitor to rod.
3. To 8.2 pF series capacitor. 1000 Kc/s Tune receiver to generator frequency. Adjust RF. and both aerial trimmer capacitors for max. output.

BROADCAST ALIGNMENT

When iron cores or tuning unit coil assy. have been replaced or if station logging is outside limits.

Oper. No.	Generator Connection	Generator Frequency	Instructions
1.	Connect IF. attenuator to test pins "C" and "D" (resistor to pin "C").		
2.	Turn perm. tuner against high frequency end of travel stop. Set all iron cores so that not less than 3/8" of adjusting shafts protrude forward of front face of core carriage.		
3.	Raise top rode of aerial approx. 1". 1625 Kc/s Connect 8.2pF capacitor in series to rod.	1625 Kc/s	Adjust Osc. RF and both Aerial trimmer capacitors for max. output.
4.	Refer diagram. Place the 1000 Kc/s alignment gauge Part No. 4121-023-01 or alternatively a flat piece of metal 0.39" wide between the core carriage and loose collar. Gently turn tuning spindle until gauge is located squarely between collar and carriage.		
5.	As oper. 3.	1000 Kc/s	With tuner set in position detailed, adjust Osc. , RF, and both Aerial iron cores for maximum output.
6.	As oper. 3.	600 Kc/s	Rock tuning control through signal, adjust Osc. shunt coil iron core for max. output.
7.	Turn tuning control to low freq. end of travel (iron cores full in). Tune signal generator to receiver. The low freq. tuning limit should be between 510 and 528 Kc/s.		
8.	Repeat operations 4 and 5.		
9.	Align dial pointer.		

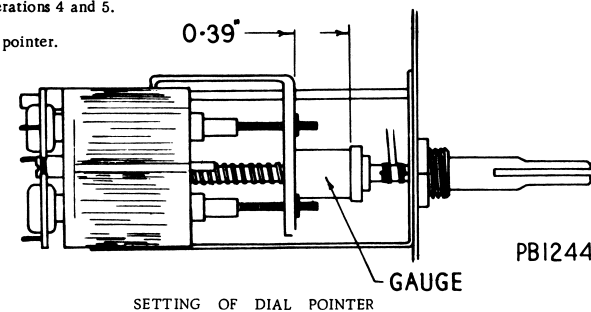

SETTING OF DIAL POINTER

PB1244

Disconnect the IF attenuator.

Disconnect 8.2pF series capacitor and raise rod aerial to full extent. Accurately tune receiver to a station marked on dial near 1000 Kc/s. Slip dial pointer carriage assy. along guide rail until the centre of the pointer coincides with centre of the tuned station call sign. Check dial logging and if necessary readjust pointer carriage.

AERIAL MATCHING CONTROL ADJUSTMENT - Gutter Mount Aerial.

Connect plug on end of lead from gutter mount aerial to socket on side of receiver can. Push in-built telescopic aerial downward into receiver.

Remove chrome base from receiver and move battery out of battery box. Tune receiver to a weak station near 1000 Kc/s (approx. center of dial). Adjust trimmer (screw driver slot in battery box), for maximum output.

AERIAL MATCHING CONTROL ADJUSTMENT - Cowl Mount or Fully Retractable Aerial.

With receiver operating as a car radio, raise aerial to half extended height and tuned to a weak station near 1000 Kc/s (approx. center of dial). Adjust knob on passenger side of panel housing (cradle) for maximum output.

2N406

2N591

2-AC128

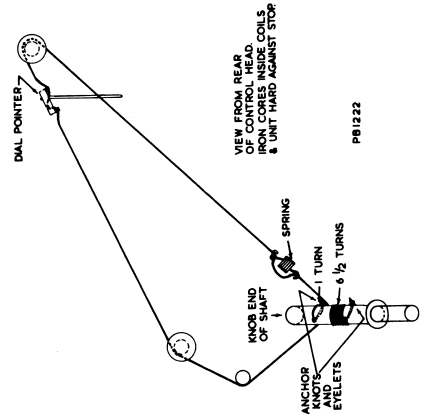
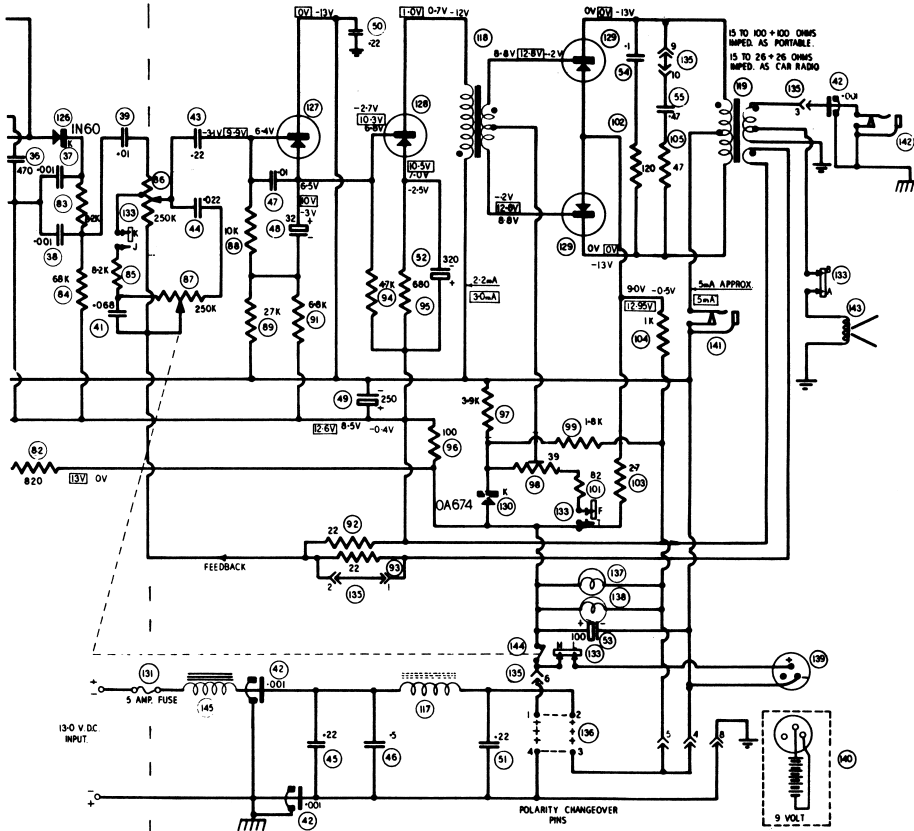

PB1222

A82.a

# ASTOR MODEL P4C

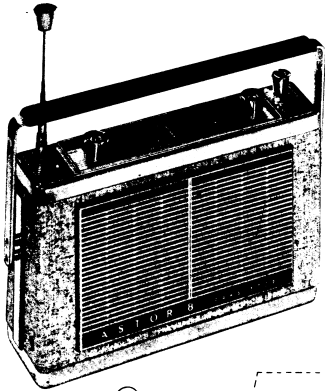

AT17

2N412

2N410-E

2N410-B

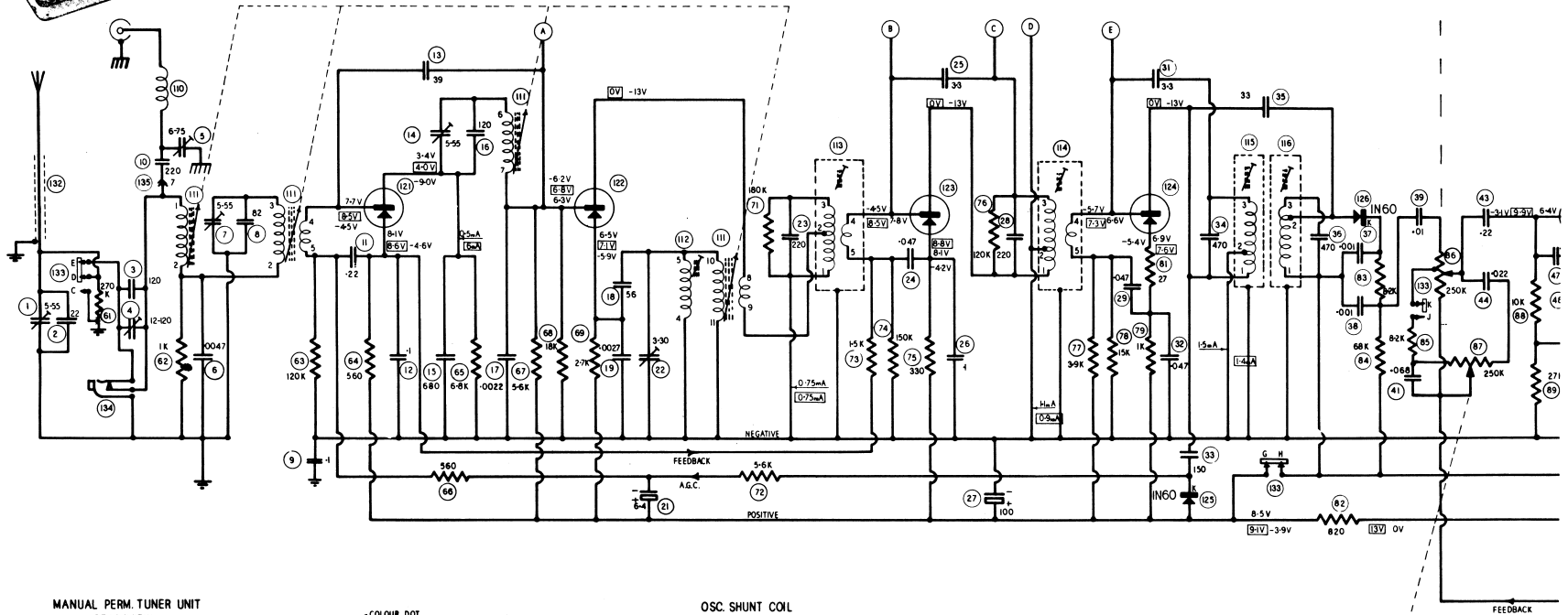

MANUAL PERM. TUNER UNIT  
REAR VIEW

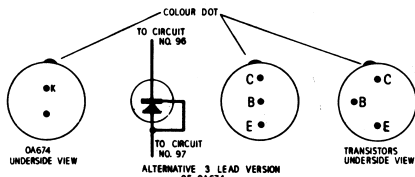
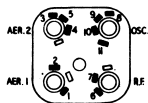

1N60 DIODE

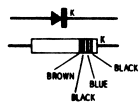

OSC. SHUNT COIL & I.F. TRANSFORMER  
UNDERSIDE VIEW

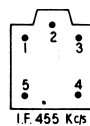

NUMBERS ASSIGNED TO TERMINALS OF COILS AND TRANSFORMERS ARE TO FACILITATE CIRCUIT TRACING OR COMPONENT REPLACEMENT AND MAY NOT BE FOUND ON THE UNIT.  
IMPORTANT: REFER TO SERVICE DATA P4C-1 FOR INSTRUCTIONS BEFORE ADJUSTING COLLECTOR CURRENT OF AC12B'S.  
WARNING: POLARITY PLUG MUST BE CORRECTLY INSERTED ONTO POLARITY PINS BEFORE CRADLE IS CONNECTED TO BATTERY.

## MODEL P4C

MANUAL TUNING  
9 VOLT PORTABLE OPERATION.  
12 VOLT POSITIVE OR NEGATIVE TO CHASSIS  
CAR RADIO OPERATION.

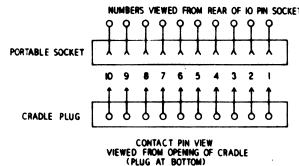

CHANGE-OVER SWITCH (SHOWN IN PORTABLE POS)

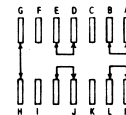

SPRING END OF SWITCH

NOTE:

- ⬇ DENOTES PORTABLE GROUND
- ⬆ DENOTES CRADLE GROUND
- ⬆ DENOTES PLUG & SOCKET CONNECTIONS
- DENOTES TEST PINS.

