

INSTRUCTION MANUAL

for the

NATIONAL MODEL

NC-33 RECEIVER

SECTION 1. INSTALLATION

1-1. Installation Procedure

The NC-33 Receiver is designed to operate from a 105/130 volt, 50/60 cycle, A.C. source of supply or a 105/130 volt, D.C. source of supply. Normal power consumption is approximately 24 watts at 115 volts.

Installation of the NC-33 is accomplished as follows:

1. Connect the antenna, as recommended in Section 1-2.

2. Connect a good external ground (radiator or water pipe) to the terminal labeled G on the antenna terminal strip at the rear of the Receiver. This connection, if used, serves two purposes:

a. Achieves a considerable reduction in noise interference in certain localities.

b. Eliminates the possibility of shock occurring if the operator makes bodily contact between the Receiver and ground.

3. Connect the power cable and plug to the proper source of supply i.e., 105/130 volts, 50/60 cycles, A.C. or 105/130

volts, D.C. Proper polarity of the plug should be observed when connection is made to a power source, although no damage to the Receiver will occur if the polarity is reversed. Reversed polarity will be evidenced as follows and is corrected by simply reversing the plug prongs in the power outlet.

a. D.C. Power Source--The Receiver will be inoperative, although the tubes and pilot lamp will light.

b. A.C. Power Source--A hum may be heard in the output of the Receiver.

Proper polarization of the plug will eliminate the possibility of shock occurring in installations where one side of the power line is grounded, if the operator should make bodily contact between the Receiver and ground.

4. Adjust controls as recommended in Section 2 for the reception of signals.

1-2. Antenna Recommendations

The antenna input circuit of the NC-33 is arranged for operation from either a single-wire type, doublet type or other types of antennas having impedances of 70

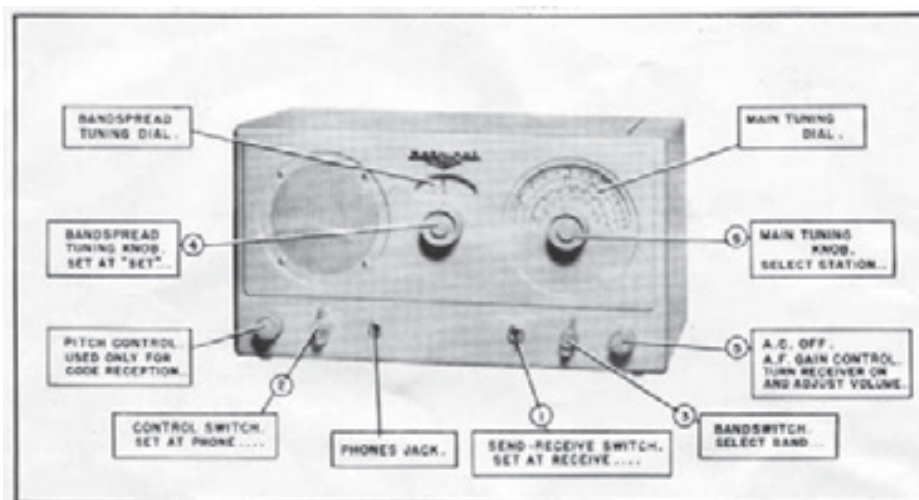

Figure No. 2. Simplified Operating Instructions

ohms or more. The input impedance of the antenna circuit is approximately 300 ohms.

The most practical antenna for use in installations where the Receiver is to be used over a wide range of frequencies is the single-wire type. An antenna length of from 50 to 75 feet is recommended, although the length is not critical and any length from 25 to 75 feet may be used. If the Receiver is to be operated on one frequency or narrow band of frequencies, best results will be obtained by the use of a tuned antenna, such as the folded doublet or half-wave dipole type, designed for the operating frequency.

The methods of connecting the various

types of antennas to the antenna terminal strip at the rear of the Receiver are as follows:

1. Single-wire type--Connect the antenna to terminal A at the left of the strip, and connect the metal link to the unused A terminal.
2. Doublet-Type--Connect the antenna feeders to the two terminals marked A; the metal link is not used.
3. Concentric transmission line type--Connect the inner conductor to terminal A at the left of the strip and the outer conductor to the other A terminal. Connect the metal link to the center A terminal.

SECTION 2. OPERATION

2-1. General Description

The NC-33 is an A.C./D.C. superheterodyne Receiver having a complement of five tubes plus a rectifier, with a continuous frequency range of from 500 kilocycles to 35 megacycles. The Receiver is designed to provide reception of amplitude modulated voice or music and code telegraphy signals throughout its entire frequency range.

A stage outline of the circuit employed in the Receiver is given below, together with the tube type associated with each stage.

Converter.....	12SA7
I.F. Amplifier (455 Kc.).....	12SG7
Second Det.-A.V.C.-A.N.L.....	12H6
First Audio-C.W.O.....	12SL7GT/G
Audio Output.....	35L6GT/G
Rectifier.....	35Z5GT/G

Two audio output circuits are provided in the NC-33:

1. The loud-speaker is a 5 inch P.M. type.
2. A Phones jack is mounted on the front panel and is wired so as to silence the loud-speaker when headphones are used. The headphone load impedance is not critical, permitting the use of a wide range of headphone types, including crystal types.

2-2. Tuning System

The two-gang main tuning capacitor, the two-gang bandspread capacitor and four sets of coils are used to cover the frequency range of the NC-33 in four tuning bands as shown on the following table. The main tuning and bandspread tuning capacitors are connected in parallel on all bands.

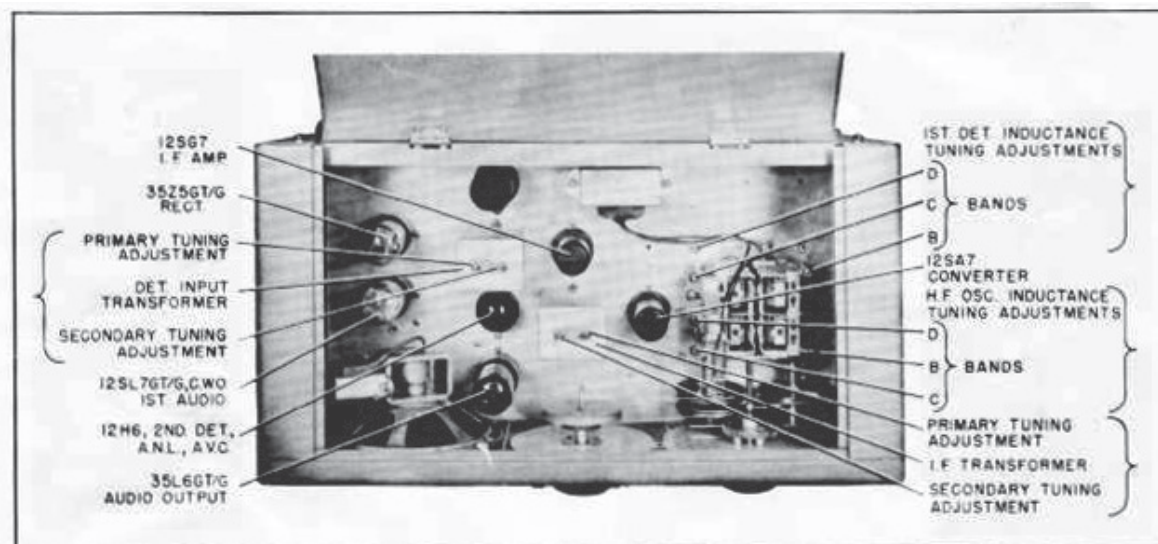

Figure No. 1. Tube and Alignment Adjustment Locations

BAND	FREQUENCY COVERAGE
A	12.0 - 35.0 Mc.
B	4.0 - 12.0 Mc.
C	1.42 - 4.2 Mc.
D	0.5 - 1.42 Mc.

The main dial has four scales accurately calibrated directly in megacycles. The respective scales are marked with heavy black scorings to clearly locate for the operator such short-wave features as the Amateur, Police and Foreign Broadcast bands. These locating markers are identified by letters AM, P and F, respectively.

2-3. Operating Instructions

After the NC-33 has been installed as outlined in Section 1, it is placed in operation for voice or music reception by adjustment of the receiver controls. Figure No. 2 gives the step-by-step procedure to follow for the reception of signals. The same procedure is outlined below with a brief description of the function of each control.

1. Set the SEND-RECEIVE switch at Receive. This switch, in the Send position, is used to quiet the Receiver for a period of time, such as during a transmitting period, when it is desirable to resume reception immediately without waiting for the tubes to warm up. The function of the SEND-RECEIVE switch may be duplicated at an external (remote) position by connecting a switch or relay contacts to the B. Sw. plug at the rear of the NC-33. This is a parallel arrangement permitting the use of the panel-mounted SEND-RECEIVE switch to turn the Receiver on, although the external switch is at off.

2. Set the control switch at Phone. The control switch has three functions corresponding to the switch markings, C.W., Phone and A.N.L. The Phone position is normally used for all reception except that of code telegraphy signals. The two settings, Hi and Lo, of the Phone position provide a selection of tonal output. In the Hi position normal receiver reproduction is heard. In the Lo position the higher frequency tones are subdued and the audio response is rich in lower tones. The A.N.L. position is used to effectively reduce interference such as might be caused by static or automobile ignition noise. The automatic volume control circuit is operative in both the Phone and A.N.L. positions. The C.W. position of the control switch renders the automatic volume control circuit inoperative and switches the C.W.

oscillator into the circuit to permit the reception of code telegraphy signals.

3. Set the band switch at the band of frequencies to be tuned. The four positions of the band switch select the proper set of coils to cover the frequency range of the four tuning bands of the NC-33. Each position is marked with a band letter designation which corresponds to the markings appearing on the main dial.

4. Set the bandspread dial pointer at the Set mark. The bandspread control knob and dial scale are used for bandspread (fine) tuning and logging. Bandspread tuning is accomplished by spreading out over a wide range any small portion of the frequency range of the Receiver. To do this, set the main tuning dial pointer at the high-frequency limit of the band of frequencies to be spread, and tune to the desired signal by rotating the bandspread tuning knob in a clockwise direction.

5. Turn the A.F. GAIN control from the A.C. Off position to the point providing the desired audio volume. In the A.C. Off position the NC-33 is turned off; advancing the control knob in a clockwise direction turns on the Receiver and increases the audio output volume to a maximum at the extreme clockwise position.

6. Set the main tuning dial pointer at the desired frequency. The main tuning control knob and dial scale are used to tune the entire frequency range of the Receiver, and tunes at any one time the band of frequencies selected by the band switch. To maintain correct calibration, when using the main tuning knob, the bandspread dial pointer must be at the Set mark. It should be noted that the image signal on the B, C and D bands appears 910 kilocycles lower on the dial than the fundamental signal, while on the A band the image is 910 kilocycles higher on the dial.

2-4. Code Telegraphy Reception

The adjustment of the receiver controls for code reception is the same as that for voice and music except as follows:

1. Set the control switch at C.W.
2. Adjust the PITCH control to secure an audio tone pleasing to copy. This control is operative only when the control switch is at the C.W. position. The C.W. oscillator is tuned to the receiver's intermediate frequency at approximately mid-scale on the control knob. The range of the PITCH control is approximately 3,000 cycles.

This equipment is warranted to be free from defective material and workmanship and repair or replacement will be made of any part which under normal installation, use and service discloses defect, provided the unit is delivered by the owner to the manufacturer or through the authorized radio dealer or wholesaler from whom purchased, intact, for examination, with all transportation charges prepaid to the factory, within sixty days from the date of original shipment from the factory, and provided that such examination discloses to the manufacturer's judgment that it is thus defective.

This warranty does not extend to any radio product which have been subjected to misuse, neglect, accident, incorrect wiring, improper installation, or to use in violation of instructions furnished by the manufacturer, nor extend to units which have been repaired or altered outside of the factory, nor to cases where the serial number thereon has been removed, defaced or changed, nor to accessories used therewith of other manufacture.

Any part of a unit approved for remedy or exchange hereunder will be remedied or exchanged by the authorized radio dealer or wholesaler without charge to the owner.

This warranty is in lieu of all other warranties expressed or implied and no representative or person is authorized to assume for the manufacturer any other liability in connection with the sale of their radio products.

National Company, Inc. reserves the right to make any change in design or to make addition to, or improvements in, its products without imposing any obligations upon itself to install them in its products previously manufactured.

NATIONAL COMPANY INC. — MALDEN, MASS.

SM-400-440—ER.224

PRINTED IN U.S.A.

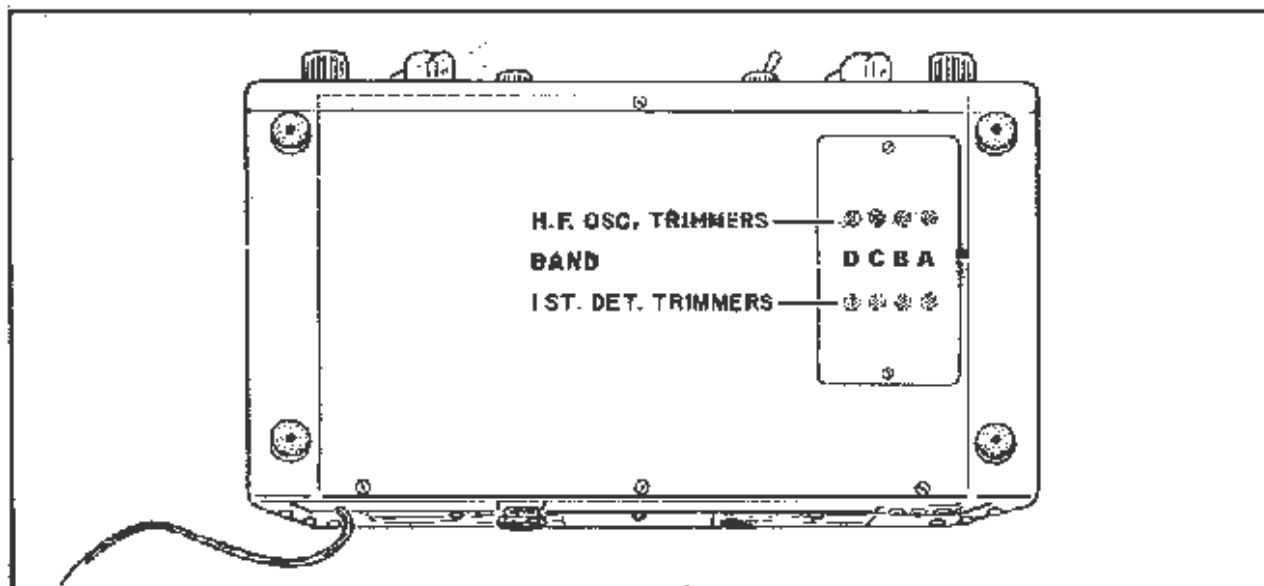

Figure No. 4. R.F. Alignment Trimmer Locations

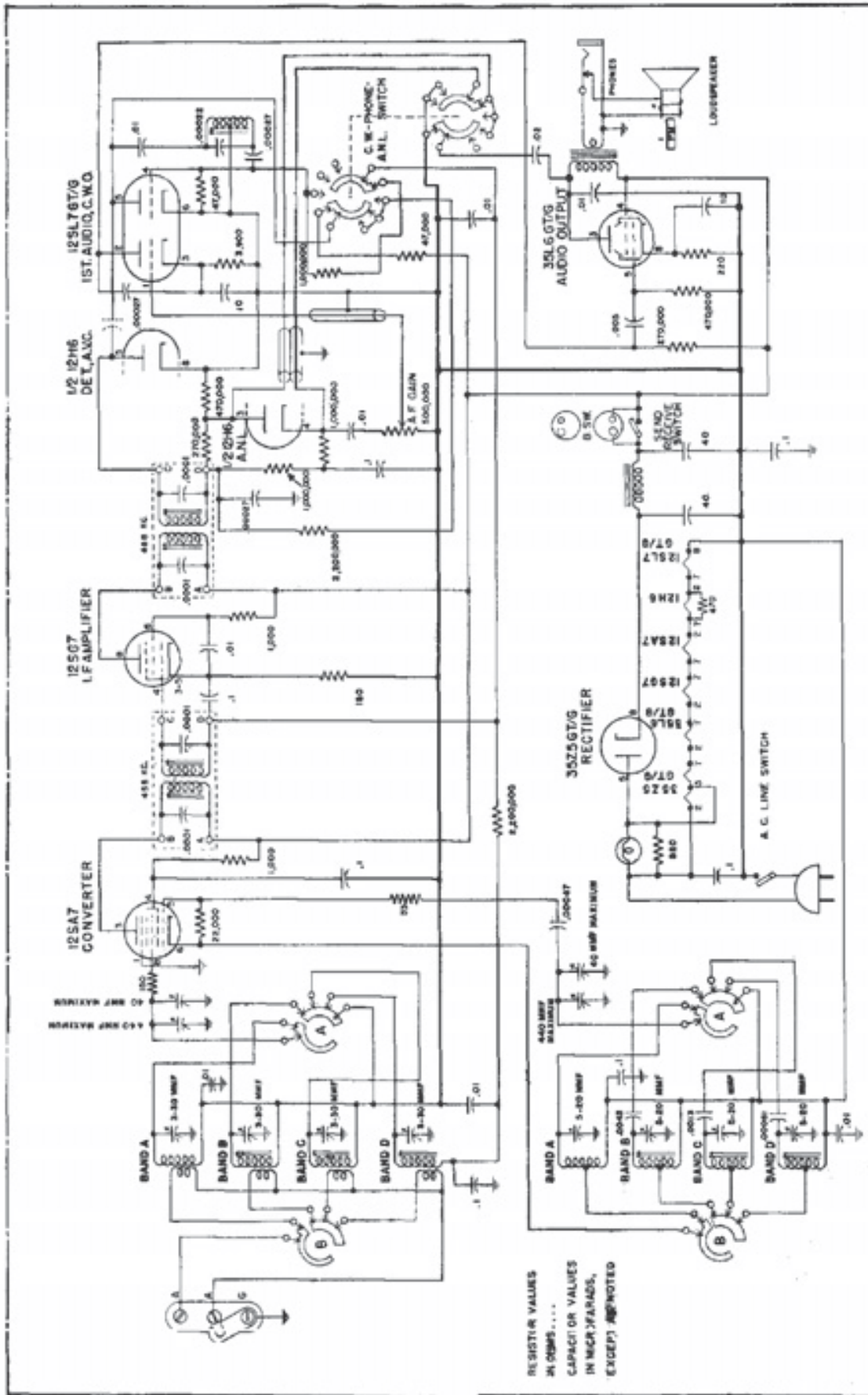

Figure No. 3. Schematic Diagram - NC-13 Receiver

