

INSTALLATION AND OPERATING INSTRUCTIONS

ON

NATIONAL "FB-7"

TUBES. Seven tubes are required for the "FB-7" receiver, exclusive of the power pack, as follows:

1st Detector	57	2nd Detector	56
High Frequency Oscillator	224 or 24A	Beat Oscillator	224 or 24A
1st Intermediate	58	Output Amplifier	59
2nd Intermediate	58		

The positions of the various tubes are shown in the attached plan of the receiver.

It is understood that in order to secure best results, tubes of recognized quality and average characteristics should be employed.

POWER SUPPLY. The special NATIONAL Type No. 5887-AB power pack is recommended for obtaining the best results where not more than $1\frac{1}{2}$ watts of audio power is necessary. This unit supplies 180 volts maximum at full load and $2\frac{1}{2}$ volts at $9\frac{1}{2}$ amperes to the heaters. All voltage dividers, etc., are built into the receiver.

If more audio power is required, the NATIONAL Type No. 5897-AB unit should be employed. This supplies approximately 240 volts at full load.

Both power packs employ the 280 rectifier tube. The use of mercury vapor tubes is not recommended.

If desired, the "FB-7" may be operated from a suitable filament transformer with 180 volts of B-battery. The total current drain at this voltage is approximately 40 m. a., and varies somewhat with the setting of the volume control.

ANTENNA. Antenna dimensions are not at all critical, but some experimentation is advised in order to determine the length of wire giving the best performance. If, for instance, local noise level or static is particularly high, a short wire will probably be preferable.

Referring to the circuit diagram, it will be seen that the antenna circuit consists of a primary coil and a series condenser. This arrangement is used to eliminate antenna tuning effects due to capacity or inductive loading.

Special antennas, such as the doubler and various forms of resonant antennas that are normally employed without a ground, may be connected to the antenna and ground terminals provided the ground post is disconnected from the chassis. This may be done very easily since an insulated mounting is employed.

OUTPUT CIRCUIT. The plate circuit of the output tube is brought to the output tip jacks located at the rear right-hand corner.

When using the 180 volt supply, the plate current of the 59 tube is less than 20 m. a., which will not appreciably affect the performance of any properly designed magnetic speaker. Certain types, however, such as the inductor dynamic, require a filter system, which may consist of a 1 to 1 transformer or a 30 henry choke, and a 1. mfd. condenser. The permanent magnet dynamic speakers will give excellent results and their use is recommended.

A headphone jack for connecting the phones in the plate circuit of the second detector, is located at the rear left corner. Inserting the phone plug automatically disconnects the grid circuit of the 59 tube, the plate circuit remaining unchanged.

CONTROLS. The middle knob is the main tuning control, operating the ganged high frequency oscillator and first detector tuning condensers. Frequency increases with dial reading.

The left-hand toggle switch opens the main B supply circuit, leaving the heaters lighted, and is particularly useful for turning off the receiver during transmission periods. If B battery plate supply is employed, the switch should be thrown to the "Off" position at all times when the receiver is not in use.

The right-hand toggle switch controls the beat oscillator, which is coupled to the input circuit of the second detector and is used primarily for the reception of c. w. signals, although it is helpful in locating weak phone carriers.

Beat oscillator tuning may be adjusted by means of either of the adjustment screws located at the top of the oscillator coil shield, mounted between the 56 and the 224 tubes. Normally, the oscillator is adjusted to the frequency of the intermediate amplifier, as determined by the pitch of the background hiss. Improved selectivity may be obtained by detuning the oscillator from the i. f. by approximately 1000 cycles. Such detuning will emphasize one side of the carrier beat.

The knurled disc below the tuning knob is the volume control, calibrated in steps of approximately 8 db. from 1 to 9. The signal which is just audible with the control full on, that is, at 1, will be R-1 on the audibility scale; a signal which is just audible with the control set at 8, will be R-8, etc.

INTERMEDIATE FREQUENCY AMPLIFIER. The i. f. amplifier is tuned to a frequency of approximately 485 k. c., tuning being accomplished by means of the condenser adjusting screws located at the top of the intermediate frequency transformer shields.

COIL AND TRIMMER ADJUSTMENT. A parallel padding, or range adjusting, condenser is mounted inside each of the oscillator coils, and may be set with a screw driver inserted in the hole just below the coil handle. When properly adjusted, the tuning will check the calibration curves closely. Tightening the screw will give higher dial readings.

The detector coils for full coverage (1500-20,000 k. c.) are trimmed by a condenser mounted between the gang tuning condenser and the detector tube. This condenser also serves as an antenna compensator for these coils only.

Individual trimmer condensers are mounted inside each band-spread coil, so that the r. f. and detector stages may be brought into exact alignment with the band properly centered on the dial. The high frequency edge of all the bands is at 120 and the low frequency edge at 20.

The setting of these trimmer condensers, particularly those of the oscillator coils is quite critical. If it is found necessary to readjust any of them, it will be noticed that the frequency will creep for a few seconds after the adjustment is made, particularly on the two higher frequency bands.

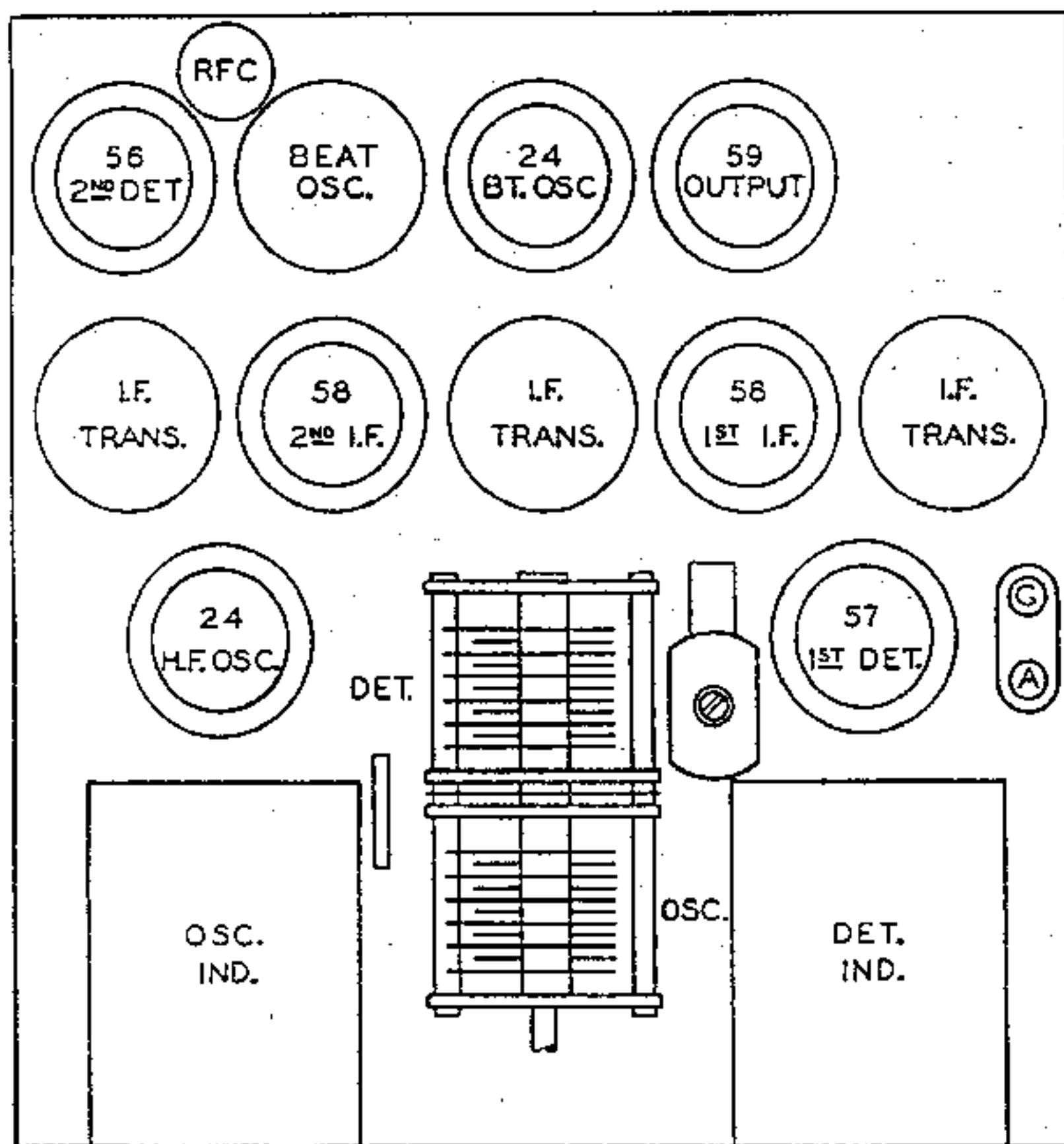

Tube Locations — Plan

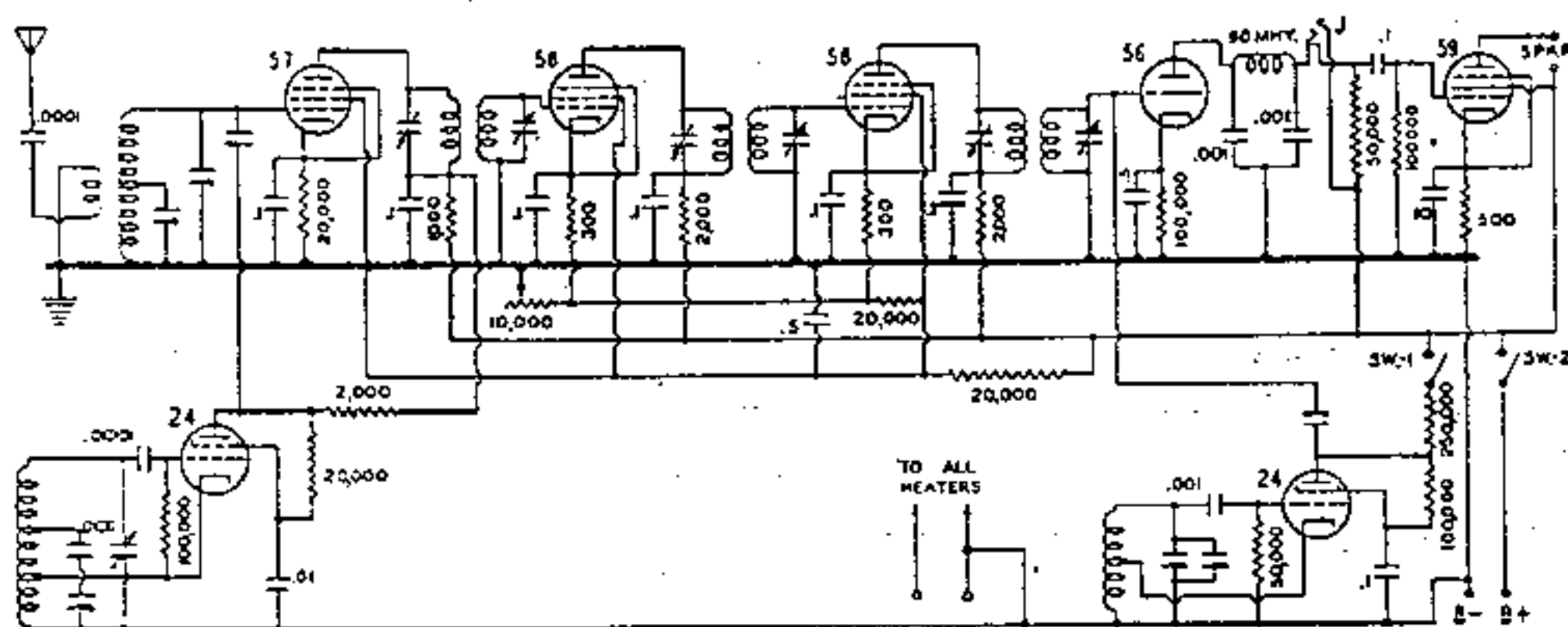

Circuit Diagram of F-B 7

SPECIAL INSTRUCTIONS

FOR

NATIONAL FBX RECEIVERS

The FBX receiver employs essentially the same circuit as that of the FB-7 but, in addition, has a quartz filter connected at the input of the I. F. amplifier. The crystal, its associated I. F. transformer, selectivity control, selector switch and phasing condenser, are mounted in the rectangular compartment at the right-hand side of the chassis.

The knob at the side of the cabinet is the crystal selector switch and has three positions: the middle position connects the crystal in series for single signal reception; the left-hand position (rotating counter-clockwise) connects the crystal in parallel; while the right-hand position removes it from the circuit.

The knurled bakelite disc, the edge of which protrudes through a slot at the upper right-hand side of the cabinet, is the selectivity control. When the crystal is not being used, this control should be adjusted for maximum signal strength, since it acts merely to tune the intermediate transformer secondary. When the series connection is employed (central switch position) the same setting of the selectivity control which gave maximum response in the first case, will now give minimum selectivity. As the control is turned in a counter-clockwise direction: that is the outside of the disc moved toward the back of the set; the selectivity will be improved until the maximum point is reached.

When the crystal is connected in parallel for rejecting an unwanted carrier, the selectivity control should be adjusted to give maximum I. F. response, since in this case the action of the selectivity control is simply to tune the I. F. transformer secondary. When using the parallel connection, the setting of the tuning condenser that eliminates the undesired signal is just as critical as that giving peak response in the case of the series connection.

A trimmer adjusting screw will be found near the centre at the top of the crystal filter compartment. This is the phasing, or crystal balancing condenser, the correct adjustment of which is explained in the last paragraph.

For best results, it is of course, necessary that the whole I. F. amplifier be tuned exactly to the crystal frequency. The tuning may be very easily checked at any time by throwing the crystal selector switch to the series position and, after a steady signal has been tuned in, checking the adjustment of each I. F. tuning condenser for maximum response. The primary of the crystal filter input transformer is not tuned.

It is advisable to check the alignment of the circuits occasionally, especially where wide variations in room temperature are prevalent.

The operation of the FBX receiver when the crystal selector switch is in the "Off" position, is the same as that of the FB-7 and needs no further comment.

When the series connection is employed for phone reception, it will probably be found advisable to set the selectivity control at that point giving minimum selectivity, in order to avoid excessive side hand cutting.

For single signal c. w. reception, the selectivity control should be set at the point giving maximum selectivity, as evidenced by the fact that static, circuit noises, etc., all have the same characteristic ring or pitch, determined by the adjustment of the beat frequency oscillator. Under these conditions, as the receiver is tuned slowly across a carrier, the audio response will be sharply peaked at the "characteristic pitch," all other points being extremely weak in comparison.

The beat oscillator may be adjusted to suit the individual preference of the operator, by means of the knob mounted on top of the oscillator coil shield.

Should the operator wish to check the adjustment of the phasing condenser, the simplest method is as follows: with the crystal connected for series operation and the selectivity control adjusted for maximum selectivity, tune in a stable signal, preferably from a local oscillator; find the peak response; tune to the other side of the audio image where the signal will be very weak, and adjust the phasing condenser for minimum response.

DETAILED ALIGNMENT INSTRUCTIONS

FOR

FB-7 — FB-X

All FB-7 and FB-X receivers are thoroughly and carefully aligned at the factory and, as a general rule, it is not necessary to make readjustments. It is strongly recommended, therefore, that all adjustments be left in the original positions except in such cases where they are obviously wrong.

When all adjustments are correct, the receiver will, of course, operate at its best; that is, with maximum selectivity and minimum image frequency reception. In any superheterodyne, however, especially those not having pre-selection before the first detector, images and repeat points are to be expected to some extent, and while such interference may be reduced by proper adjustment of the detector coil as outlined below, their presence does not necessarily indicate incorrect adjustment.

The amateur band spread coils for the FB-7 and FB-X receivers are adjusted by means of a suitable monitor or frequency meter. The position of the band on the dial is determined entirely by the adjustment of the oscillator coil padding condenser, which is mounted inside the oscillator coil and which may be adjusted by means of a screw driver through the hole just below the coil handle.

To adjust the coil in accordance with the calibration curves the procedure is as follows: Set the tuning dial to read 120, tune the frequency meter to the high frequency edge of the band covered by the coils, and adjust the oscillator coil trimmer until the signal is picked up. The beat oscillator should be in operation. When adjusting some of the coils, particularly those covering the 3.5 to 4. megacycle band, two settings of the oscillator coil padding condenser may be found which will tune in the signal. Of these, the higher frequency setting is correct.

Where compression type trimmers are used in the oscillator coils, the high frequency setting will be that at which the adjustment screw is turned furthest counter-clockwise, giving the lower capacity. When air dielectric type trimmers are employed, it is usually only possible to tune the oscillator to the high frequency side.

A check for the correct setting of the padding condenser after making adjustment outlined above, is to set the tuning dial at 20 and change the frequency meter setting to the low frequency end of the band. If the signal is received within two or three dial divisions either side of 20, the oscillator coil adjustment is correct. If, however, the low frequency limit of the band cannot be found, or if when found it gives a widely different reading than those indicated by the calibration curves of the receiver, it is probable that the oscillator coil has been incorrectly adjusted.

In making these adjustments it is almost essential to employ a frequency meter operating at its fundamental frequency, since correct setting is difficult to determine when using the harmonic type of frequency meter.

When the oscillator padding condenser is correctly set, the detector coil trimmer condenser may be adjusted. This is best done by tuning in a steady signal, either modulated or unmodulated, and adjusting the detector coil trimmer condenser for maximum response. The signal may be at any point in the band. If the operator is experienced in such work, the best setting may be determined by ear. If, however, difficulty is experienced in obtaining the correct adjustment, it is necessary to employ some form of output measuring device, such as an output meter, connected to the speaker terminals, or a 0 to 1 milliammeter connected in the headphone jack.

When adjusting the 14. to 14.4 megacycle detector coil, for instance, the trimmer setting is not critical to the ear and the use of the output device is desirable.

The detector circuit trimmer condenser, mounted in the receiver just at the right-hand side of the ganged tuning condenser, serves a special purpose in aligning the general coverage coils and its adjustment should not be changed.

Intermediate Frequency Amplifier Alignment

The adjustment of the intermediate frequency amplifier has negligible effect upon the calibration of the receiver. The alignment may be checked or changed slightly without affecting the accuracy of the oscillator or detector coil condenser adjustment.

The alignment check for either the FB-7 or FB-X receivers may be made as follows: Tune in a steady signal from a local oscillator or frequency meter anywhere on the dial. The beat frequency oscillator should be on and, in the case of the FB-X, the signal should be tuned as for single signal reception with the crystal in the series position. The volume control should be adjusted so that there is no possibility of overloading any of the tubes. The adjustment of the various I. F. tuning condensers may then be varied slightly in order to obtain the setting giving the loudest signal.

If the correct adjustment is difficult to determine accurately by ear, an output indicating device should be employed in the same manner as that used in adjusting the detector coils. It may be found that when adjusting certain of the I. F. condensers that the beat note is changed slightly. This is normal and does not affect the accuracy of adjustment.

INSTALLATION AND OPERATING INSTRUCTIONS

ON

NATIONAL "FB-7"

(6 VOLT TYPE)

TUBES. Seven tubes are required for the "FB-7" receiver, exclusive of the power pack, as follows:

1st Detector	77	2nd Detector	237
High Frequency Oscillator	236	Beat Oscillator	236
1st Intermediate	78	Output Amplifier	89
2nd Intermediate	78		

The positions of the various tubes are shown in the attached plan of the receiver.

It is understood that in order to secure best results, tubes of recognized quality and average characteristics should be employed.

POWER SUPPLY. The special NATIONAL Type No. 5886-AB power pack is recommended for obtaining the best results where not more than 1 watt of audio power is necessary. This unit supplies 180 volts maximum at full load and 6 volts at 2.2 amperes to the heaters. All voltage dividers, etc., are built into the receiver.

The power pack employs the 280 rectifier tube. The use of mercury vapor tubes is not recommended.

If desired, the "FB-7" may be operated from a suitable filament transformer with 180 volts of B-battery. The total current drain at this voltage is approximately 30 m. a., and varies somewhat with the setting of the volume control.

ANTENNA. Antenna dimensions are not at all critical, but some experimentation is advised in order to determine the length of wire giving the best performance. If, for instance, local noise level or static is particularly high, a short wire will probably be preferable.

Referring to the circuit diagram, it will be seen that the antenna circuit consists of a primary coil and a series condenser. This arrangement is used to eliminate antenna tuning effects due to capacity or inductive loading.

Special antennas, such as the doublet and various forms of resonant antennas that are normally employed without a ground, may be connected to the antenna and ground terminals provided the ground post is disconnected from the chassis. This may be done very easily since an insulated mounting is employed.

OUTPUT CIRCUIT. The plate circuit of the output tube is brought to the output tip jacks located at the rear right-hand corner.

When using the 180 volt supply, the plate current of the 89 tube is less than 16 m. a., which will not appreciably affect the performance of any properly designed magnetic speaker. Certain types, however, such as the inductor dynamic, require a filter system, which may consist of a 1 to 1 transformer or a 30 henry choke, and a 1. mfd. condenser. The permanent magnet dynamic speakers will give excellent results and their use is recommended.

A headphone jack for connecting the phones in the plate circuit of the second detector, is located at the rear left corner. Inserting the phone plug automatically disconnects the grid circuit of the 89 tube, the plate circuit remaining unchanged.

CONTROLS. The middle knob is the main tuning control, operating the ganged high frequency oscillator and first detector tuning condensers. Frequency increases with dial reading.

The left-hand toggle switch opens the main B supply circuit, leaving the heaters lighted, and is particularly useful for turning off the receiver during transmission periods. If B battery plate supply is employed, the switch should be thrown to the "Off" position at all times when the receiver is not in use.

The right-hand toggle switch controls the beat oscillator, which is coupled to the input circuit of the second detector and is used primarily for the reception of c. w. signals, although it is helpful in locating weak phone carriers.

Beat oscillator tuning may be adjusted by means of either of the adjustment screws located at the top of the oscillator coil shield, mounted between the 237 and the 236 tubes. Normally, the oscillator is adjusted to the frequency of the intermediate amplifier, as determined by the pitch of the background hiss. Improved selectivity may be obtained by detuning the oscillator from the i. f. by approximately 1000 cycles. Such detuning will emphasize one side of the carrier beat.

The knurled disc below the tuning knob is the volume control, calibrated in steps of approximately 8 db. from 1 to 9. The signal which is just audible with the control full on, that is, at 1, will be R-1 on the audibility scale; a signal which is just audible with the control set at 8, will be R-8, etc.

INTERMEDIATE FREQUENCY AMPLIFIER. The i. f. amplifier is tuned to a frequency of approximately 485 k. c., tuning being accomplished by means of the condenser adjusting screws located at the top of the intermediate frequency transformer shields.

COIL AND TRIMMER ADJUSTMENT.

A parallel padding, or range adjusting, condenser is mounted inside each of the oscillator coils, and may be set with a screw driver inserted in the hole just below the coil handle. When properly adjusted, the tuning will check the calibration curves closely. Tightening the screw will give higher dial readings.

The detector coils for full coverage (1500-20,000 k. c.) are trimmed by a condenser mounted between the gang tuning condenser and the detector tube. This condenser also serves as an antenna compensator for these coils only.

Individual trimmer condensers are mounted inside each band-spread coil, so that the r. f. and detector stages may be brought into exact alignment with the band properly centered on the dial. The high frequency edge of all the bands is at 120 and the low frequency edge at 20.

The setting of these trimmer condensers, particularly those of the oscillator coils is quite critical. If it is found necessary to readjust any of them, it will be noticed that the frequency will creep for a few seconds after the adjustment is made, particularly on the two higher frequency bands.

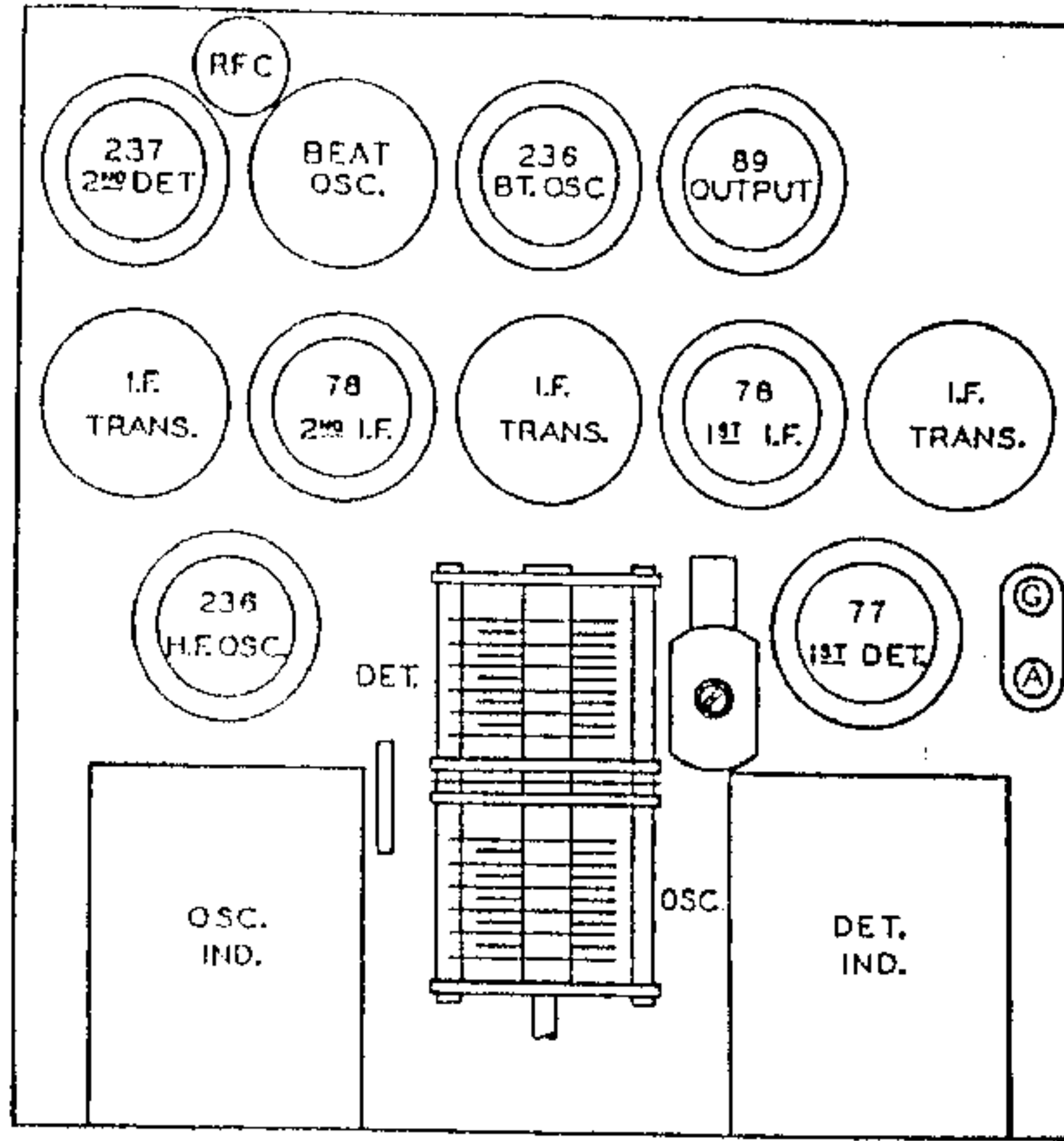

Tube Locations — Plan

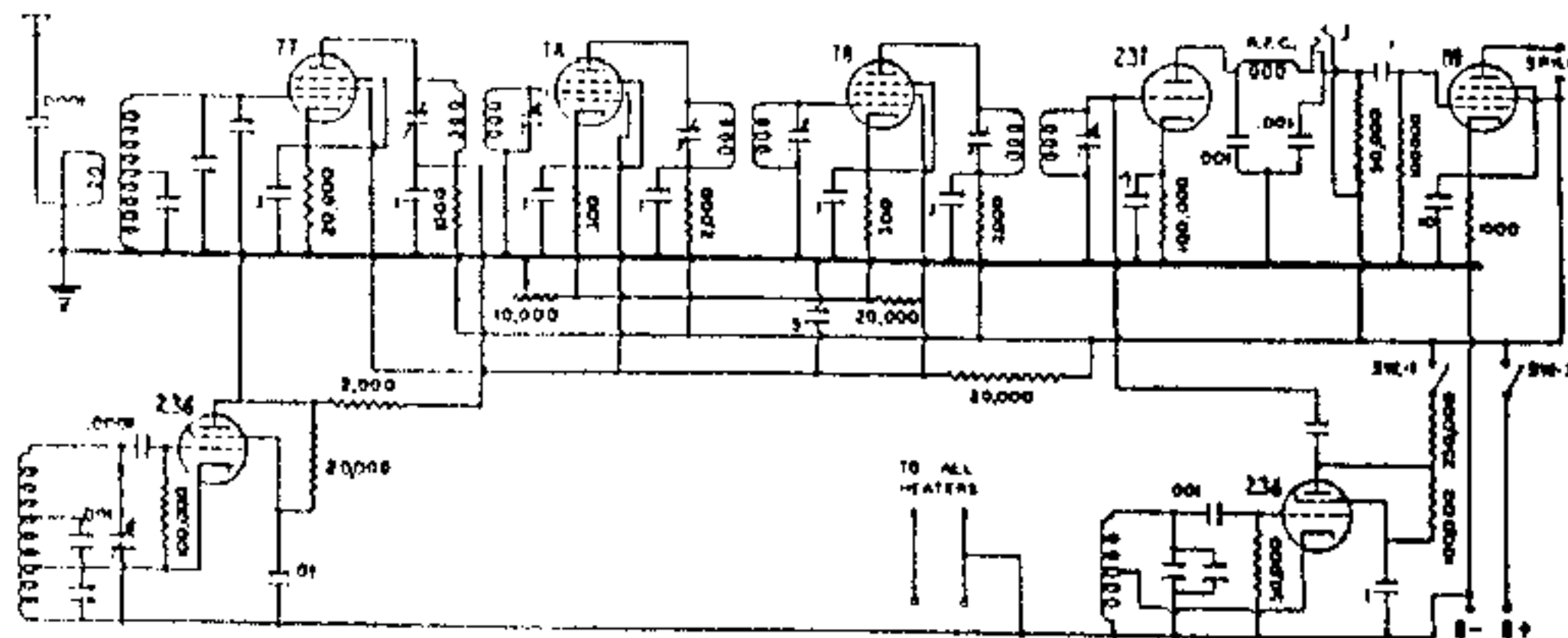

**Circuit Diagram of F-B 7
(6 Volt Type)**

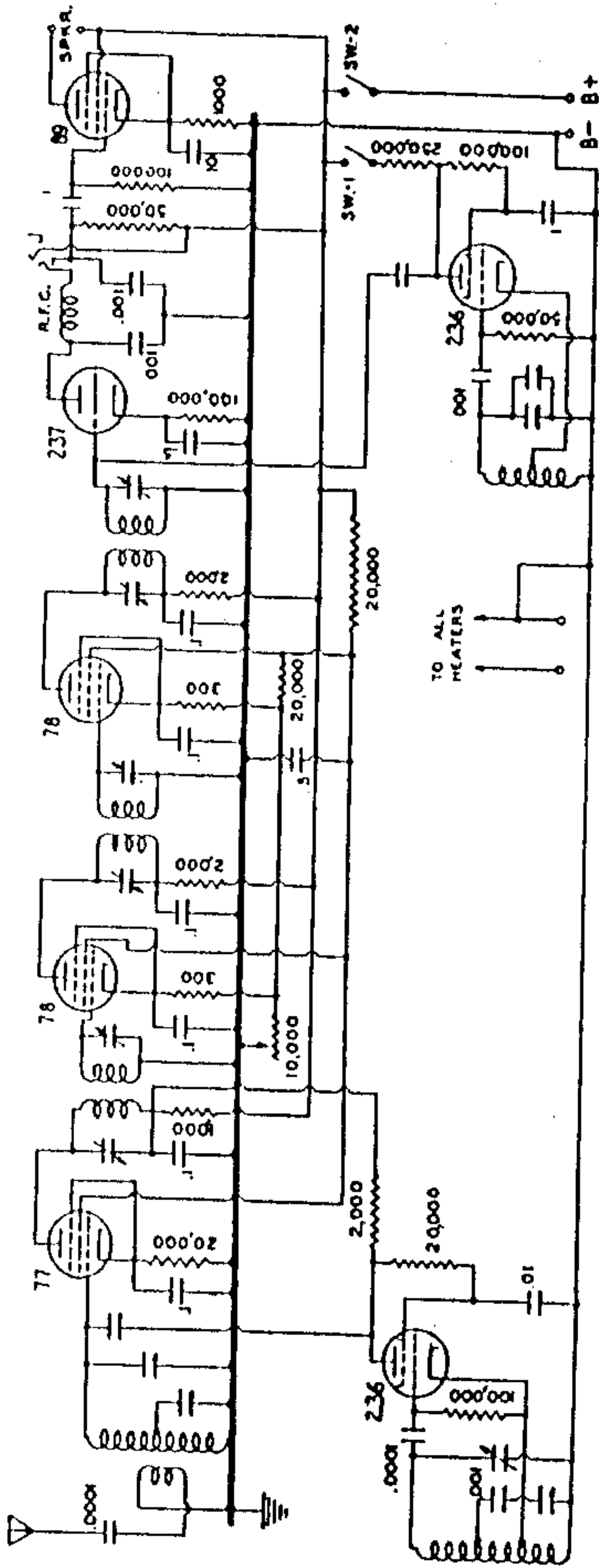

Circuit Diagram of F-B 7
(6 Volt Type)

Alignment Instructions for FBX-FBXA

Single Signal Receivers

BEFORE attempting to check the alignment or adjust a single signal receiver it is essential that the operator be familiar with the principles involved and the type of performance to be expected.

A receiver of this type is simply a superheterodyne which may be adjusted to have extremely high selectivity on c.w. signals. The effective width of the selectivity curve is only a few cycles, usually between 20 and 100. This means that when tuning in a given c.w. signal, tuning is going to be very sharp and the dial must be turned slowly in order to avoid missing the signal entirely. As compared to the straight superheterodyne, the single signal receiver is about 100 times as selective. The straight super will pick up a signal and will reproduce both sides of the audio beat note at about the same strength; that is, the carrier whistle may be varied from either side of zero beat up to about 3000 cycles when the receiver is tuned and the whistle will remain about the same strength at any pitch. The s.s. receiver, however, being 100 times as sharp, will not perform in this manner, but as the receiver is tuned across the carrier the audio response will be very sharply peaked at one certain pitch of the carrier whistle. Detuning the receiver a small fraction of a degree, while it changes the pitch only slightly, will make the signal much weaker, since it has been detuned from the sharp selectivity peak.

It is evident, therefore, that the great selectivity available shows up as a peak in the audio response and when the receiver is in operation all signals, after being correctly tuned, will peak at the same audio frequency.

General Superheterodyne Theory and the Explanation of Single Signal Operation

(It is extremely important that these paragraphs be very carefully studied, if a full understanding is to be had of the detailed data on adjusting Single Signal receivers)

To those who are not entirely familiar with the operating principles of a superheterodyne, the following explanation may be of interest:

It is the function of the first detector and high frequency oscillator of a super to convert a high frequency signal to the frequency of the intermediate amplifier. If, for instance, a 7000 k.c.

signal is being received, the high frequency oscillator, in the case of the FB- receivers, will be tuned to 7500 k.c. producing a beat with the signal equal to the difference between these two frequencies; that is, 500 k.c., the frequency of the I.F. amplifier. (These figures are not exact since the I.F. of the FB- receivers is about 495 k.c.) The 500 k.c. beat is amplified in the I.F. amplifier and is detected or de-modulated in the case of phone signals at the second detector. When receiving c.w. signals a beat note is obtained by the use of a separate beat oscillator coupled to the second detector and operating at, or close to, the intermediate frequency. If the beat oscillator is tuned exactly to 500 k.c. and if the signal mentioned above is tuned to give an I.F. beat of exactly 500 k.c., it is evident that the receiver as a whole will be tuned to zero beat.

An audible beat note may be obtained by doing either one or two different things. The first is to change the tuning of the high frequency oscillator (by means of the tuning dial) slightly, so that it will produce a different I.F. beat with the signal. For example, suppose the dial is changed so that the high frequency oscillator oscillates at 7501 k.c.; the I.F. beat will now be 501 k.c., which will be amplified as before by the intermediate amplifier, but when reaching the second detector will produce a 1 k.c. (thousand cycle) audio beat with the beat oscillator, which is operating at 500 k.c. as before. Similarly, the tuning dial could be moved in the other direction, so that the high frequency oscillator is tuned to 7499 k.c., in which event the I.F. beat would be 499 k.c. and the audio beat note would be a thousand cycles but on the other side of the carrier.

The selectivity of the I.F. amplifier is such that a signal detuned from it by only one kilocycle (.2 of 1%) will still be amplified almost as much as a 500 k.c. signal, although there will of course be some loss in gain.

The other method of getting an audible beat note is to leave the signal tuned exactly, as in the original case, with the 500 k.c. I.F. signal but to detune the beat oscillator so that it operates at say 501 k.c. The I.F. amplifier is now exactly in tune with the I.F. signal and will amplify it at full efficiency. The beat note will be 1000 cycles, as before. This method, wherein the signal is tuned exactly and the beat obtained by detuning of the beat oscillator, is fundamentally that used in any

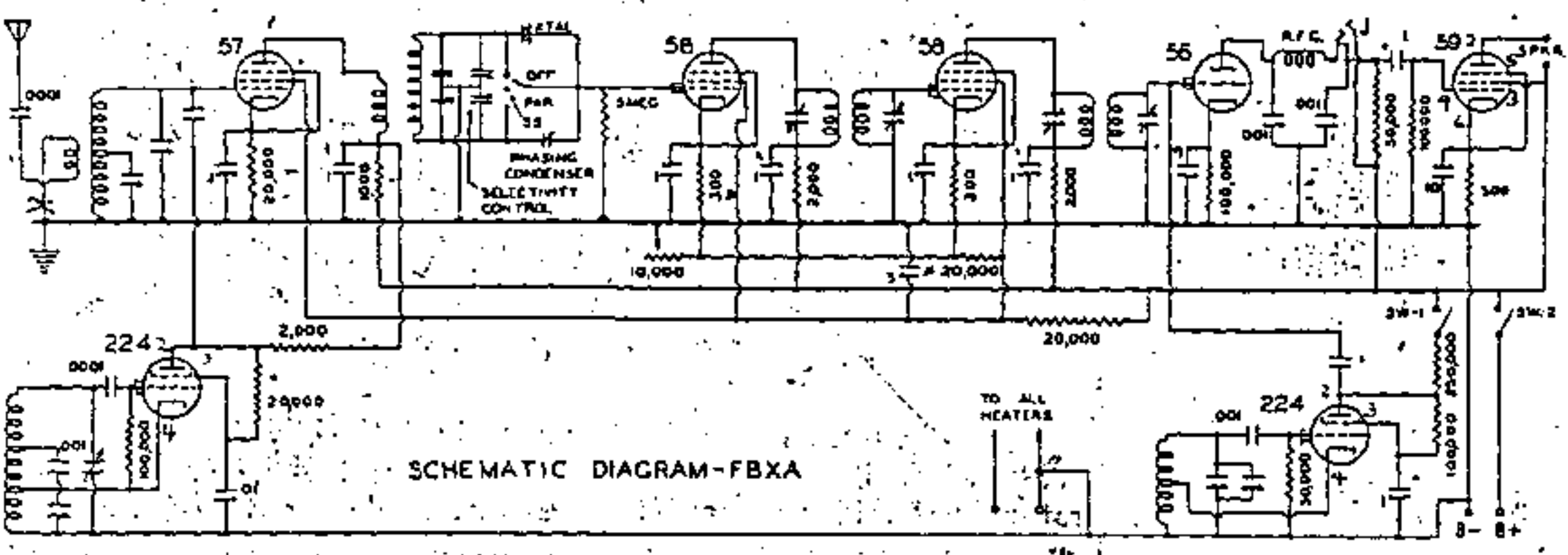

single signal or semi-single signal receiver. It is evident that changing the tuning dial slightly will detune the I.F. signal from the I.F. amplifier so that it will not be amplified as much, causing a corresponding decrease in the strength of the audio beat note: thus, if tuning is changed in such a way as to raise the pitch of the beat note, the signal will be weaker. Similarly, if the tuning is changed to lower the pitch down toward the zero at region, the signal will be weaker. If the tuning is still further changed, so that the audio note passes through the zero beat region, and "up the other side of the carrier," the signal will become weaker still. The falling off in signal strength, as the receiver tuning is changed, is due entirely to the selectivity of the I.F. amplifier. Suppose now that the I.F. amplifier has very high selectivity, as is the case when a crystal filter is employed in single signal reception; the crystal will pass only a very narrow band of frequencies, say from 499.9 k.c. to 500.1 k.c. It will be necessary, therefore, to tune the signal so that the I.F. beat is exactly 500 k.c., and in order to obtain an audible beat note, the beat oscillator **MUST** be detuned. If the beat oscillator is set as before at 501 k.c., the beat note will be 1000 cycles. Detuning, as in the above case, will make the signal practically inaudible, except at this one pitch, and "the other side of the carrier," or audio image, will be almost entirely suppressed.

With the receiver tuned exactly so that the crystal will pass the I.F. beat, the beat oscillator may be adjusted to give any desired audible beat note. In the above case, the beat oscillator being set at 501 k.c. produced a 1000 cycle beat at which all signals would be peaked. If the beat oscillator were set at 502 k.c., all signals would be peaked at 2000 k.c.

If the receiver tuning is left alone, then, the beat oscillator may be adjusted to give any desired pitch without changing the signal strength. Any change in tuning which changes the pitch of the audio signal will greatly weaken the signal.

The main point to remember when considering single signal receivers is that they are simply ultra selective superheterodynes, which must be tuned exactly to the signal and that the beat oscillator must be detuned from the crystal frequency in order to obtain an audible beat note.

Preliminary Adjustments—The I.F.

From the above explanation, the reader will see that it is absolutely essential that the I.F. transformers be aligned to the crystal, since the two must work together. This alignment may be accomplished in a number of ways. If the I.F. transformers are far out of adjustment, it is necessary to connect an external crystal oscillator which uses the crystal from the receiver. This oscillator is put in operation and is coupled to the first detector of the receiver. In most cases no actual connection will be required since the field from the oscillator will be sufficiently strong to be picked up, even with the I.F. far out of adjustment. If coupling is required, a lead twisted around the grid cap of the detector tube and run near the oscillator tank coil, will be suitable. The beat oscillator is turned on and adjusted until the crystal signal is picked up. The pitch of the beat note is not important as long as it is well inside the audible range.

All the I.F. transformers are now adjusted for maximum signal. This adjustment need not be made with any great degree of precision, since the crystal will not oscillate at exactly the same frequency to which it will be resonant in the receiver. The crystal selector switch should be in the "off" position.

The crystal may now be removed from the oscillator and installed in the receiver. Throw the crystal selector switch to connect the crystal in the series position for single signal reception. Set the selectivity control for maximum selectivity; that is, with the edge of the knurled disk moved as far as it will go toward the back of the receiver.

Now, tune in a steady signal from a local oscillator or monitor. Tuning very slowly across the carrier, there should be one point at which the signal will peak very sharply. The audio pitch of this peak will be nearly the same as the pitch of the beat used when the crystal oscillator was being picked up.

The Beat Oscillator

Once the peak has been found, it would be well for the operator to familiarize himself with the action of the beat oscillator control by changing its tuning in order to obtain an audio note which is most pleasing to copy, or which coincides with any peaks in the loudspeaker or headphones. It makes little difference to which side of the audio beat, the beat oscillator is tuned. After a satisfactory pitch has been found, tune the signal by means of the tuning dial so that the signal goes down through zero beat and up to approximately the same pitch on the other side. This response is, of course, much weaker than that of the peak and it may be necessary to turn up the volume control in order to obtain fair volume.

Final Phasing Adjustment

The phasing, or balancing, condenser is now adjusted until the signal is WEAKEST. The adjustment should preferably be made with a bakelite or wooden screw driver in order to avoid extraneous capacity effects. This completes the phasing adjustment.

The Selectivity Control

The action of the selectivity control may now be checked. With the receiver tuned exactly as it was when adjusting the phasing condenser, the selectivity control disk should be rotated and it will be found that the signal will be loudest at a certain setting. This setting is usually found when the edge of the disk is moved about two-thirds of its rotation toward the front of the set. The setting giving this maximum response is that at which the selectivity of the crystal filter is minimum. Since even at this minimum selectivity the crystal filter is much more selective than the straight super, the signal will be weaker than that obtainable when the crystal is cut out.

When a pure steady signal is carefully tuned to a single signal peak, the selectivity control should have practically no effect upon signal strength. If there is any form of modulation, however, the signal will be loudest when the selectivity control is set for minimum selectivity, since this adjustment allows a greater width of signal or modulation to be passed.

Final I.F. Adjustment

The final adjustment of the I.F. transformers may now be made. Set the control for maximum selectivity, carefully tune in a steady signal until it is exactly on the crystal peak, and adjust each of the I.F. transformer tuning condensers for maximum signal strength. In almost all cases where the I.F. amplifier has once been aligned to the crystal, this check is all that would be required, and it is not necessary to put the crystal in an external oscillator. Even if the I.F. amplifier is considerably out of alignment, the crystal frequency may be found by employing a strong local signal from a monitor or frequency meter, slowly tuning across it while listening for a peak in the audio beat note. If the peak is found at a very high audio pitch it will be necessary to change the tuning of the beat oscillator so that the audio peak will be well inside the limits of audibility. It is probable that if the peak signal is found at all, the I.F. amplifier will not be far out of tune and the readjustments required will be small.

Where the I.F. transformers are tuned with air dielectric condensers, the adjustments when once made are permanent and need only be checked when new tubes are substituted, provided of course the receiver is not subjected to severe mechanical shocks or vibration. I.F. transformers tuned by compression type mica dielectric condensers, on the other hand, should be checked frequently, since the capacity of such condensers is changed by temperature and humidity fluctuations. These statements are equally applicable to the beat oscillator circuits.

Checking Crystal Action

The crystal response, or crystal activity, may be easily checked as follows: With the signal tuned in exactly as mentioned in the previous paragraph and the selectivity control set at maximum selectivity, throwing the crystal selector switch from the single signal, or central, position to the straight super connection should not cause any change in signal strength. There will, of course, be a great increase in tube hiss, background noise and interfering signal, but the actual strength of the desired signal should not change. It is possible, of course, to obtain a louder signal in the straight super connection by resetting the selectivity control and this is quite normal. The fact that a signal is weakened when using the crystal filter is relatively unimportant, inasmuch as the filter is only used when interference or static is present, and such interference will be made about



The improved model National Air Dielectric condenser-tuned I.F. transformer as used in the National FB7A and FBXA receivers

100 times weaker, thereby greatly improving the readability of the signal.

A crystal which is found to be a poor resonator should be carefully removed from the holder and both crystal and plates cleaned with alcohol, gasoline, carbona, ether, or some similar fluid. In reassembling the holder care must be taken to see that the crystal is free between the plates; that is, that there is a suitable air gap (usually two or three thousandths) between the upper plate and the crystal and that the crystal is free to move sideways in any direction. Many types of holders are of such construction that the cover must not be screwed on tightly since this exerts pressure upon the upper plate, sometimes distorting it to such an extent that it exerts pressure upon the crystal itself. Under such conditions the crystal will be almost completely inoperative. Other types of holders are supplied with a clamping screw which must be loosened in order to free the crystal.

The operation of the crystal in the parallel connection may be checked in a similar manner to that employed to check the crystal activity. The

signal is tuned in in the series or single signal position, and then the crystal selector switch is thrown to the parallel position. Unless the test oscillator emits an exceptionally pure signal, the beat note will appear to change slightly or to have two frequencies. Re-tuning the signal very carefully should show a sharp minimum response in the audio beat note, this minimum being very close to the same audio pitch at which the signal peaked in the single signal position of the switch. In other words, with the crystal in the parallel position there will be a point where the audio beat note will be very weak; just the opposite of the single signal reception. In this case, the crystal acts as a trap to reject an I.F. signal tuned exactly to its frequency. Under actual operating conditions the parallel connection is seldom used, but is helpful under certain circumstances; for instance, if two phone stations are close together, causing a bad heterodyne, it is possible, provided the interfering station has a steady carrier, to tune the receiver so that the undesired signal is rejected by the crystal as evidenced by a sharp decrease in the heterodyne interference.

Notes on Band Spread Coils

The band spread coils for the FB- receivers are carefully aligned at the factory and, as a general rule, it is not necessary to make readjustments. Since, however, there is bound to be some variation in individual receivers, it is impossible to align the coils at the factory so that they will check exactly with the calibration curves. Similarly, antenna characteristics will vary, making it desirable or even necessary in many cases to readjust the detector coil trimmer condenser.

When all adjustments are correct, the receiver will, of course, operate at its best; that is, with maximum sensitivity and minimum image frequency reception. In any superheterodyne, however, especially those not having pre-selection before the first detector, images and repeat points are to be expected to some extent, and while such interference may be reduced by proper adjustment of the detector coil as outlined below, their presence does not necessarily indicate incorrect adjustment.

The amateur band spread coils for the FB- receivers are adjusted by means of a suitable monitor or frequency meter. The position of the band on the dial is determined entirely by the adjustment of the oscillator coil padding condenser, which is mounted inside the oscillator coil and which may be adjusted by means of a screw driver through the hole just below the coil handle.

Calibration Curves

To adjust the coil in accordance with the calibration curves the procedure is as follows: Set the tuning dial to read 120, tune the frequency meter

to the high frequency edge of the band covered by the coils, and adjust the oscillator coil trimmer until the signal is picked up. The beat oscillator should be in operation. When adjusting some of the coils, particularly those covering the 3.5 to 4. megacycle band, two settings of the oscillator coil padding condenser may be found which will tune in the signal. Of these, the higher frequency setting is correct.

A check for the correct setting of the padding condenser after making adjustment outlined above, is to set the tuning dial at 20 and change the frequency meter setting to the low frequency end of the band. If the signal is received within two or three dial divisions either side of 20, the oscillator coil adjustment is correct. If, however, the low frequency limit of the band cannot be found, or if when found it gives a widely different reading than those indicated by the calibration curves of the receiver, it is probable that the oscillator coil has been incorrectly adjusted.

It is absolutely essential that the first adjustment be made at the high frequency end of the band; that is, at 120 on the dial. If the operator attempts to set the oscillator padding condenser at the low frequency end, he is almost sure to find that the calibration will run out and be off as much as ten or fifteen degrees at the high dial readings.

In making these adjustments it is almost essential to employ a frequency meter operating at its fundamental frequency since correct setting is difficult to determine when using the harmonic type of frequency meter.

Antenna Trimmer

After the oscillator padding condenser is correctly set, the detector coil trimmer condenser should be adjusted. This is best done by tuning in a steady signal, either modulated or unmodulated, and adjusting the detector coil trimmer condenser for maximum response. The signal may be at any point in the band. If the operator is experienced in such work, the best setting may be determined by ear. If, however, difficulty is experienced in obtaining the correct adjustment, it is necessary to employ some form of output measuring device, such as an output meter, connected to the speaker terminals, or a 0 to 1 milliammeter connected in the headphone jack.

The detector circuit trimmer condenser, mounted in the receiver just at the right-hand side of the ganged tuning condenser, serves a special purpose in aligning the general coverage coils and its adjustment should not be changed.

It is also important to re-check the adjustment of the detector coil trimmer condenser when any change is made in the receiving antenna or feeders.

The operator must realize that this detector coil adjustment, while extremely simple and easily made, is one of the most important.

Air dielectric padding condensers are used in all oscillator coils, both general coverage and band spread, to insure permanence of calibration and freedom from frequency drift. Condensers of this type, however, are not necessary in the detector coils since the trimmer capacity required is very small and a mica condenser having small capacity may be built for very low mechanical strain on the plate or dielectric so that the effects of temperature variation will be negligible. As a matter of fact, the bulkier air dielectric condensers, when placed in the field of the coil, will introduce losses and broaden the tuning of the input circuit.

Catalog No.		Range
AB 20	(air padded osc.)	20 Meter Band Spread
AB 40	(air padded osc.)	40 Meter Band Spread
AB 80	(air padded osc.)	80 Meter Band Spread
AB 160	(air padded osc.)	160 Meter Band Spread
FB AA	(air padded osc.)	34000 to 18000 Kc
FB A	(air padded osc.)	19500 to 11400 Kc
FB B	(air padded osc.)	11700 to 7000 Kc
FB C	(air padded osc.)	7300 to 4000 Kc
FB D	(air padded osc.)	4200 to 2400 Kc
FB E	(air padded osc.)	2500 to 1500 Kc
FB F	(air padded osc.)	1500 to 800 Kc

The list price of coils for all ranges is \$10.00 per pair. Unwound coil forms, complete with trimmer and coil handle are available at a list price of \$3.65 each, and designated by the Catalog Symbol XR-39.

POWER PACKS AND TUBES

THERE are several makes of tubes that give very satisfactory performance in broadcast receivers, and yet will not operate satisfactorily as electron coupled oscillators or I.F. amplifiers in the particular circuit employed in the FB type of high frequency receivers. It is for this reason that we so strongly recommend the use of RCA Radiotrons.

The heater circuits of the FB7, FB7A, FBX, and FBXA receivers draw $9\frac{1}{2}$ amperes. As a result, there is a voltage drop of approximately .3 volts in the cable. National Type 5887 and 5897 power packs are designed to deliver 2.8 volts to the heater circuit in order to offset the voltage drop in the cable, and thus deliver the correct voltage (2.5) across the heater terminals of the different tube sockets. This voltage is critical. Should the voltage be less than 2.25 when measured across the socket terminals, erratic and totally unsatisfactory operation may result. Consequently, it is extremely important when other than a standard National power unit is employed to see that the tubes are getting the proper heater voltage. In connection with a home made power supply, it is impractical to use standard broadcast set replacement power transformers having a 2.5 volt heater winding, as such transformers will not deliver sufficient heater voltage to properly operate the receiver.

Experience has shown that in well over fifty percent of the cases where unsatisfactory results have been had with one of the FB type receivers, the difficulty has been due entirely to the use of a power pack that did not supply full heater voltage when measured at the tube sockets.



CALIBRATION CURVES FOR BOTH GENERAL COVERAGE AND BAND SPREAD COILS

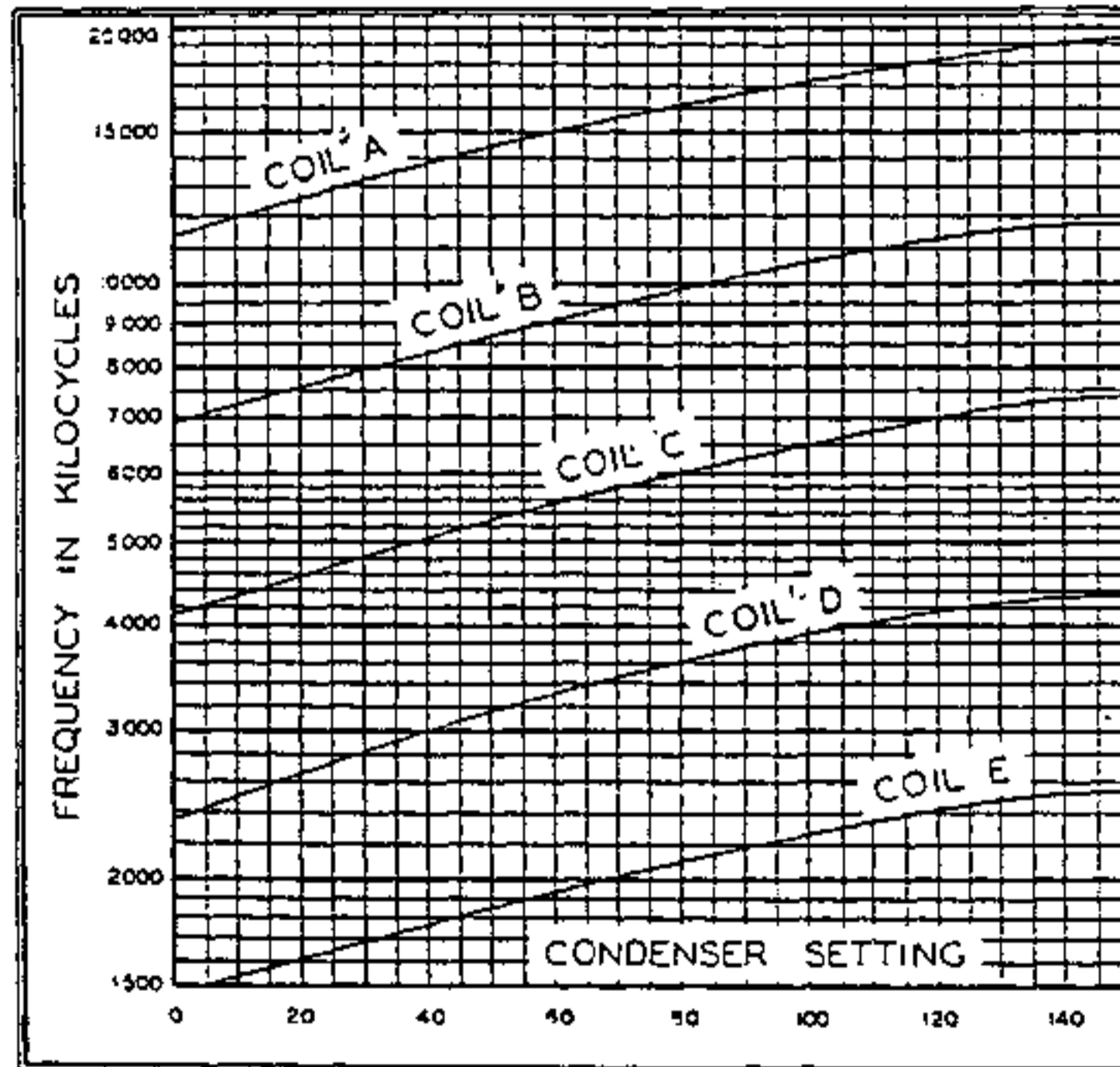
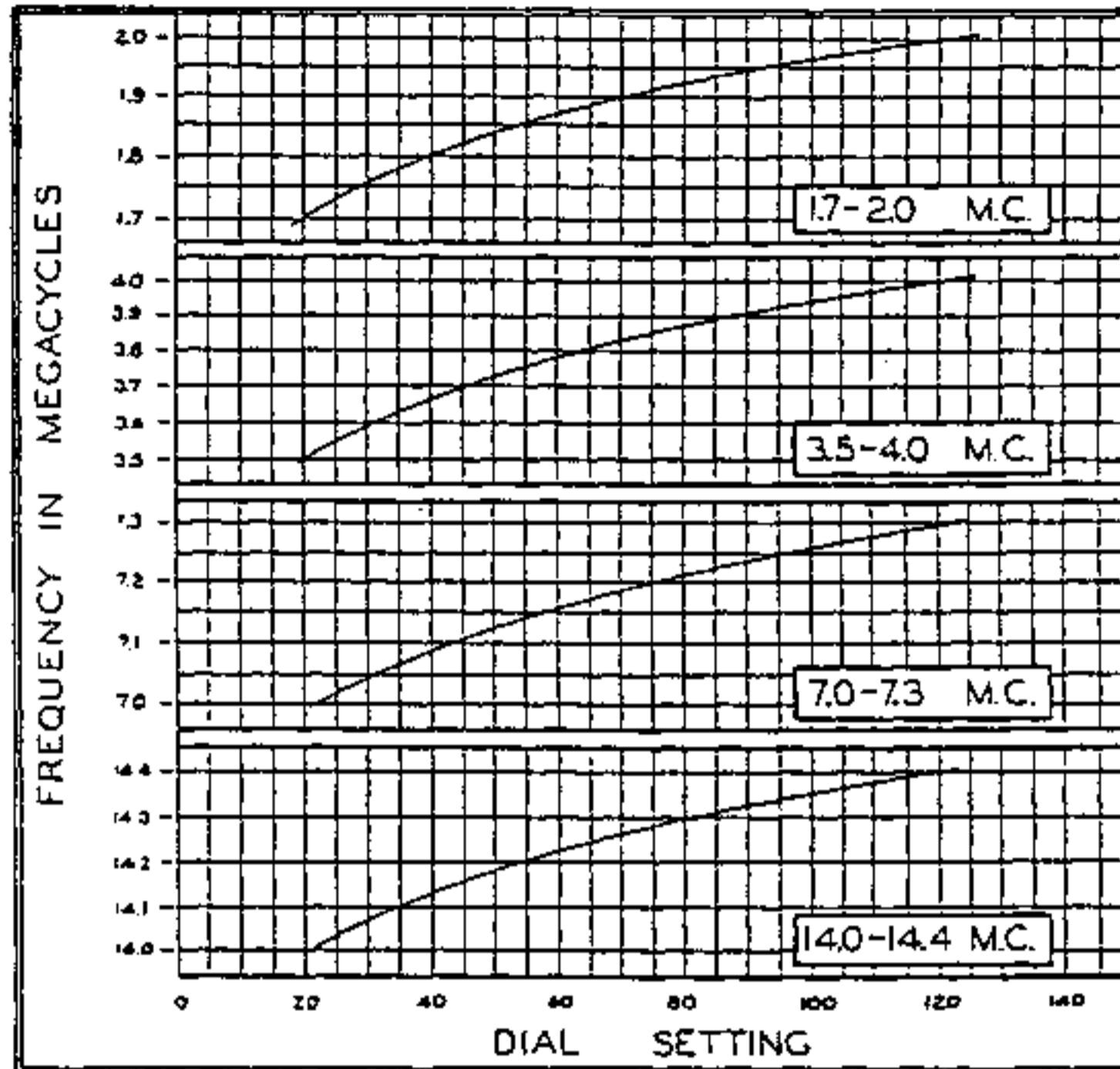

NATIONAL COMPANY, INC.

61 Sherman Street

Malden, Mass.



NATIONAL

"FB-7"

Amateur Type

SHORT WAVE RECEIVER

The FB-7, designed primarily for the experienced amateur operator, is a seven tube receiver having exceptional sensitivity, selectivity, stability, and other characteristics essential in order to contend with the crowded conditions of the amateur C. W. and phone bands. Ample sensitivity and selectivity are assured through the use of a circuit employing two stages of high gain I. F. amplification (six tuned circuits) while individual filtering of all circuits, including the oscillators, together with thorough shielding, results in unusual stability. There is no pulling-in or blocking by strong local signals, and frequency drift in both high frequency and beat oscillators has been eliminated. Variation of the volume control has no appreciable effect on the pitch of C. W. signals, even at 14. mc.

The receiver is compact, being only 11½" x 12", and is shaped to conserve space on the operating table as much as possible.

The full vision dial, plug in coils, send and receive switch, beat oscillator switch, calibration chart, etc., *all on the front panel*, result in an ease and convenience of operation that is possessed by no other receiver.

FB-7 completely wired including 80 meter coils, less tubes, \$55.00

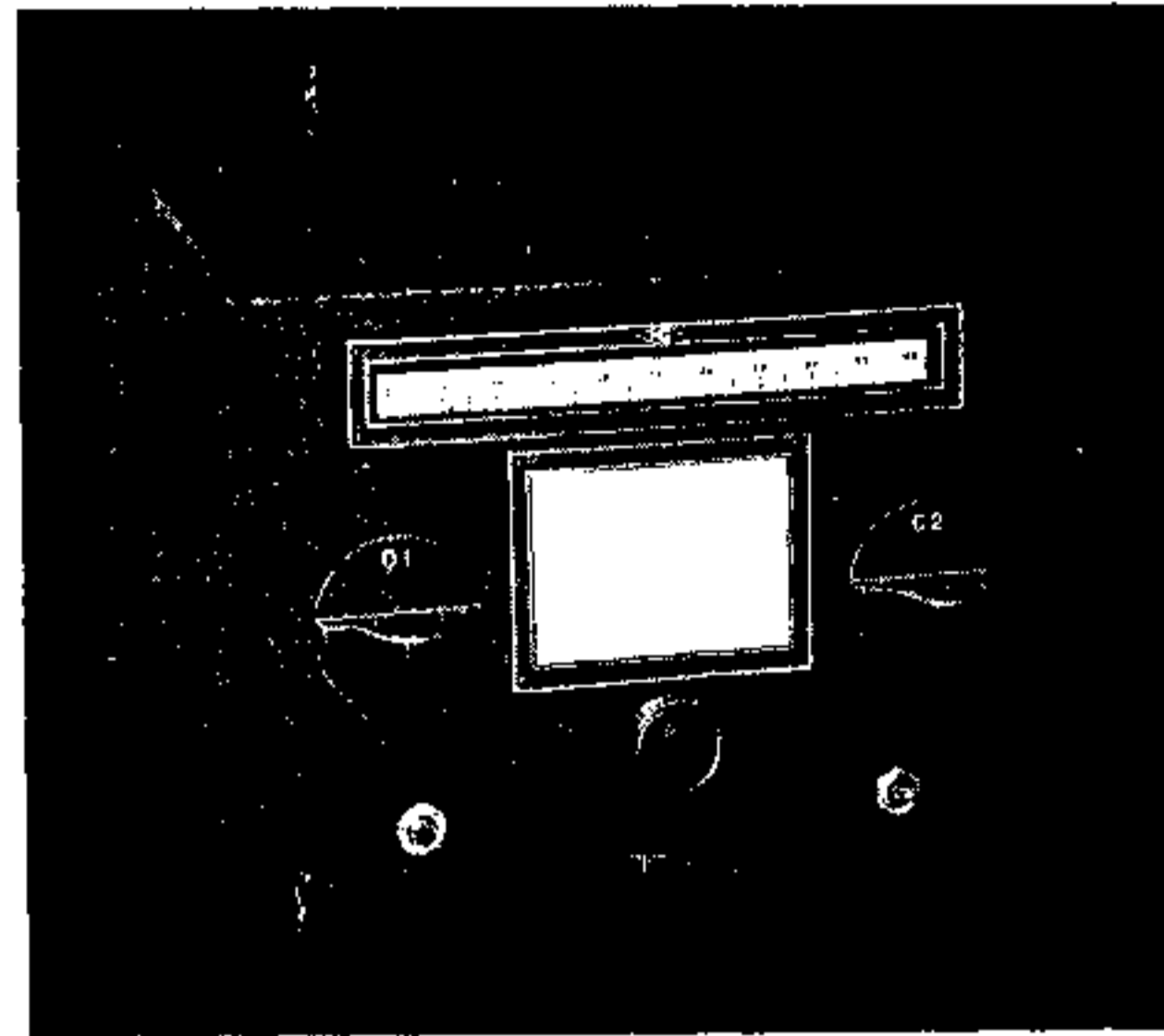

Outstanding Features:

- High Selectivity and Sensitivity
- Electron Coupled Oscillators — No Frequency Drift
- Uniform Gain over Entire Frequency Range
- Double Shielding
- Absolute Single Control Tuning — No Trimmer
- Two I. F. (High Gain) Stages
- New NATIONAL Type AGS Litz-wound I. F. Transformers with trimmer adjustments on top
- Tuning Curves on Front Panel
- Gain Control Calibrated in "R" Units
- High Signal to Noise Ratio
- One-Hand Tuning
- Front of Panel Coil Change
- Shielded "R39" Coils Changed from Front of Panel
- S. F. L. 270° Tuning with Full Vision Velvet Vernier Dial
- Seven Tubes without Rectifier
- Panel Switch for cutting B Voltage during Transmission
- Band Spread and Full Range Coils
- Amateur Bands Spread over 100 Dial Divisions
- Full Range 20 m.c. to 1500 k.c.
- "Offset" c.w. Beat Tuning
- Beat Oscillator Switch on Panel
- Phone Jack in 2nd Detector Output Circuit
- Speaker Driven by '59 as Class "A" Pentode
- Mechanical Filter (Quartz Crystal) Available for Full Single Signal Reception
- "Doublet" or standard type Antenna System

TUBES

1.....	56
1.....	57
2.....	58's
1.....	59
2.....	24's

SINGLE-SIGNAL RECEPTION

Fully realizing the tremendous advantages of so-called "single signal" reception in connection with c.w. reception on some of the more congested bands, the "FB-7," like the "AGS," has been designed so as to be readily adaptable to this new type operation. High inherent circuit stability, high I. F. gain, special shielding and proper chassis space, directly adjacent to the 1st I. F. transformer and tube, make possible the ready addition at any time of a mechanical filter (quartz crystal) with its associated "selectivity control" condenser and multi-point switch.

Contrary to the widespread impression on the part of many amateurs, single signal reception is primarily for c.w. work, and not for 'phone band use.

The "FB-7" I. F. amplifier is so designed as to have the maximum selectivity possible for 'phone band use without serious sacrifice of intelligibility.

If desired, the single signal version of the "FB-7" may be obtained as a complete unit by specifying the Catalog Symbol "FBX," and at an additional list price of \$20.00 above that of the standard model "FB-7."



NATIONAL RADIO PRODUCTS

NATIONAL

REGULAR and BANDSPREAD

"FB-7" COILS

The plug-in coils employed in the "FB-7" are essentially the same as those developed originally for the "AGS" receiver. The windings are on accurately threaded forms of R-39, the low-loss dielectric, and are protected from damage by an outside sleeve of special bakelite. This bakelite sleeve does not come in contact with the windings themselves and consequently does not detract from the low-loss features contributed by the R-39 coil forms.

The metal handle at the end of the form not only serves as a convenient grip for inserting and removing the coils from the sockets, but also completes the coil shield. When a coil is plugged in, it is, therefore, completely shielded without the inconvenience of replacing a shield-can after the coil change.

The coil forms are supplied with the standard NATIONAL 6-prong coil base, which makes possible the interchangeable use of band spread and regular type coils.

The two charts on this page show the range of all standard coils of both the band spread and general coverage types. When used with the band spread coils, the "FB-7" makes an ideal amateur type receiver. Used with the general coverage coils, it makes a splendid short wave broadcast receiver, which, due to its 59 output tube, high sensitivity and high selectivity, gives unusually fine performance in the reception of foreign programs.

Catalog No.	Range
AB 20	20 Meter Band Spread
AB 40	40 Meter Band Spread
AB 80	80 Meter Band Spread
AB 160	160 Meter Band Spread
FB A	19500 to 11400 Kc
FB B	11700 to 7000 Kc
FB C	7300 to 4000 Kc
FB D	4200 to 2400 Kc
FB E	2500 to 1500 Kc

The list price of coils for all ranges is \$10.00 per pair. Unwound coil forms, complete with trimmer and coil handle are available at a list price of \$3.65 each, and designated by the Catalog Symbol XR-39.

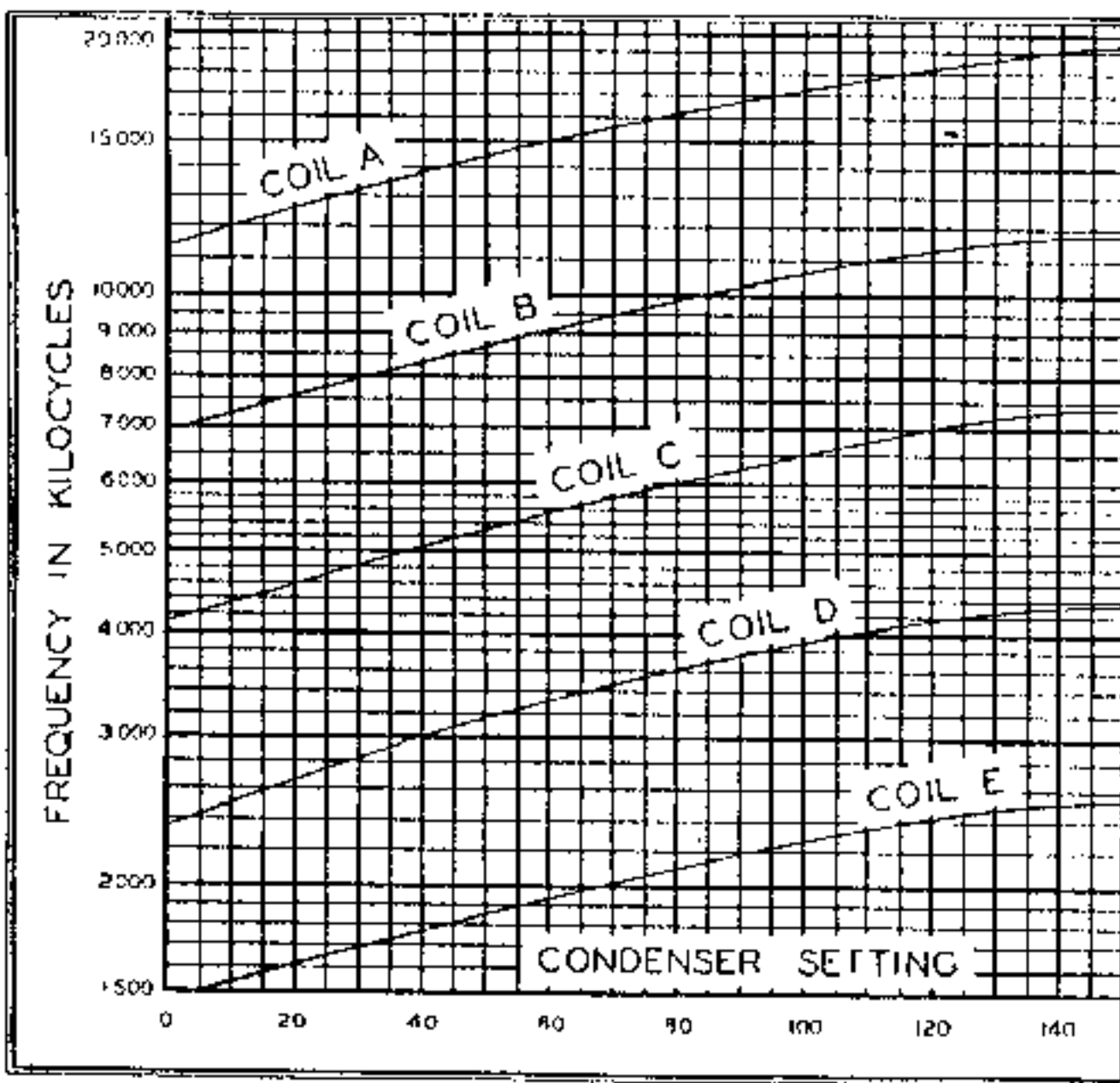
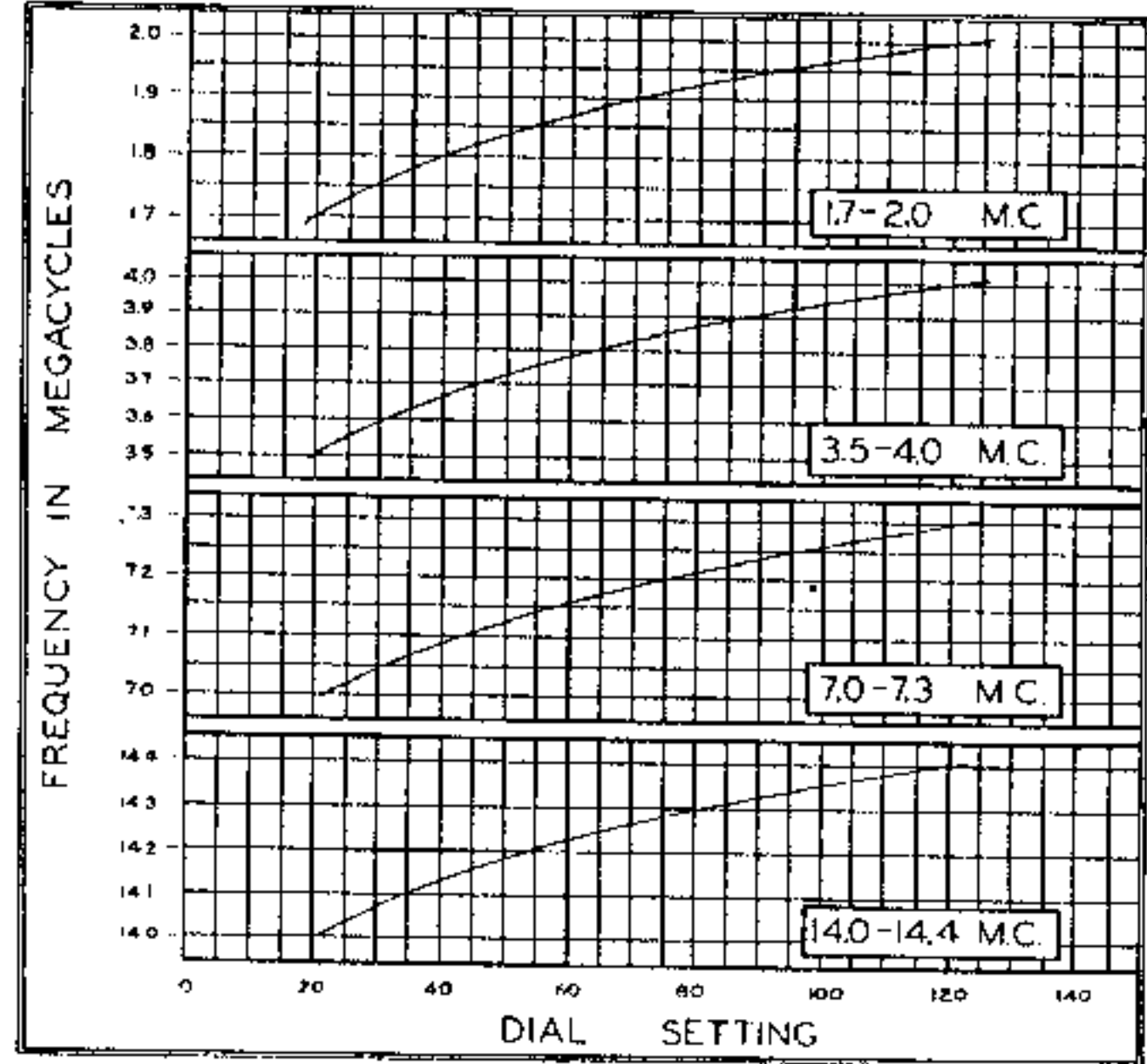

NATIONAL POWER UNITS

The "FB-7" is designed so that it may be operated directly from any one of several NATIONAL power units, or, if desired, from filament transformer and B-batteries. Using 180 volts B, the total drain is 40 milliamperes. The Heater circuit requires 9.5 amperes at 2.5 volts.

The B-voltage employed may be of any value between 180 and 250 volts without affecting the performance of the receiver in any way whatever except for the amount of undistorted power output. For this reason the use of the No. 5887 power unit is recommended, for amateur communication, or, if already available, the No. 5880 power unit may be used. The 5880 differs from the 5887 in that it employs a much higher degree of hum filtration, necessary because of its original design for use with the SW-3 regenerative detector type receiver. The circuit of the "FB-7" does not require such complete power supply filtration and the lower priced No. 5887 is quite adequate.

For short wave broadcast reception, where a high degree of undistorted power output is desirable, a higher plate voltage is recommended than that supplied by either the No. 5887 or the No. 5880. Such a power unit is available in the No. 5897, which furnishes voltages sufficient to drive the type 59 power output pentode in the "FB-7" at full rating.

All of the power units employ, of course, R. F. filters for the elimination of tunable hum, and embody the other exclusive features that are well known to users of NATIONAL power equipment.

Catalog No.	Description	List Price
5887 AB	Special for FB-7 115V. --- 60 Cycles (less tube)	\$24.50
5897 AB	High voltage for operation of '59 tube at full rating. 115V. --- 60 Cycles (less tube)	\$34.50

Above Packs available for other voltage and frequency inputs on special order. Write for prices

R C A LICENSED



NATIONAL COMPANY, INC.
ENGINEERS & MANUFACTURERS
61 SHERMAN ST., MALDEN, MASS.

PRINTED IN U. S. A.
30M 3-33-R