

A 69

AWA MF22 CD-18805A-B

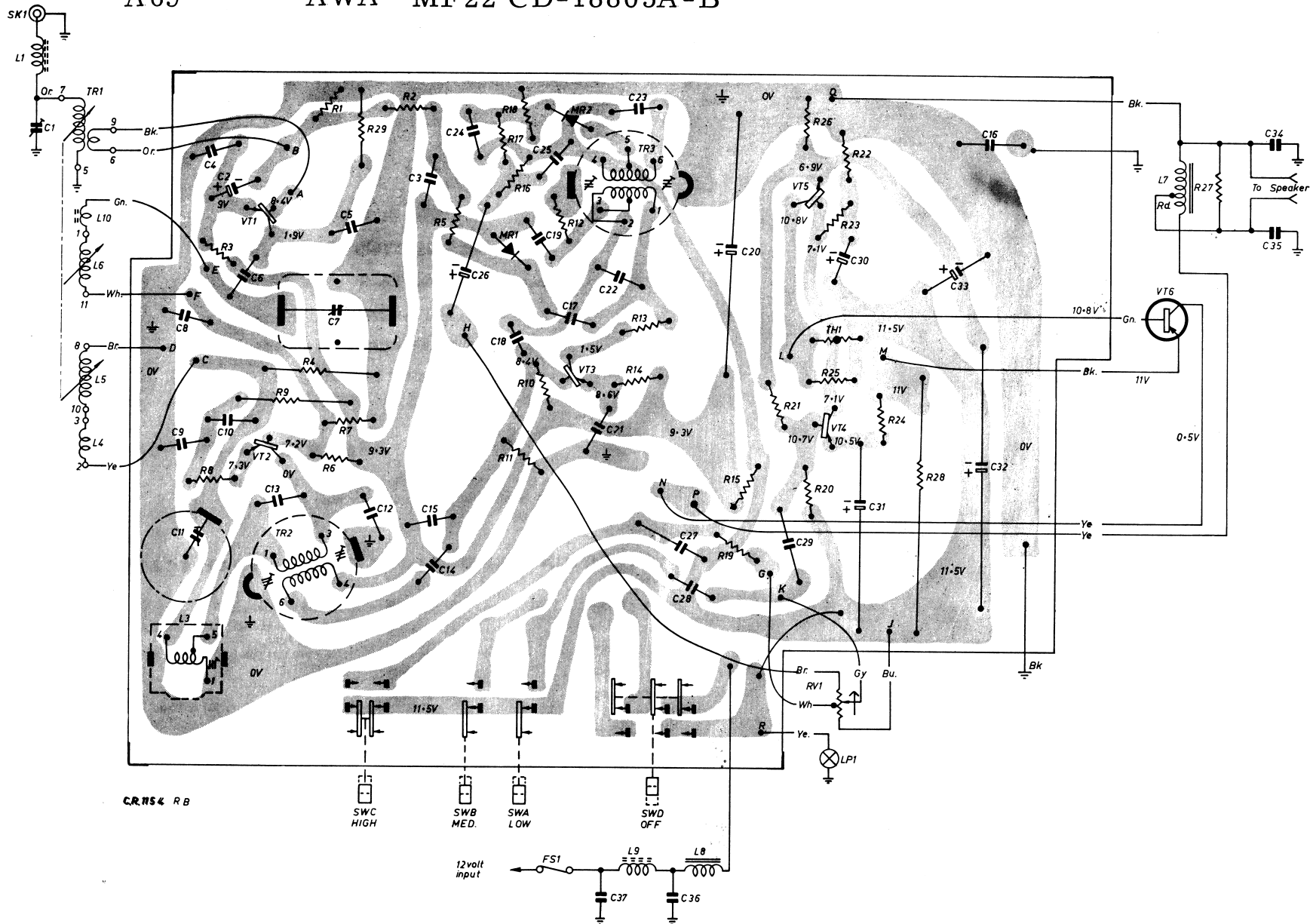

Notes: The diagram represents the view from the wiring side of the printed board.

All voltages shown are positive with respect to the chassis earth and are measured with no signal input and volume maximum clockwise using a 20,000 ohm/volt meter.

FORD CORTINA MANUALLY TUNED CAR RADIO — CD-18805-B (MF22)

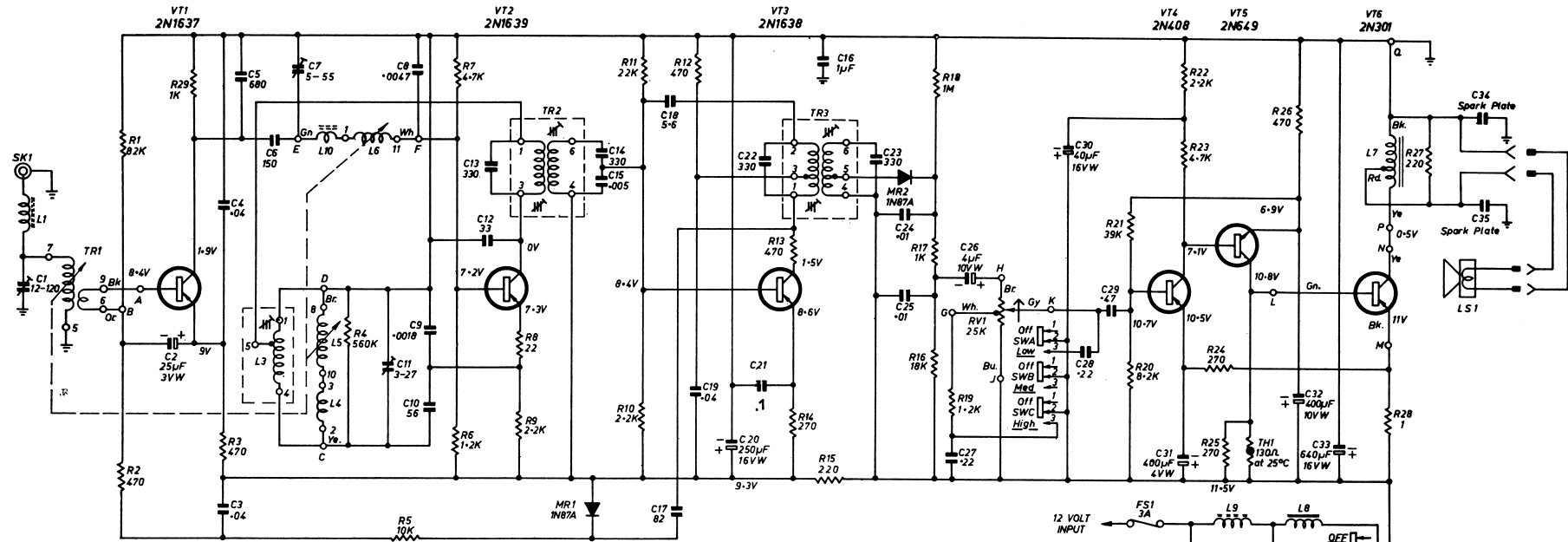

BASE CONNECTIONS

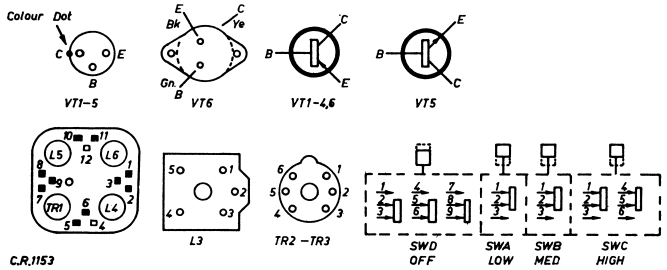

NOTES: Arrow on potentiometer indicates direction of clockwise rotation.
 Voltages measured with 20,000 ohm/volt meter with no signal input.