

# ASTOR Model MD-C4D

A51

AT 17

2N412

2N410-E

2N410-B

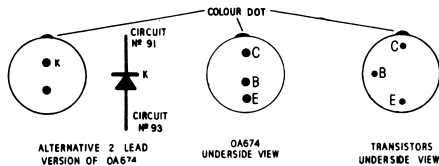
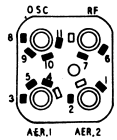
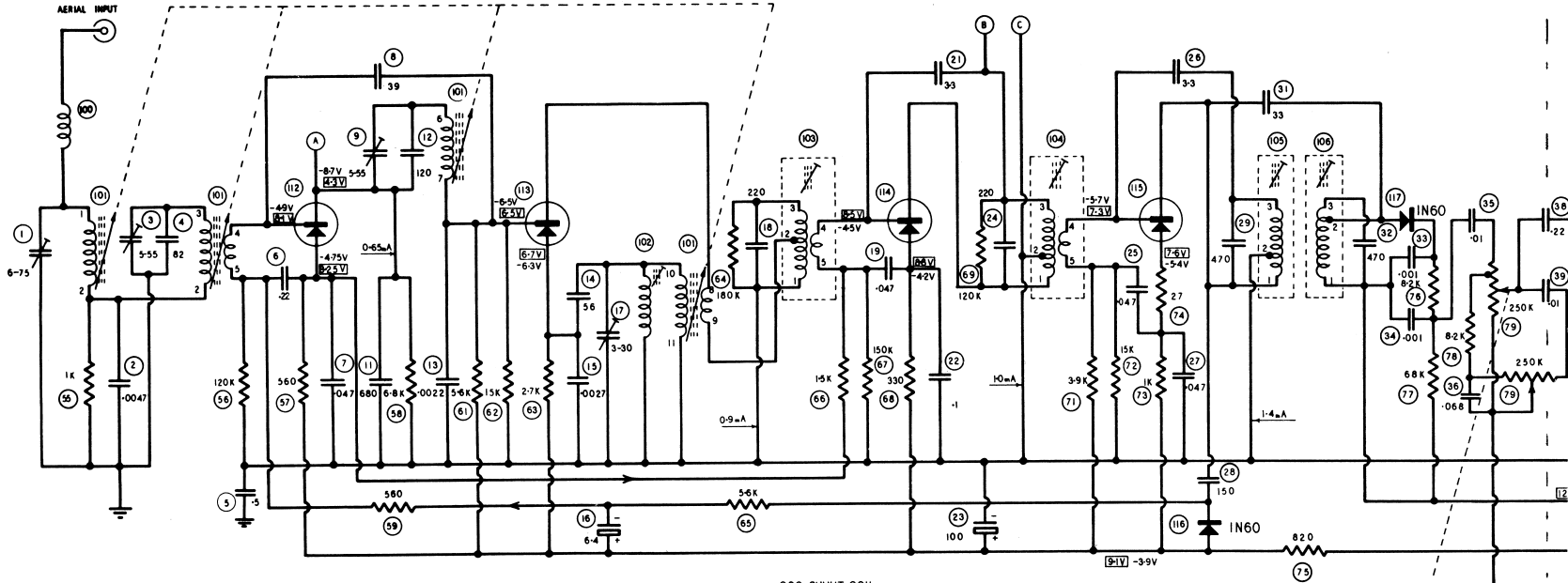

OSC SHUNT COIL  
& I.F. TRANSFORMER  
UNDERSIDE VIEW

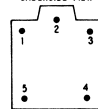

I.F. 455Kc/s

VOLTAGE READINGS IN BOXES REFER TO NEGATIVE CHASSIS CONDITIONS.  
ALL VOLTAGES MEASURED BETWEEN POINTS INDICATED AND CHASSIS WITH A D.C. VACUUM  
TUBE VOLTMETER. NO INPUT SIGNAL.

NUMBERS ASSIGNED TO TERMINALS OF COILS AND TRANSFORMERS ARE TO FACILITATE  
CIRCUIT TRACING OR COMPONENT REPLACEMENT AND MAY NOT BE FOUND ON THE UNIT.

IMPORTANT:- REFER TO SERVICE DATA MD-C4D-1 FOR INSTRUCTIONS BEFORE ADJUSTING  
COLLECTOR CURRENT OF AC12B

WARNING: POLARITY PLUG MUST BE CORRECTLY INSERTED ONTO POLARITY PINS BEFORE  
RECEIVER IS CONNECTED TO BATTERY.

**MODEL MD-C4D**

MANUAL TUNING

POSITIVE OR NEGATIVE TO CHASSIS

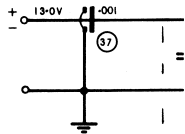

# ASTOR Model MD-C4D

2N406

2N591

AC128

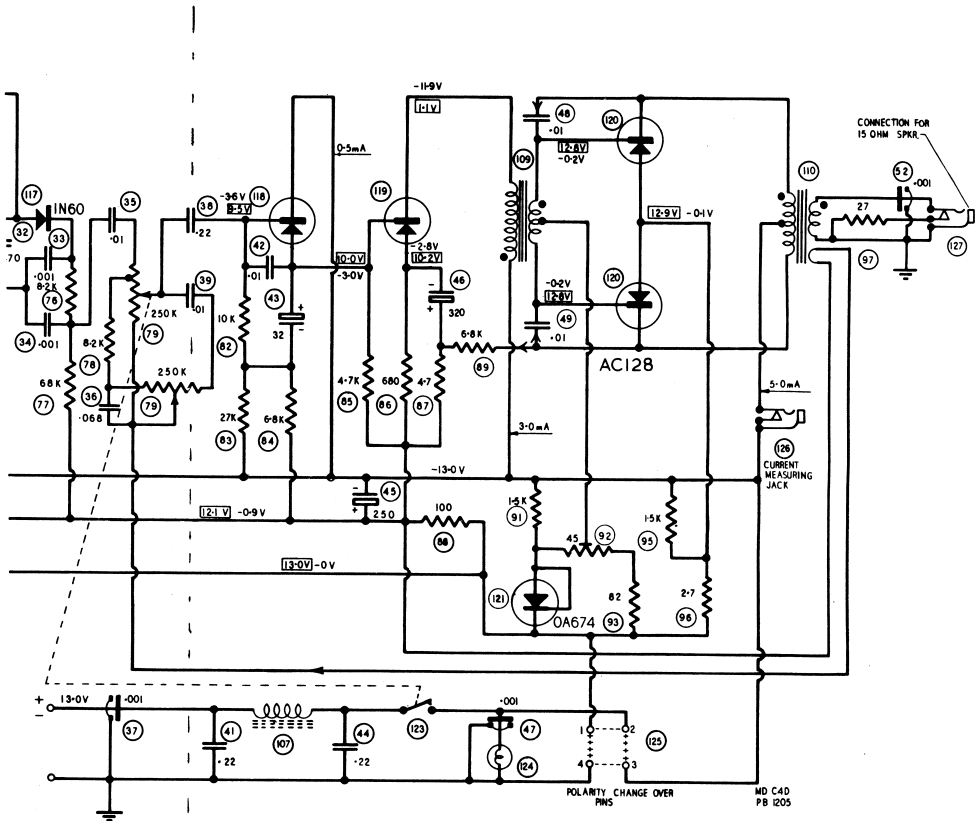

ALIGNMENT PROCEDUREEQUIPMENT

Signal Generator - modulated 400 cps  
 Output Meter - 15 Ohms Impedance  
 Generator Series Capacitor - .1mF Part No. 4006-005-03. for IF alignment  
 IF Attenuator - Part No. 4121-014-01  
 Dummy Aerial - 65pF Part No. 4121-009-01  
 Alignment Tools

- (a) Chisel Point Type: Part No. 4121-005-01 for trimmer capacitor adjustment
- (b) Flat Metal Blade Type: Part No. 4121-001-01 for I. F. T. and Osc. shunt coil adjustment.
- (c) Tuning Unit Iron Core Adjustor: Part No. 4121-008-01
- (d) Alignment Gauge: Part No. 4121-023-02 for tuner 1000 Kc/s position.  
 Collector Current Meter Connection - Jack plug Part No. 7171-015-02

CONDITIONS

Remove screws and slide can off receiver.

Volume Control - maximum (fully clockwise)  
 Tone Control - maximum treble (fully clockwise)  
 Output Level - 50 milliwatts, output meter reading with speaker voice coil disconnected.  
 Output Meter - Socket adjacent to receiver battery lead entry. Use plug Part No. 7171-015-02  
 Connection - or use original plug and leads from speaker.

Supply Voltage and Connection 13. OV DC. Connect appropriate supply lead to chassis and other lead to fuse holder lead. Check polarity plug and set plug to suit supply source

INTERMEDIATE FREQUENCY TRANSFORMER ALIGNMENT

Turn tuning control until perm. tuner iron cores are out of the coil formers. Insert .1mF capacitor in series with generator "hot" lead.

Oper. No.	Generator Connection	Generator Frequency	Instructions
1.	To test pin "B" (term 3 of 2nd I. F. T.)	455 Kc/s	Adjust iron core of 4th IF trans for max. output
2.	as Oper. 1.	455 Kc/s	Adjust iron core of 3rd IF. trans. for max. output
3.	Repeat operations 1 & 2		
4.	To Terminal 8. on tuner (mixer /osc. collector)	455 Kc/s	Adjust iron core of 2nd IF trans for max. output
5.	To test pin "A" (RF. amp. collector)	455 Kc/s	Adjust iron core of 1st IF trans for max. output

BROADCAST ALIGNMENT

If the receiver logging is satisfactory the signal circuits may be aligned as detailed.

- Connect IF. attenuator to test pins "B" and "C" (resistor to pin "C")
- Aerial Lead-in Socket - 65 pF. dummy in series  
 1000 Kc/s  
 Tune receiver to generator frequency  
 Adjust RF. and both aerial trimmer capacitors for max. output.

BROADCAST ALIGNMENT

When iron cores or tuning unit coil assy. have been replaced or if station logging is outside limits.

Oper. No.	Generator Connection	Generator Frequency	Instructions
1.	Connect IF. attenuator to test pins "B" and "C" (resistor to pin "C").		
2.	Turn perm. tuner against high frequency end of travel stop. <b>Set all iron cores so that not less than 3/8" of adjusting shafts protrude forward of front face of core carriage.</b>		
3.	To aerial Lead-in Socket. 65pF. dummy aerial series	1625 Kc/s	Adjust Osc. RF and both Aerial trimmer capacitors for max. output.
4.	Refer diagram. Place the 1000 Kc/s alignment gauge Part No. 4121-023-01 or alternatively a flat piece of metal 0.39" wide between the core carriage and loose collar. Gently turn tuning spindle until gauge is located squarely between collar and carriage.		
5.	As oper. 3.	1000 Kc/s	With tuner set in position detailed, adjust Osc. , RF. and both Aerial iron cores for maximum output.
6.	As oper. 3.	600 Kc/s	Rock tuning control through signal, adjust Osc. shunt coil iron core for max. output.
7.	Turn tuning control to low freq. end of travel (iron cores full in). Tune signal generator to receiver. The low freq. tuning limit should be between 510 and 528 Kc/s.		
8.	Repeat operations 4 and 5.		
9.	Align dial pointer.		

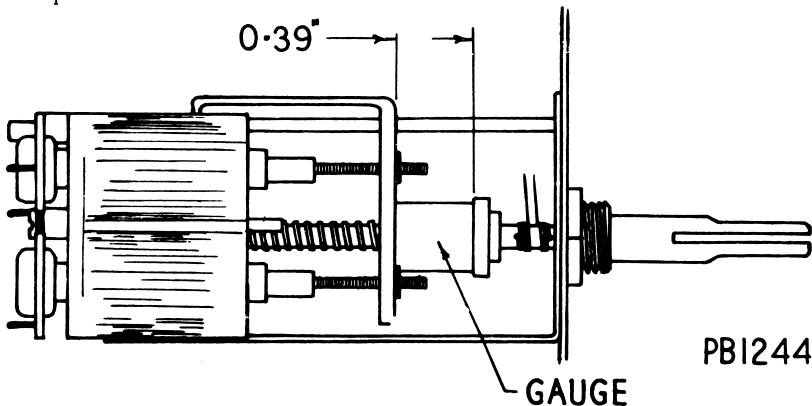

SETTING OF DIAL POINTER

Disconnect the IF attenuator.

Disconnect the generator cable from dummy aerial then connect 20 ft. , of aerial wire to the dummy aerial terminal.

Slip dial pointer carriage assy. along guide rail until the centre of the pointer coincides with centre of the tuned station call sign.

Check dial logging and if necessary readjust pointer carriage.

OPERATION OF OUTPUT TRANSISTORS AS MATCHED PAIRS

The type AC128 transistors are operated in matched pairs, designated 2-AC128; replacements MUST be made accordingly and not as single units.

The transistor pairs are identified by a letter symbol stamped on to the top of transistor housing. Transistors which have different batch symbols must not be operated together.

MEASUREMENT AND ADJUSTMENT OF COLLECTOR CURRENT

EQUIPMENT	Current Meter: 0-1 Amp. DC Leads terminated with Jack Plug, Part No: 7171-015-02; positive terminal lead to tip contact. Supply Source: 13V DC
CONDITIONS	Connect receiver to 13V DC. Check polarity plug. Set Volume control at minimum. No signal applied to aerial input. Connect speaker to receiver socket adjacent to battery lead entry Connect meter to receiver socket located on the rear and covered by protector insert.

1. Switch receiver "ON" and allow to stabilize for at least five minutes.
2. Carefully adjust bias rheostat to obtain a reading of 5mA.

- NOTE. 1. It is essential that the supply voltage is maintained at 13.0V when measuring current.
- NOTE. 2. After a long period of operation it will be noted the collector current will decrease slightly. This is normal and is caused by the warming of the positive temperature co-efficient components.
- NOTE. 3. No further adjustment of the bias should be necessary unless output transistors are replaced.

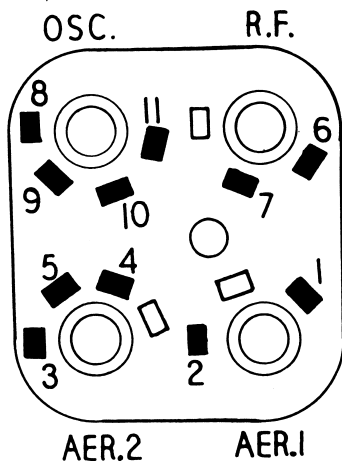

## MANUAL TUNER COIL DESIGNATIONS.

The aerial coil and aerial transformer shown on tuner connection diagram as AER. 2. and AER. 1. will be designated and shown as AER. 1. and AER. 2. on all future circuits. Diagram at left shows standard designation. The connections of the tuner to the receiver circuit remain unchanged.