

BOX 107 P.O. CARINGBAH N.S.W. 524-0444

PLEASE CIRCULATE TO YOUR SERVICE DEPARTMENT

RADIO DATA, MODELS 11-112, 11-120

DESCRIPTION

These models, which are identical except for speaker complement and Record Playing equipment, are solid state Record Players, operated from 240V 50Hz mains.

NOTE: The Record Changer Start Control applies power to the changer motor and to the amplifier and the latter, being fully solid state, functions immediately. At the end of the (last) record the Start Control returns from MAN or ON/REJ to OFF in the normal way and this action cuts off power to the amplifier and the motor.



Model 11-112



Model 11-120

- | | | |
|----------------------------|--|--------------------------------|
| RECORD PLAYER: | MODEL 11-112 | MODEL 11-120 |
| | BSR UA15 – ID OR BSR UA 35 | BSR UA15 – ID OR BSR UA15SS5G. |
| CARTRIDGE: | TYPE C1 HIGH CAPACITANCE CERAMIC. | |
| STYLUS: | TYPE ST4 DIAMOND L.P. PRESSURE, 6 Gms. | |
| SPEAKERS: | MODEL 11-112 | MODEL 11-120 |
| | 2 x 9" x 6" MAGNAVOX 96S1, 8Ω | 2 x MAGNAVOX 6", 6 PIX, 8Ω |
| CAUTION: | If adding extra extension speakers, do NOT use a makeshift speaker impedance totalling less than 6Ω otherwise transistor damage may result. | |
| MAINS SUPPLY: | Nominal 240V 50Hz. If operating from a nominal 250V supply, add a 180 Ω 5W, resistor in parallel with R18 (220Ω 5W). For operation on 40 Hz, change motor. | |
| AUDIO POWER OUTPUT: | 2.5W per channel, Music Power, RMS Power 1.9W at 1KHz, distortion 10% if both channels are driven simultaneously to full output. | |
| CHASSIS REMOVAL: | Remove two self-evident screws securing the amplifier escutcheon to the inside wall of the record changer well. Lift out amplifier, unplugging connection to power supply unit if desired. | |
| CHANGER REMOVAL: | Remove four self-evident screws securing the motor board on which the turntable is mounted. Lift out motor board and changer complete, disconnecting appropriate leads as desired. | |

MODELS 11-112 & 11-120.

ISSUE 2 1-12-68

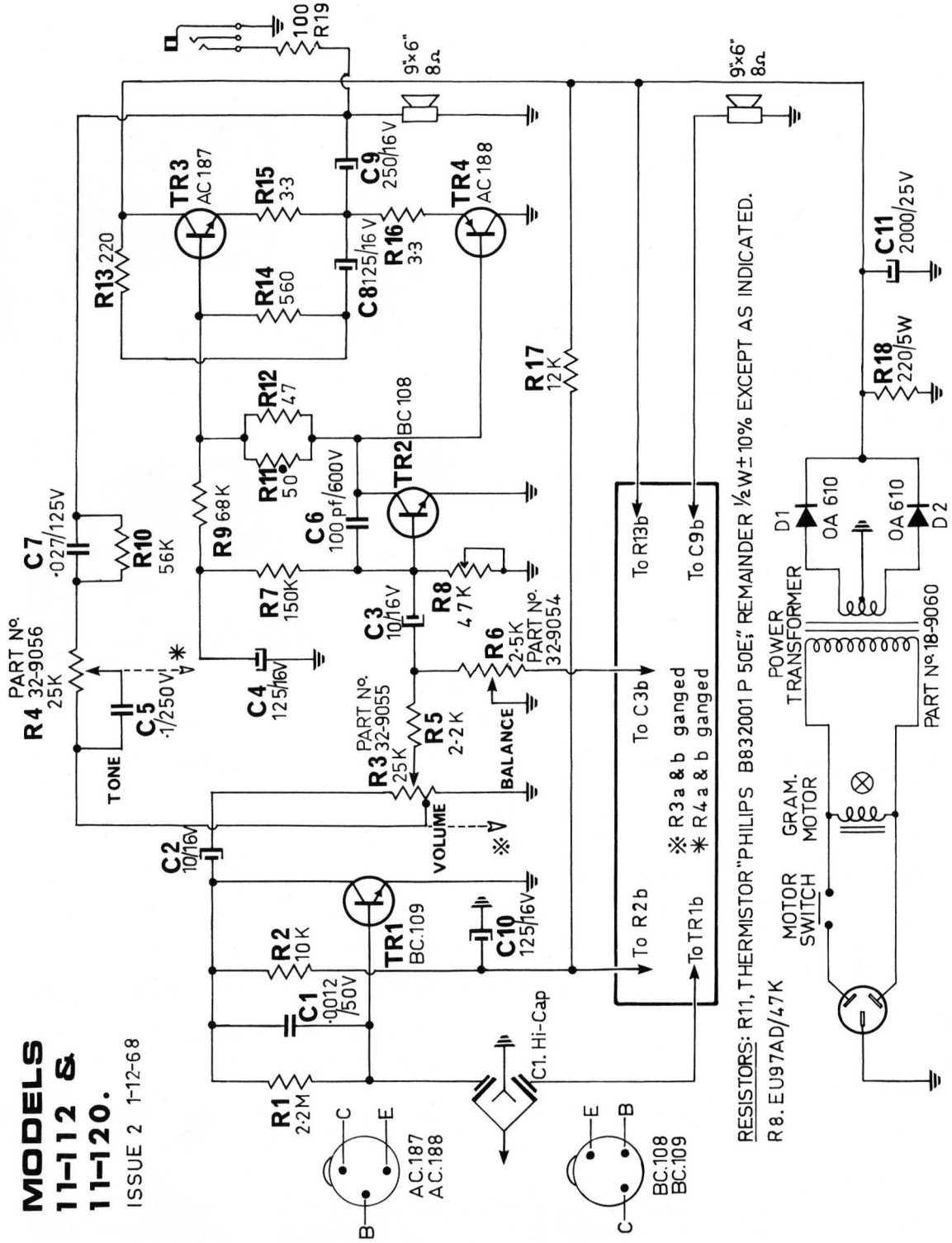

RESISTORS: R11, THERMISTOR "PHILIPS B832001 P 50E;" REMAINDER 1/2 W ± 10% EXCEPT AS INDICATED.

R8. EU97AD/47K

PARTS LIST: Electrical.

Resistors: See circuit diagram.
Capacitors: See circuit diagram.

PARTS LIST. Mechanical

- 11-112 11-120.
- Dial Backing Plate 16-9046
- Escutcheon 16-9048
- Plug Cover 20-8318
- Cover Panel 20-9061
- Knob, Control 90-9363
- Speaker Plug 691-10-1
- Speaker Socket 733-23-3
- Captive Nut SNU-1561-17-0
- Earphone Jack MOJ BISR
- L.D. Trim 16-9059
- L.D. Stay Assy. 90-8322B
- Cabinet 30-9053
- Metal Cal-Tone Arm 16-9757
- Lid Cover 20-9074
- Foot 20-7106
- Rubber Buffer Brown 40-74

- 11-120
- Speaker Enclosure 30-9066
- Shelf 30-9068
- Table 46-9065

- 11-112
- Speaker Enclosure 30-9052