



DIVISION OF ELECTRONIC INDUSTRIES LTD.
126-130 GRANT STREET, SOUTH MELBOURNE, S.C.A.

TECHNICAL BULLETIN

MODEL "GPS"

5 VALVE SUPERHETERODYNE UNIVERSAL PORTABLE RECEIVER.
WITH BATTERY REACTIVATION

FOR OPERATION FROM:

195-260 Volt 40-60 Cycle A.C. electric supply mains.
195-260 Volt D.C. electric supply mains or
9 volts 'A' battery and
90 volts 'B' battery. (Two 45 volt 'B' batteries connected in series.)

POWER CONSUMPTION:

Battery operation:- 50Ma. 'A' Battery.
11Ma. 'B' Battery.
A.C. operation:- 90Ma. 230 volts 50 cycle A.C. input to receiver. Mains resistor adjustable clip adjusted to 8.7 volts D.C. across valve filament circuit.
D.C. operation:- 65Ma. 230 volts D.C. input to receiver. Mains resistor adjustable clip adjusted to 8.7 volts D.C. across valve filament circuit.

TUNING RANGE:

535 to 1620 Kilocycles. 560.7 to 185.18 Metres.

POWER OUTPUT:

250 milliwatts (max.).
100 milliwatts (undistorted).

THIS BULLETIN CONTAINS:-

Technical Data.
Alignment Procedure.
Circuit Diagram.

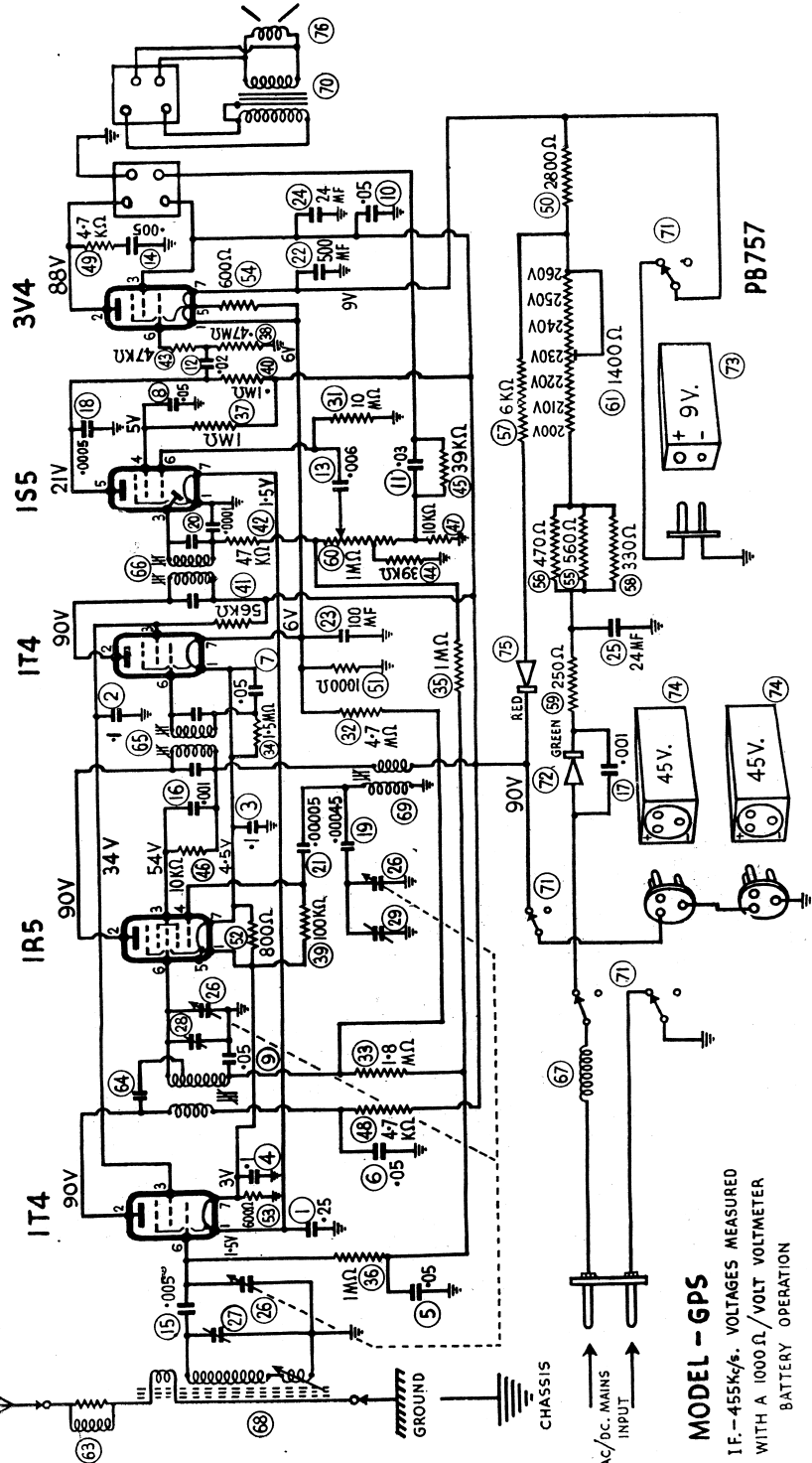
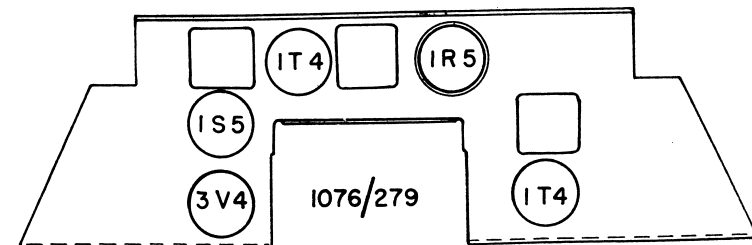

MODEL - GPS

IF - 455Kc/s. VOLTAGES MEASURED
WITH A 1000Ω/VOLT VOLTMETER
BATTERY OPERATION

CHASSIS

AC/DC MAINS INPUT

P8757



TECHNICAL BULLETIN

“MODEL GPS” (2nd Version)

5 VALVE SUPERHETERODYNE UNIVERSAL PORTABLE RECEIVER

Function Switch Positions

1. Internal Battery Operation.
2. Receiver "Ofr."
3. AC. or DC. Mains Operation.
4. Battery Reactivation.

FOR OPERATION FROM:

- 195-260 Volt 40-60 Cycle A.C. electric supply mains.
- 195-260 Volt D.C. electric supply mains or
- 9 volts 'A' battery and
- 90 volts 'B' battery. (Two 45 volt 'B' batteries connected in series.)

POWER CONSUMPTION:

- Battery operation:- 50mA. 'A' Battery.
11mA. 'B' Battery.
- A.C. operation:- 100mA. 230 volts 50 cycle A.C. input to receiver. Mains resistor adjustable clip adjusted to 230V. position
- D.C. operation:- 60mA. 230 volts D.C. input to receiver. Mains resistor adjustable clip adjusted to 230V. position.

TUNING RANGE:

- 535 to 1620 Kilocycles. 560.7 to 185.18 Metres.

POWER OUTPUT:

- 250 milliwatts (max.).
- 100 milliwatts (undistorted).

THIS BULLETIN CONTAINS:-

1. Technical Data.
2. Alignment Procedure.
3. Circuit Diagram.

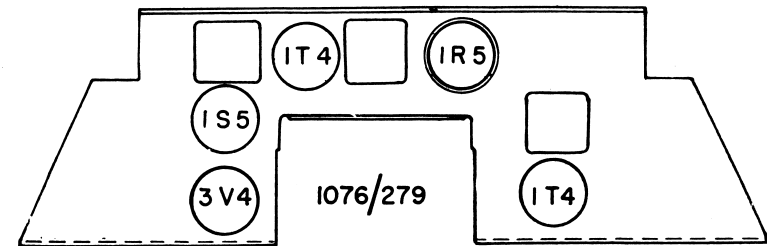
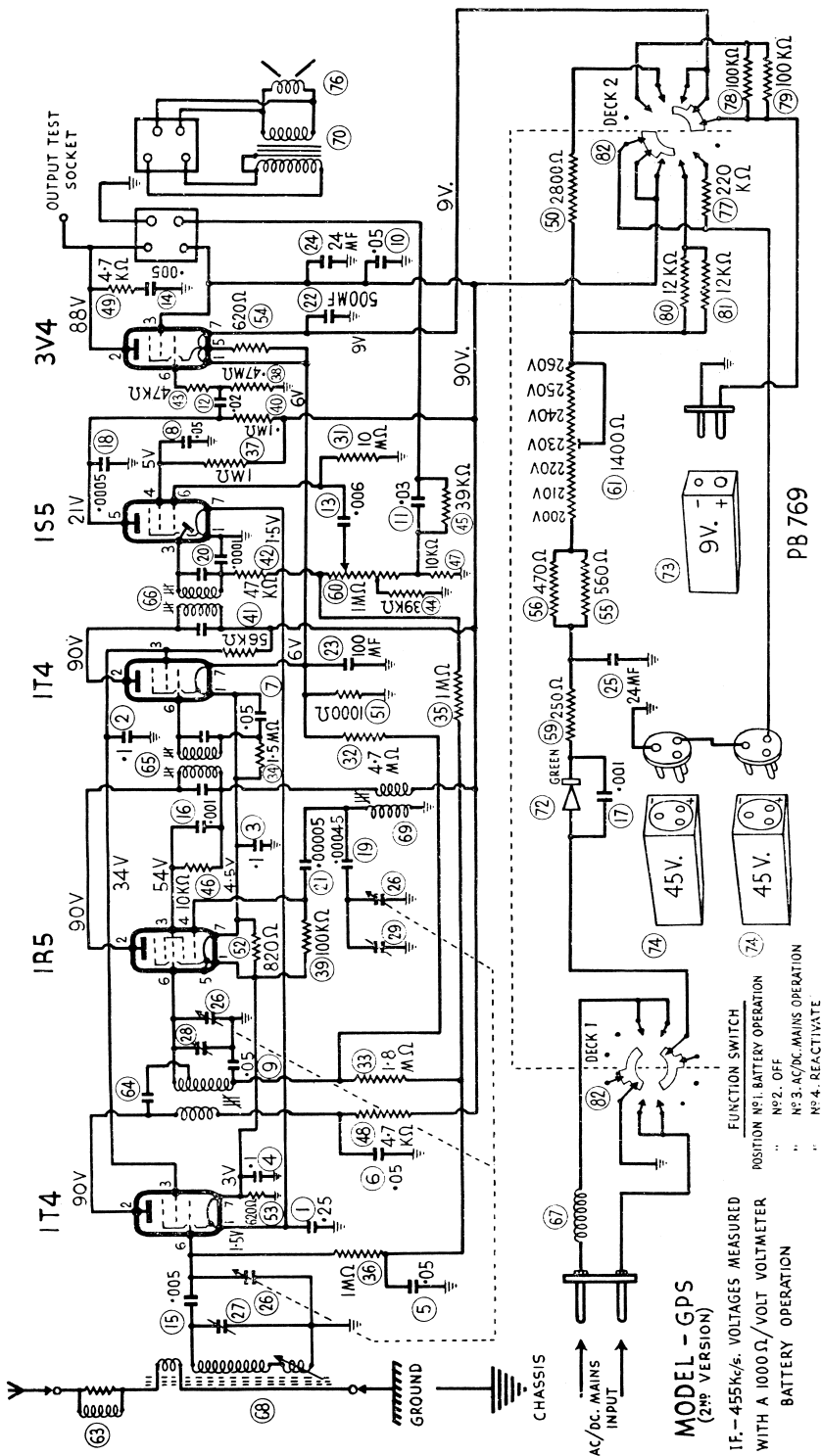

ALIGNMENT INSTRUCTIONS

EQUIPMENT	ALIGNMENT CONDITIONS
Signal Generator:	Load Impedance: 10,000 ohms.
Output Meter:	Output Level: 25 milliwatts.
Safety Lamp: 230 volt 40 watt incandescent lamp.	Volume Control: Max. vol. (fully clockwise).
Mica Capacitor: 0.01MF (part No. PC145) for I.F.T. Alignment.	'A' Battery: 9 volts.
Alignment Template: Part No. PB758	'B' Battery: 90 volts (two 45 volt 'B' batteries connected in series).
Alignment Tools: Part No. PM581 and M195.	Intermediate Freq.: 455 Kc/s.

TO REMOVE CHASSIS FROM CABINET: Turn the receiver switch marked "BATT"- "OFF"- "MAINS"- "REACT" to the "OFF" position and withdraw the AC/DC mains lead plug from the small socket at the rear of the receiver cabinet.

Remove the dial pointer centre tuning push-on knob by pulling it straight off the tuning control spindle. Remove volume control and ON/OFF switch knobs by loosening off the small grub screws in the knobs. (The first production run had push-on type knobs and no grub screws). Unscrew and remove two screws through top ridge of cabinet, then from top of cabinet prise rear section of cabinet away from front section. Disconnect from speaker the lead connecting speaker frame to chassis.

The chassis is held in the cabinet by a $\frac{3}{4}$ " x 5/32" Whit. screw and nut at each end of the chassis. Loosen off these two screws, withdraw speaker lead plug from socket on chassis then lift the chassis out of the cabinet.

Opera- tion.	Generator connection.	Generator Frequency.	Dummy Antenna.	Instructions.
--------------	-----------------------	----------------------	----------------	---------------

- The receiver may be aligned when operating it from batteries or from the A.C. or D.C. mains. When operating it from the A.C. or D.C. mains apply the safety lamp between the receiver chassis and ground to make sure the chassis is not above earth potential; if it is, reverse the receiver plug in the power point socket.
- The wire connecting the speaker frame to the receiver chassis which was disconnected when removing the chassis from the cabinet is to be reconnected during alignment of the receiver.
- To control grid of IT4 IF valve (pin No. 6) 455 Kc/s. 0.01MF mica capacitor in series with generator. Leave grid wire attached to valve socket. Peak 2nd IF trans. pri. and sec. for max. output.
- To control grid of IR5 valve (pin No. 6). 455 Kc/s. 0.01MF mica capacitor in series with generator. Leave grid wire attached to valve socket. Turn gang plates fully out of mesh. Peak 1st IF trans. pri. and sec. for max. output.
- Repeat operations No. 3 and 4.
- ALIGNMENT TEMPLATE: A cardboard alignment template part No. PB 758 is available from the factory. The template may be made by using the diagram on page 12 and fastening it to a piece of cardboard.
- DIAL POINTER SETTING: Fit alignment jig to chassis, then fit push-on pointer-tuning knob to tuning spindle. Fully mesh cond. gang plates and set centre of dial pointer on centre of end of travel spot on template near 540 Kc/s.
- To inject a signal into the receiver rod aerial connect to the active terminal of the signal generator approx. 2 ft. of aerial wire then fashion the wire into a vertical position.

- Place receiver chassis in a horizontal position with the rod aerial uppermost and so that the fixed primary winding end of the rod aerial points to the 2 ft. of aerial wire attached to the generator and so that the fixed primary winding is not closer than 2 ft. from the 2 ft. of aerial wire.
- Refer para. 600 Kc/s. 8 and 9 Turn cond. gang and dial pointer until centre of dial pointer is on 600 Kc/s. mark on dial template. Leave the cond. gang and dial pointer set in this position and peak osc. coil ind. trim. (iron core) and then from the base of the RF trans. peak the RF. trans. ind. trim. (iron core). Also peak for max. output the secondary trimmer coil on the ferrite rod by sliding the trimmer coil along the aerial rod.
- Refer para. 1400 Kc/s. 8 and 9 Turn cond. gang and dial pointer until centre of pointer is on 1400 Kc/s. dial mark on template. Adjust osc. coil trim. cond. for logging and peak RF trans. trim. cond. then rod aerial trimmer cond. for max. output.
- Refer para. 600 Kc/s. 8 and 9 Turn cond. gang and dial pointer until centre of dial pointer is on 600 Kc/s. mark on dial template. Leave the gang and dial pointer set in this position. Repeat osc. coil ind. trim. (iron core) RF. trans. ind. trim. (iron core) and the secondary trim. coil on the ferrite rod. Do not rock the gang to and fro through the signal while adjusting the trimmers or move the dial pointer off 600 Kc/s. dial template mark until after the ind. trimmer of these three coils have been peaked for max. output.
- Refer para. 1400 Kc/s. 8 and 9 Turn cond. gang and dial pointer until centre of dial pointer is on 1400 Kc/s. mark on dial template. Adjust osc. coil trim. cond. for logging and peak RF trans. and ferrite rod aerial trimmer conds. for max. output.
- Refit receiver chassis to cabinet in the exact reverse procedure to removing it. Make sure that the grub screws in the control knobs are tightened securely.

TUNING RANGE AFTER ALIGNMENT, 535 to 1620 Kc/s.

ALIGNMENT INSTRUCTIONS

EQUIPMENT

Signal Generator:
Output Meter:
Safety Lamp: 230 volt 40 watt
incandescent lamp.
Mica Capacitor: 0.01MF (part No. PC145)
for I.F.T. Alignment.

ALIGNMENT CONDITIONS

Load Impedance: 10,000 ohms.
Output Level: 25 milliwatts.
Volume Control: Max. vol. (fully
clockwise).
'A' Battery: 9 volts.
'B' Battery: 90 volts (two 45 volt
'B' batteries connected in
series).
Intermediate Freq.: 455 Kc/s.

Alignment Tools: Part No. PM581 and M195.

TO REMOVE CHASSIS FROM CABINET: Turn receiver ON/OFF switch to the
'OFF' position and withdraw the AC/DC mains lead plug from the small socket
at the rear of the receiver cabinet.

Remove the dial pointer centre tuning push-on knob by pulling it straight
off the tuning control spindle. Remove volume control and ON/OFF switch knobs
by loosening off the small grub screws in the knobs. (The first production run had
push-on type knobs and no grub screws). Unscrew and remove two screws through
top ridge of cabinet, then from top of cabinet prise rear section of cabinet
away from front section. Disconnect from speaker the lead connecting speaker
frame to chassis.

The chassis is held in the cabinet by a $\frac{3}{4}$ " x $\frac{5}{32}$ " Whit. screw and nut at
each end of the chassis. Loosen off these two screws, withdraw speaker lead plug
from socket on chassis then lift the chassis out of the cabinet.

Opera- tion.	Generator connection.	Generator Frequency.	Dummy Antenna.	Instructions.
--------------	-----------------------	----------------------	----------------	---------------

- The receiver may be aligned when operating it from batteries or from the
A.C. or D.C. mains. When operating it from the A.C. or D.C. mains apply
the safety lamp between the receiver chassis and ground to make sure the
chassis is not above earth potential; if it is, reverse the receiver plug
in the power point/light socket.
- The wire connecting the speaker frame to the receiver chassis which was
disconnected when removing the chassis from the cabinet is to be reconnected
during alignment of the receiver.
- To control 455 Kc/s. 0.01MF mica capacitor Leave grid wire attached to valve
grid of IT4 socket. Peak 2nd IF trans. pri. and
IF valve in series sec. for max. output.
(pin No. 6) with generator.
- To control 455 Kc/s. 0.01MF mica capacitor Leave grid wire attached to valve
grid of IR5 socket. Turn gang plates fully out
valve (pin in series of mesh. Peak 1st IF trans. pri. and
No. 6). with sec. for max. output.
generator.
- Repeat operations No. 3 and 4.
- ALIGNMENT TEMPLATE: Supplied with each 'GPS' Service Bulletin is a cardboard
alignment template. Should this template be lost another one may be made
by using the diagram on page 12 and fastening it to a piece of cardboard.
- DIAL POINTER SETTING: Fit alignment jig to chassis, then fit push-on pointer-
tuning knob to tuning spindle. Fully mesh cond. gang plates and set centre
of dial pointer on centre of end of travel spot on template near 540 Kc/s.
- To inject a signal into the receiver rod aerial connect to the active terminal
of the signal generator approx. 2 ft. of aerial wire then fashion the
wire into a vertical position.

- Place receiver chassis in a horizontal position with the rod aerial upper-
most and so that the fixed primary winding end of the rod aerial points to
the 2 ft. of aerial wire attached to the generator and so that the fixed
primary winding is not closer than 2 ft. from the 2 ft. of aerial wire.
- Refer para. 600 Kc/s. 8 and 9 Turn cond. gang and dial pointer until
centre of dial pointer is on 600 Kc/s.
mark on dial template. Leave the cond.
gang and dial pointer set in this
position and peak osc. coil ind. trim.
(iron core) and then from the base of
the RF trans. peak the RF. trans. ind.
trim. (iron core). Also peak for max.
output the secondary trimmer coil on
the ferrite rod by sliding the trimmer
coil along the aerial rod.
- Refer para. 1400 Kc/s. 8 and 9 Turn cond. gang and dial pointer until
centre of pointer is on 1400 Kc/s. dial
mark on template. Adjust osc. coil trim.
cond. for logging and peak RF trans.
trim. cond. then rod aerial trimmer
cond. for max. output.
- Refer para. 600 Kc/s. 8 and 9 Turn cond. gang and dial pointer until
centre of dial pointer is on 600 Kc/s.
mark on dial template. Leave the gang
and dial pointer set in this position.
Repeat osc. coil ind. trim. (iron core)
RF. trans. ind. trim. (iron core) and
the secondary trim. coil on the ferrite
rod. Do not rock the gang to and fro
through the signal while adjusting the
trimmers or move the dial pointer off
600 Kc/s. dial template mark until
after the ind. trimmer of these three
coils have been peaked for max.
output.
- Refer para. 1400 Kc/s. 8 and 9 Turn cond. gang and dial pointer until
centre of dial pointer is on 1400
Kc/s. mark on dial template. Adjust
oscl. coil trim. cond. for logging
and peak RF trans. and ferrite rod
aerial trimmer conds. for max. output.
- Refit receiver chassis to cabinet in the exact reverse procedure to removing
it. Make sure that the grub screws in the control knobs are tightened
securely.

TUNING RANGE AFTER ALIGNMENT, 535 to 1620 Kc/s.