

H E A T H

a subsidiary of  
**DAYSTROM**



COMMUNICATIONS  
RECEIVER  
MODEL W-GC-1A

**OWNER'S MANUAL**

# THE HEATH W-GC-1A COMMUNICATIONS RECEIVER

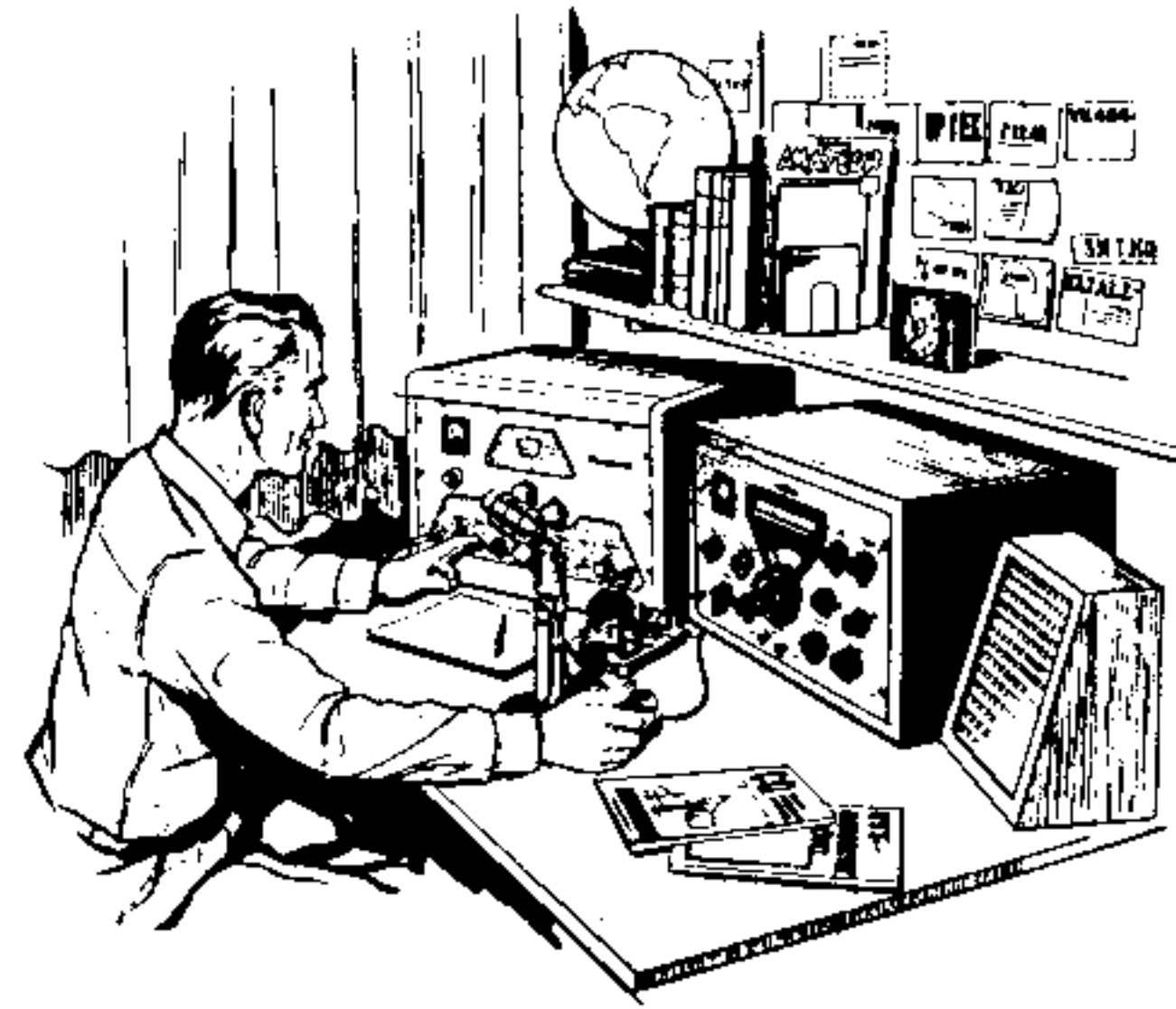

Your new "Mohican" W-GC-1A packs more top quality, professional-design features into its handsome, compact cabinet than any receiver of its class on the market. Selection of standard broadcast band, and five short-wave bands with electrical bandspread, puts you in touch with the further-most corners of the earth, as well as the home town station.

## CONTENTS

Features . . . . .	2
Antenna . . . . .	2
Fixed Station . . . . .	2
Operation . . . . .	3
Tuning . . . . .	4
Specifications . . . . .	5
Replacement Parts . . . . .	6, 7
Warranty . . . . .	8
Schematic . . . . .	Foldin





## FEATURES

**ELECTRICAL BANDSPREAD...** is provided on 5 separately calibrated ham bands and the 11-meter citizens band... giving you pinpoint selection and crisp-clear reception of otherwise jumbled signals.

**IF TRANSFILTERS:** Your W-GC-1A is the first unit of its kind to use the new, rugged, ceramic IF "transfilters," previously available only on military equipment. They never need aligning, assuring peak performance without servicing.

**PORTABLE:** The completely solid-state circuit of your W-GC-1A is powered by 8 standard flashlight batteries for complete portability.

**CONVERTIBLE:** A **HEATHKIT®** Power Converter (XP-2) is available for your Mohican to convert it to 110 V AC operation. The compact unit fits in the space normally occupied by the battery power supply.

HEATH

**LONG-RANGE ANTENNA:** A built-in telescoping 54" whip antenna pulls out of the top of your W-GC-1 case — no need for external connections.

**TOP QUALITY FEATURES...** include such conveniences as: an accurate tuning meter for pinpointing stations; flywheel tuning for easy, fingertip control; an automatic noise limiter circuit; automatic volume control to prevent "blasting" or "fading;" a beat frequency oscillator control for listening to code; an edge-lighted, slide-rule type dial for easy tuning.

## ANTENNA

If you use the W-GC-1A only for receiving purposes, you can use only the built-in collapsible antenna; or for more distant reception, you can connect a long-wire or communications type antenna to the ANTENNA terminal on the rear of the W-GC-1A.

## FIXED STATION

If the W-GC-1A is used as the receiver section of an amateur radio station, it can be operated with the same antenna that is used with your transmitter.

When using this receiver with a transmitter, the muting terminals on the rear of the chassis should be used. These terminals are in the -12 volt supply lead and protect the receiver from overload and possible damage when being used in close proximity to a transmitter.

Using an external switch or a relay, the terminals 1 and 2 of the muting terminal should be open (disconnected) during the transmit period and closed (connected) during the receive period. The jumper wire used in normal operation must be removed for this type of operation.

In using this receiver in close proximity to a transmitter, i.e., as the station receiver, it is desirable to short the antenna terminal to the ground terminal during transmit conditions. Excessive signal in the "front end" of the receiver may cause failure of the RF amplifier transistor.

## OPERATION

**VOLUME:** Advancing the control marked VOLUME from counterclockwise position turns on the power and controls the audio output of the receiver.

**RF GAIN:** Controls the sensitivity of the RF amplifier. In general this control should be ON (clockwise). However, by backing off the control, blocking of the receiver by extremely strong signals can be prevented.

**BAND SWITCH:** Changes bands as indicated on the front panel.

**ANT TUNING:** This control peaks the RF amplifier and should be readjusted for each band.

**ANL:** The ANL switch provides audio clipping of high noise pulses to provide reduced noise in the audio output.

**AVC:** The AVC switch serves a dual purpose of shutting off the S-meter and removing AVC from the RF amplifier and 1st IF stage. With AVC OFF, the RF gain control provides excellent control over receiver sensitivity.

**BFO:** The BFO control turns on and adjusts the frequency of an oscillator whose center frequency is 455 kc. This signal is injected into the emitter of the 2nd IF amplifier. This produces an audible beat note in the speaker, allowing reception of CW, SSB and teletype signals.

**PHONE JACK:** This jack provides a convenient method of connecting a set of earphones. The speaker is automatically cut out when an earphone jack is inserted in the receptacle. Although earphone output impedance is approximately 35  $\Omega$ , headsets of nearly any nominal impedance should prove satisfactory.

**MAIN TUNING:** The MAIN TUNING knob is used to tune the five bands on the top half of the dial. The main tuning is calibrated accurately only when the bandspread tuning knob is full clockwise.

**BANDSPREAD:** BANDSPREAD is used to tune the calibrated ham bands or to be used with the logging scale on the bottom half of the dial. With the bandspread tuning knob set full clockwise, set the main tuning pointer over the point indicated by the circle on the main dial containing the wavelength number (80M, 40M,

10 M, etc.), corresponding to the bandspread dial desired. Now, tuning the receiver with the bandspread tuning knob gives an expanded frequency scale for the amateur frequency band being used.

Using the logging scale, it is possible to return to any particular frequency within the tuning range of the receiver by noting the main tuning point and the logging scale reading.

**GROUND:** Whenever possible, it is recommended that a ground wire be connected to the ground screw of the rear antenna terminals. This will improve reception of signals regardless of the antenna utilized.

## BATTERY REPLACEMENT

If the receiver is operated with the battery power supply, the batteries will have to be replaced occasionally. A change in tuning or sensitivity when turning on the dial light is an indication of weak batteries. For battery replacement, use eight size "C", 1-1/2 volt flashlight cells.

# TUNING

## TUNING AM SIGNALS

The receiver controls should be set as follows:

VOLUME: ON one-half turn (clockwise).

BFO: OFF (pushed in).

BAND SWITCH: Desired band.

RF GAIN: Full ON (clockwise).

ANT. TUNING: Peaked after tuning in signal.

ANL: OFF (unless excess noise is present).

AVC: ON (unless copying a weak signal).

Tune signal to peak reading on S-meter, adjust VOLUME control for desired output level. Peak the antenna tuning. If signal is extremely strong, turn the RF GAIN control counterclockwise to reduce possible distortion.

## TUNING SSB OR CW SIGNALS

The receiver controls should be set as follows:

VOLUME: ON — nearly fully clockwise.  
BFO: ON. Set with the red pointer to the left index mark (pulled out) for lower sideband and to the right mark for upper sideband.

BAND SWITCH: Desired band.

RF GAIN: Reduce (counterclockwise) to eliminate RF amplifier gain after tuning in CW or SSB signal.

ANT. TUNING: Peaked after tuning in signal.

ANL: OFF (unless excessive noise is present).

AVC: OFF.

Tune in the signal, turn the VOLUME control full ON and control the audio output with the RF GAIN control. A slight amount of readjustment of the BFO will probably be required to accurately tune an SSB station to the desired pitch.

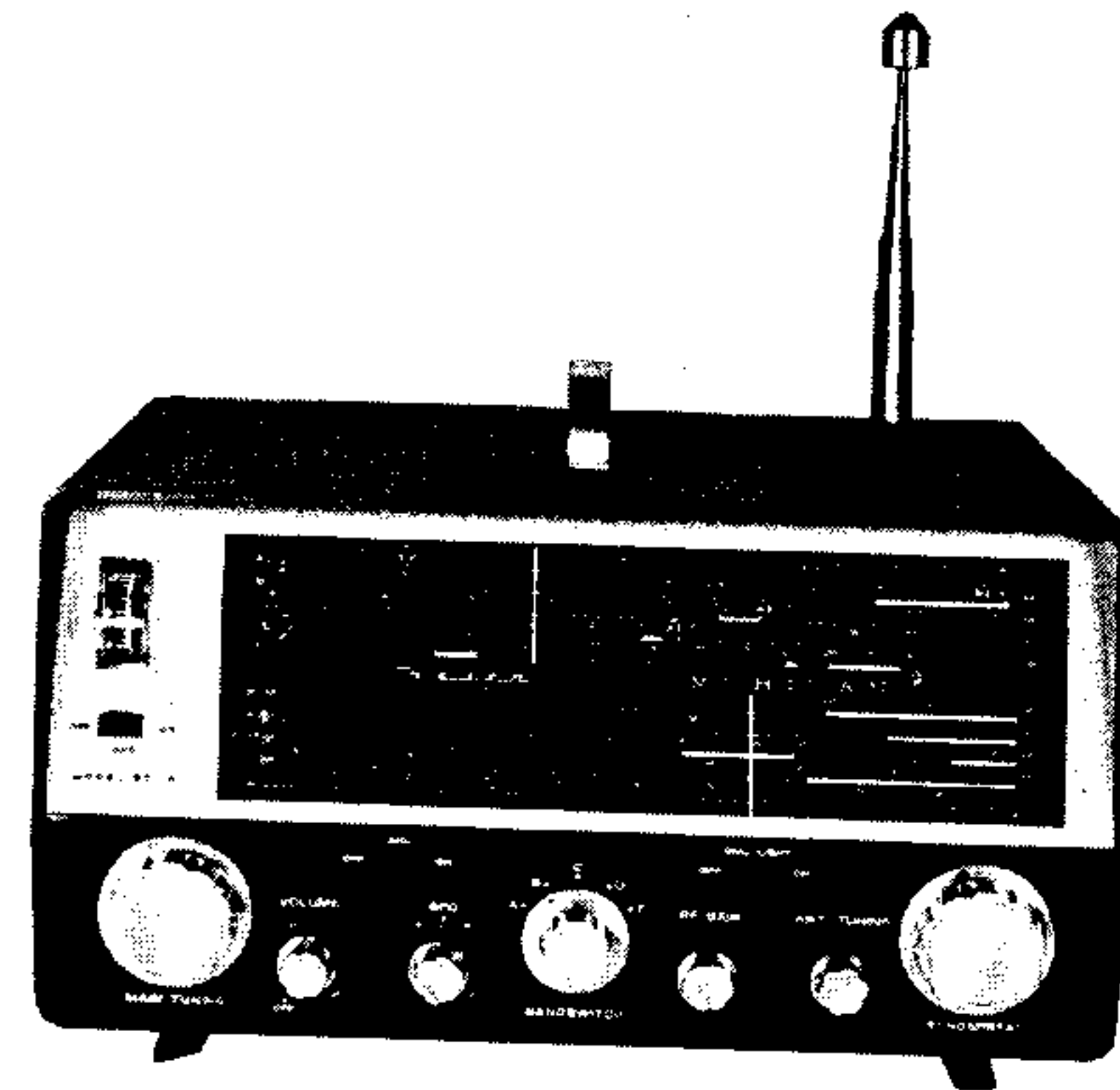

HEATH

## SPECIFICATIONS

### Receiver Type:

Ten transistor, general coverage, single conversion superheterodyne

### Intermediate Frequency:

455 kc.

### Frequency Coverage:

<u>Band</u>	<u>Frequency</u>
A . . . . .	550 kc - 1600 kc
B . . . . .	1.6 mc - 4.0 mc
C . . . . .	4.0 mc - 9.0 mc
D . . . . .	9.0 mc - 20.0 mc
E . . . . .	20.0 mc - 32.0 mc

### Selectivity:

3 kc wide at 6 db down.

### Sensitivity:

Band A - 10 microvolt = 10 db or better signal-to-noise ratio at 50 milliwatt audio output. Bands B, C, D and E - 2 microvolts = 10 db or better, signal-to-noise ratio at 50 milliwatt audio output.

### Rear Apron:

External antenna.  
Muting terminals.  
Phone jack.

### Semiconductor Complement:

2N1396 . . . RF Amplifier.  
2N1225 . . . Mixer.  
2N1225 . . . Oscillator.  
2N373 . . . 1st IF Amplifier.  
2N373 . . . 2nd IF Amplifier.  
2N373 . . . 3rd IF Amplifier.  
2N407 . . . Audio Driver.  
2N407 . . . Audio Output (2).  
2N409 . . . BFO.  
1N2326 . . . Compensating Diodes (2).  
1N754 . . . Zener Voltage Regulator.  
HD2257 . . . Germanium Diodes (3).

### Battery Life (8 "C" cells):

Up to 400 hours normal intermittent service.

### Output:

400 milliwatts at 10% distortion.

### Power Required:

12 volts at 35 ma - 50 milliwatt output.

### Size:

6-7/8" high x 12" wide x 10" deep.



# REPLACEMENT PARTS

PART No.	DESCRIPTION
<u>Resistors</u>	
1-2	68 $\Omega$ 1/2 watt
1-3	100 $\Omega$ 1/2 watt
1-4	330 $\Omega$ 1/2 watt
1-6	470 $\Omega$ 1/2 watt
1-9	1 K $\Omega$ 1/2 watt
1-11	1500 $\Omega$ 1/2 watt
1-14	3.3 K $\Omega$ 1/2 watt
1-16	4.7 K $\Omega$ 1/2 watt
1-20	10 K $\Omega$ 1/2 watt
1-22	22 K $\Omega$ 1/2 watt
1-24	33 K $\Omega$ 1/2 watt
1-25	47 K $\Omega$ 1/2 watt
1-27	150 K $\Omega$ 1/2 watt
1-42	270 $\Omega$ 1/2 watt
1-44	2.2 K $\Omega$ 1/2 watt
1-48	390 $\Omega$ 1/2 watt
1-67	39 K $\Omega$ 1/2 watt

PART No.	DESCRIPTION
1-95	560 $\Omega$ 1/2 watt
1-104	100 K $\Omega$ 1/2 watt
1-111	150 $\Omega$ 1/2 watt
1-113	5.6 K $\Omega$ 1/2 watt
1-128	62 K $\Omega$ 1/2 watt
1-129	4.7 $\Omega$ 1/2 watt
<u>Capacitors</u>	
20-40	470 $\mu\mu\text{f}$
20-98	12 $\mu\mu\text{f}$
20-99	22 $\mu\mu\text{f}$
20-100	30 $\mu\mu\text{f}$
20-101	47 $\mu\mu\text{f}$
20-103	150 $\mu\mu\text{f}$
20-104	130 $\mu\mu\text{f}$
20-105	180 $\mu\mu\text{f}$
20-106	390 $\mu\mu\text{f}$
20-107	680 $\mu\mu\text{f}$
20-109	62 $\mu\mu\text{f}$

PART No.	DESCRIPTION
20-111	230 $\mu\mu\text{f}$
20-112	310 $\mu\mu\text{f}$
21-14	.001 $\mu\text{fd}$
21-16	.01 $\mu\text{fd}$
21-26	.003 $\mu\text{fd}$
21-29	4.7 $\mu\mu\text{f}$
21-48	.05 $\mu\text{fd}$
21-53	.001 $\mu\text{fd}$ feedthrough
21-81	.1 $\mu\text{fd}$
21-82	.02 $\mu\text{fd}$
25-54	10 $\mu\text{fd}$ 10 V electrolytic
25-97	100-100-100 $\mu\text{fd}$ 15 V electrolytic
25-98	50 $\mu\text{fd}$ 15 V electrolytic
25-99	150 $\mu\text{fd}$ 15 V electrolytic
26-24	20 $\mu\mu\text{f}$ variable
26-62	Tuning capacitor
26-64	21 $\mu\mu\text{f}$ variable
31-23	Dual 8-60 $\mu\mu\text{f}$ trimmer
31-24	Triple 8-60 $\mu\mu\text{f}$ trimmer

HEATH

<u>PART No.</u>	<u>DESCRIPTION</u>	<u>PART No.</u>	<u>DESCRIPTION</u>	<u>PART No.</u>	<u>DESCRIPTION</u>
<u>Coils-Transformers</u>		<u>Knobs-Antenna-Speaker</u>		<u>Controls-Switches</u>	
40-274	Band A oscillator coil	462-59	1-3/4" knob	10-110	10 K $\Omega$ control
40-275	Band B oscillator coil	462-60	1-1/4" knob	19-50	2 K $\Omega$ control SPST switch
40-276	Band C oscillator coil	462-61	11/16" knob	19-51	5 K $\Omega$ control w/DPST switch
40-277	Band D oscillator coil	142-12	Antenna	60-1	SPST slide switch
40-278	Band E oscillator coil	401-33	Speaker, 35 $\Omega$	60-6	SPST slide switch (spring return)
40-279	Band A mixer coil	<u>Diodes-Meter-Lamps-Tran-</u>		60-13	DPDT slide switch
40-280	Band B mixer coil	<u>sistors</u>		63-238	Band switch
40-281	Band C mixer coil	56-4	Crystal diode		
40-282	Band D mixer coil	56-6	Zener diode 1N754 or equivalent		
40-283	Band E mixer coil	56-7	Compensating diodes 1N2326		
40-284	Band A antenna coil	407-68	Meter 0-1 ma edge reading		
40-285	Band B antenna coil	412-16	#49 pilot lamp		
40-286	Band C antenna coil	417-14	2N373 transistor		
40-287	Band D antenna coil	417-25	2N1396 transistor		
40-288	Band E antenna coil	417-26	2N1225 transistor		
40-289	BFO coil 455 kc	417-27	2N409 transistor		
51-54	Audio driver transformer	417-28	2N407 transistor		
52-35	IF input transformer				
52-36	IF output and detector transformer				



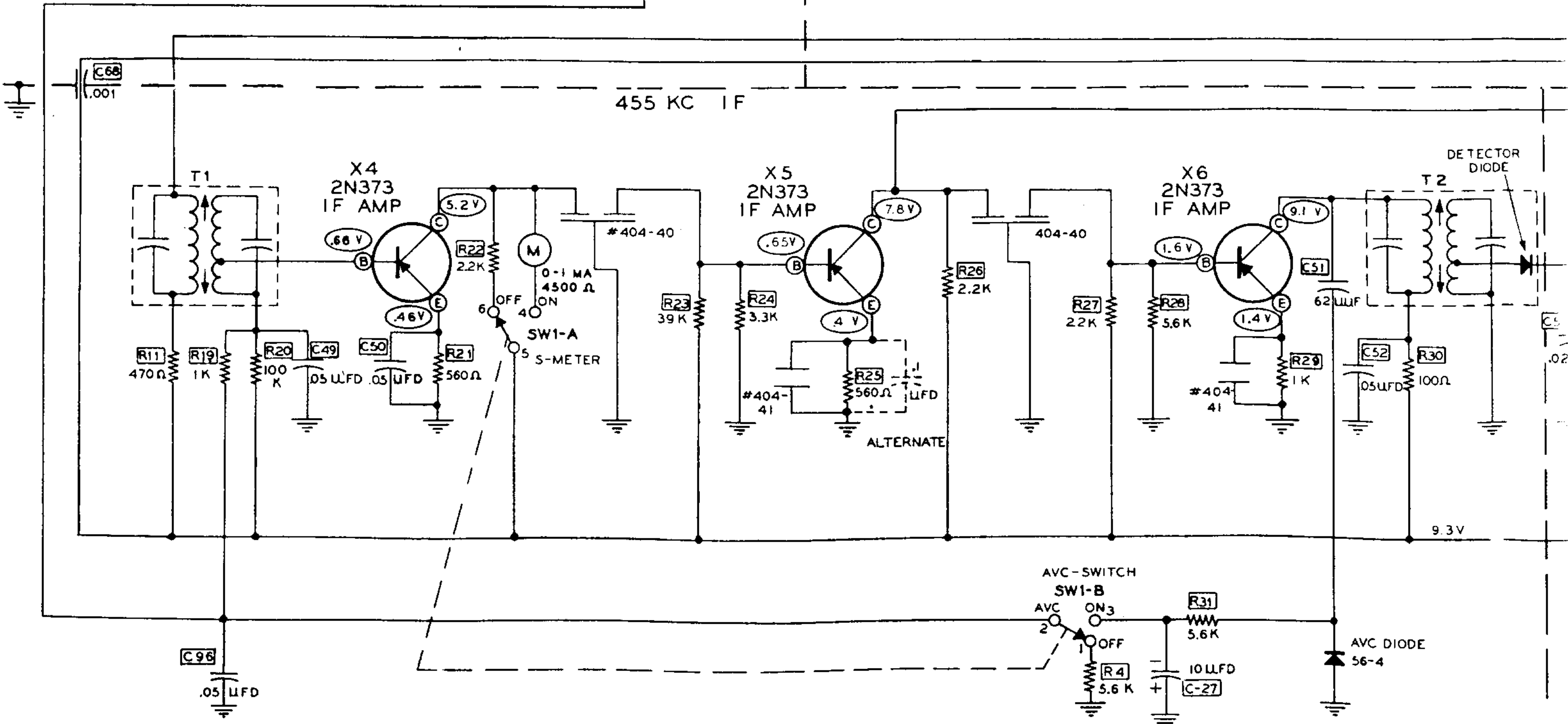
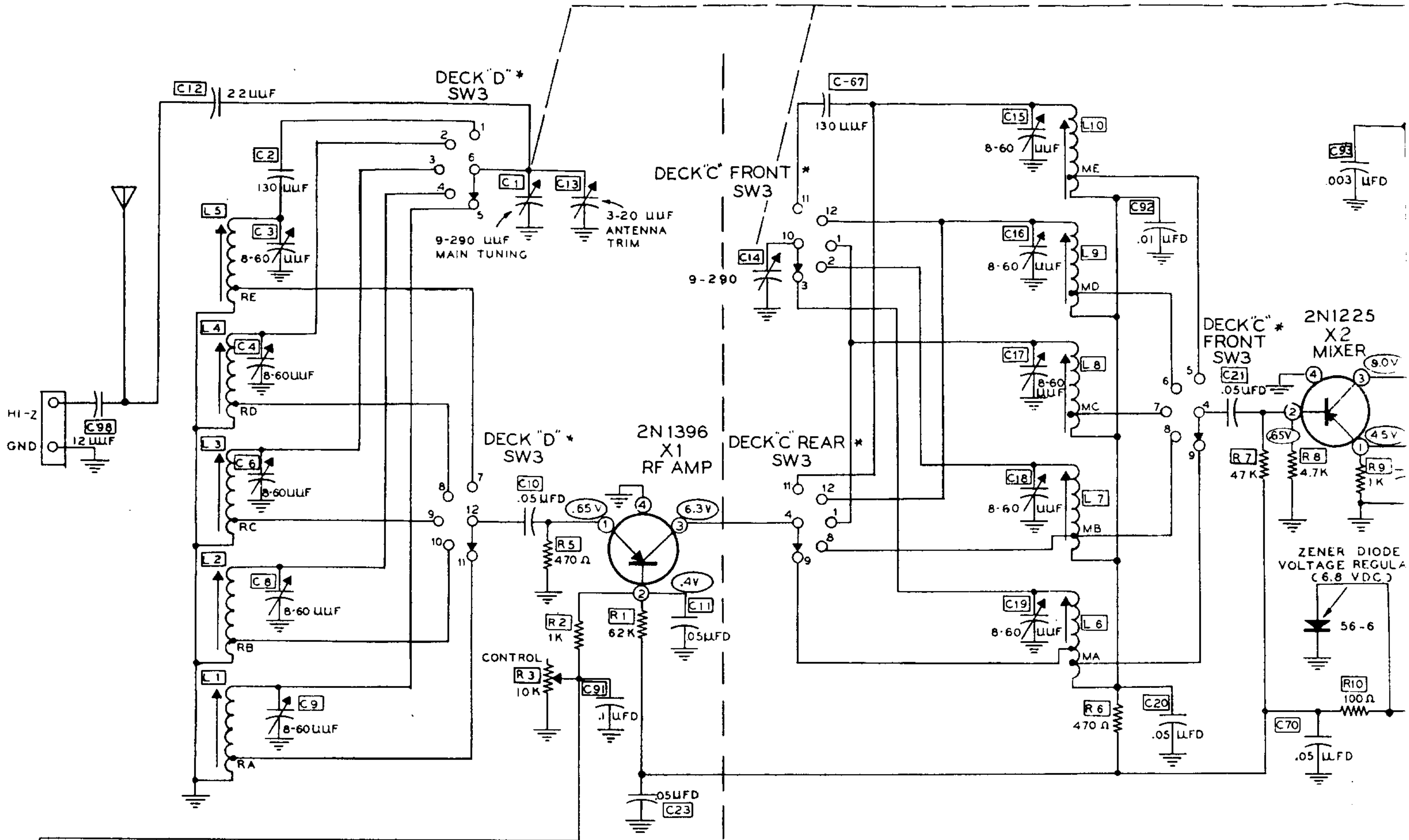

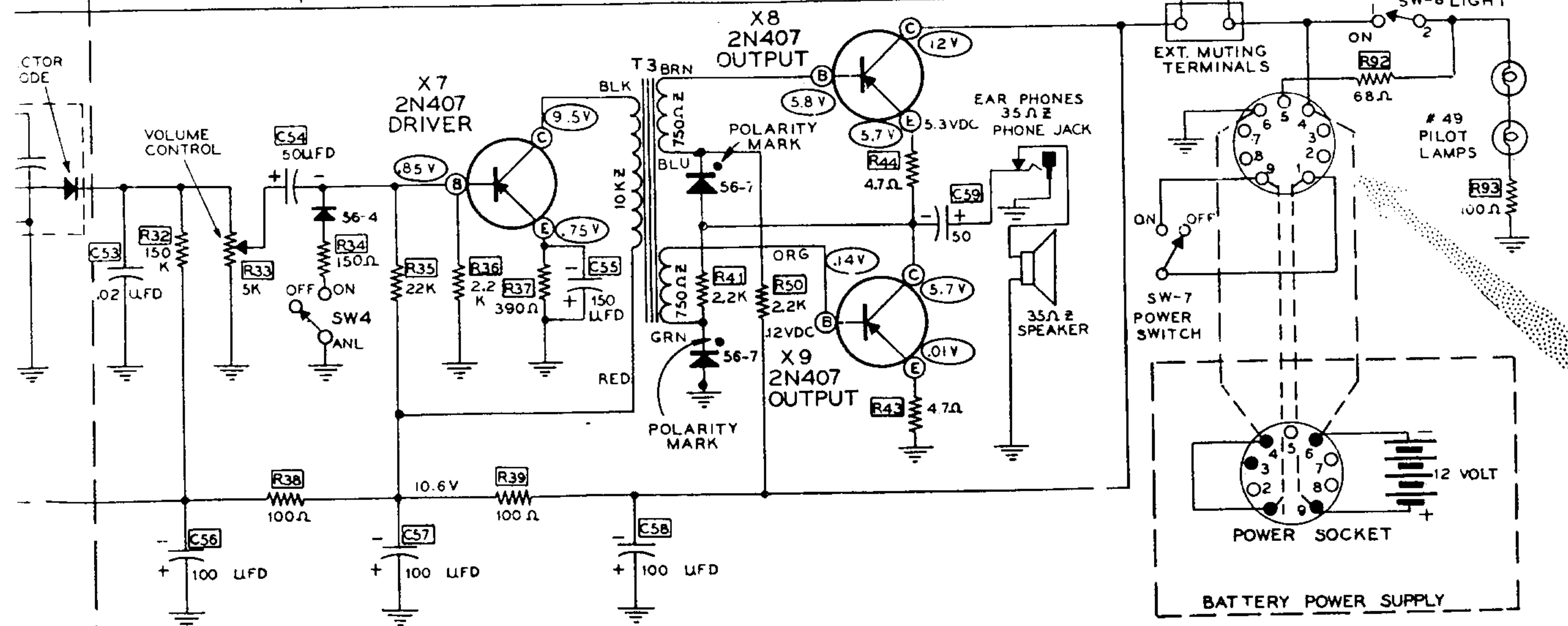
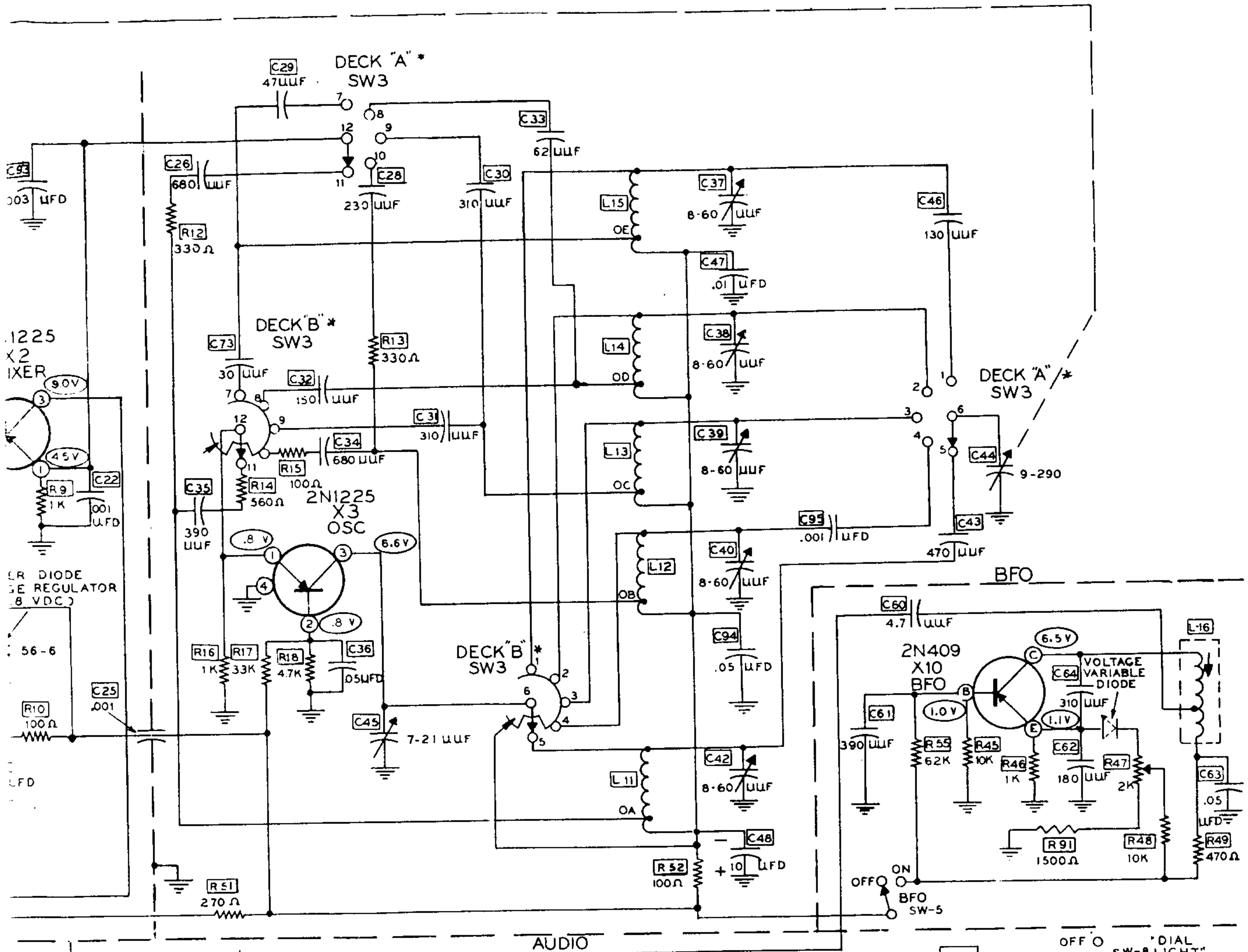

NOTE:  
 POWER PLUG NUMBERED IN REVERSE TO CONFORM TO MARKINGS ON PLUG. EXAMPLE: PIN #9 TO PIN #1, PIN #8 TO PIN #2, etc.  
 ALL VOLTAGES ARE NEGATIVE IN RESPECT TO CHASSIS GROUND.

MODEL W-GC-1A

