

**EVERYTHING 4 LESS**

**ENJOY YOUR BOOKS**

**PLEASE VISIT OUR STORE FOR EVEN MORE GREAT STUFF!**

**[WWW.EVERYTHING4LESSSTORE.COM](http://WWW.EVERYTHING4LESSSTORE.COM)**

**COPYRIGHT NOTICE**

**ALL MATERIALS INCLUDING CD/DVD AND PDF FILES ARE COPYRIGHTED**

**[WWW.EVERYTHING4LESSSTORE.COM](http://WWW.EVERYTHING4LESSSTORE.COM) VON WALTHOUR PRODUCTIONS AND MAY NOT BE REPRODUCED, COPIED OR RESOLD UNDER ANY CIRCUMSTANCES. YOU MAY HOWEVER MAKE A COPY FOR YOUR OWN PERSONAL BACKUP. MATERIALS ARE FOR PERSONAL USE ONLY.**

**IF YOU PURCHASED THIS FROM ANYWHERE BUT FROM US PLEASE NOTIFY US IMMEDIATELY SO THAT WE MAY CHECK IF YOU PURCHASED FROM AN AUTHORIZED RESELLER SO WE CAN LET YOU KNOW IF YOU NEED TO RETURN FOR FULL REFUND FROM AN UNAUTHORIZED SELLER.**

**THANKS AGAIN AND PLEASE TAKE THE TIME TO VISIT OUR STORE.**

**ATTENTION! EVERYTHING ON SALE NOW!!**



**HOT SALE!**

# Eddystone

## COMMUNICATIONS RECEIVER MODEL 840C

---

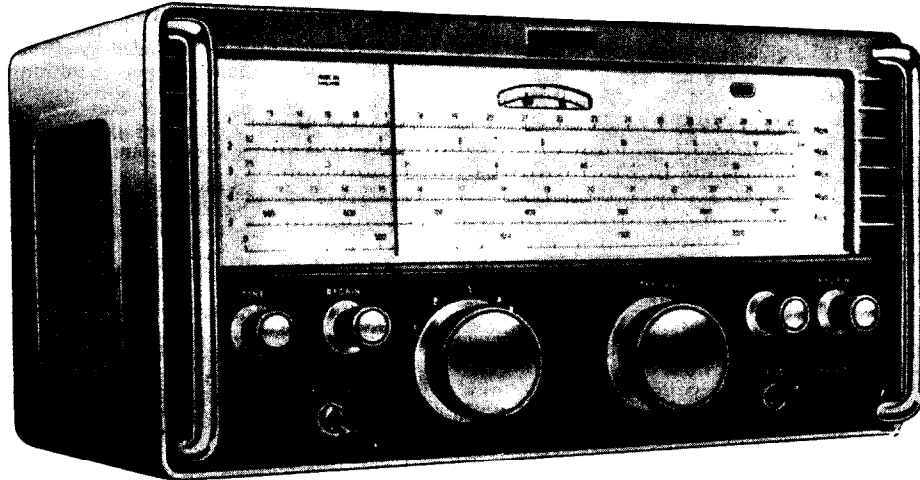

The EDDYSTONE Model 840C is a single conversion communications superhet receiver covering the band 480 kc/s to 30 Mc/s in five overlapping ranges. Provision is made for the reception of both AM and CW signals and although the receiver is not designed specifically for SSB reception, such signals can be received with careful tuning.

The receiver has a built-in power unit allowing operation from all standard AC and DC mains supplies. An internal loudspeaker is fitted and provision is made for connection of an external speaker unit. Telephones can be plugged into a socket on the front panel when a speaker output is not required.

Ease of operation is assured by the logical positioning and convenient dimensions of the major controls. The high grade gear driven slow motion tuning system allows extremely fine tuning, while the flywheel loading permits rapid movement from one end of a range to the other. Dial calibration

is directly in terms of frequency, the scales being linear and easy to read. A calibrated vernier is used in conjunction with a special logging scale so that dial settings can be recorded for future use. A visual tuning indicator is fitted as a further aid to accurate tuning. Independent manual gain controls together with an efficient automatic gain control circuit allow the receiver to be set for all levels of input signal and tone can be adjusted by means of a panel control.

Advanced design, rugged construction and high quality components are used throughout; the receiver is of a most convenient size, contemporary in appearance and suitable for continuous operation in all areas under extreme climatic conditions.

The five frequency ranges are as follows:—

- Range 1. 12.4 – 30 Mc/s.
- Range 2. 5.2 – 12.9 Mc/s.
- Range 3. 2.5 – 6.1 Mc/s.
- Range 4. 1.12 – 2.58 Mc/s.
- Range 5. 480 – 1150 kc/s.

## CIRCUIT DESCRIPTION

The 840C is an eight valve model and can be used on all AC/DC mains supplies in the ranges 100/125V and 200/250V. It has a single stage of RF amplification using a high gain pentode type UAF42 (V1) and a combined Mixer and Local Oscillator V2. This stage employs a UCH42 triode-hexode in which the triode portion functions as a tuned anode oscillator. Normal ganged tuning is employed in conjunction with a switched five range coil unit using precision wound inductors.

The IF output from the Mixer Stage is at 450 kc/s and a single stage of amplification is provided at this frequency. Two permeability tuned transformers provide excellent selectivity and the IF valve (V3) is a UAF42.

The diode in the IF valve envelope is used as AGC Rectifier and controls the RF, IF and Mixer Stages on Ranges 3, 4 and 5 while on Ranges 1 and 2 the RF and IF Stages only are controlled to prevent oscillator pulling. AGC is removed from all stages when the BFO is switched in and it should be noted that the AGC delay is affected by the RF Gain control which should always be set to maximum when AGC is in use. The visual tuning indicator V4 which is a miniature DM70 is controlled by the Detector Stage and is therefore operative with or without AGC.

V5 is another UAF42 serving as Signal Detector and 1st Audio Amplifier. The detector is a series diode type and the pentode portion of the valve is fed from the AF Gain control which forms part of the detector load. Output from the pentode is resistance-capacity coupled to the following valve V7 (UL41). Negative feed-back is applied to this stage and the high quality output transformer feeds either a loudspeaker or low impedance telephones. Tone control is by means of a variable resistor (RV3) in series with a capacitor across the primary of the output transformer.

The Beat Frequency Oscillator (V6) is also a UAF42 and employs a conventional electron coupled circuit. The frequency of oscillation is variable by means of a panel control to permit adjustment of the pitch of the note when receiving CW signals.

Two gain controls are provided, the RF Gain which takes the form of a variable resistor in series with the common cathode return of V1 and V3 and the AF Gain which is a potentiometer control in the output of the signal detector.

Provision is made for desensitising the receiver when it is not required but must be available for immediate use. This is achieved by means of the Standby switch which applies a large bias to the RF and IF stages when switched to 'standby.' HT supplies remain on all stages during standby periods so that frequency stability is maintained when the receiver is not in use.

The power supply circuitry is quite conventional and includes the normal half wave rectifier V8 (UY41), the smoothing circuit and the ballast resistor which feeds the series/parallel connected heater chain. A thermistor is incorporated in this circuit to reduce the current surge at 'switch-on' and this prolongs the life of the valves used in the receiver. No indicator lamp is fitted since this function is effectively performed by the visual tuning indicator which exhibits a blue glow when the receiver is operative.

## CONSTRUCTION

The chassis assembly in the 840C is totally isolated from the panel and cabinet and complies with the relevant standards with regard to safety from shock applicable to AC/DC equipment.

Specially fabricated insulating pieces are employed at all fixing points between the chassis and the remainder of the unit and when correctly installed the cabinet and panel are directly earthed and the internal chassis is totally inaccessible. All the fixing arrangements for control knobs, switches, etc. are either fully insulated by virtue of their inaccessibility or are directly earthed to the panel. Aerial connections, etc. are also completely safe.

The chassis assembly is made up in three parts. These are the central coil unit which is an aluminium diecasting, the IF/AF chassis and the Power Unit chassis. The IF/AF chassis is made from brass and is mounted on the right of the coil unit. The Power Unit is built on a rustproofed steel chassis and occupies the same relative position as the IF/AF chassis but to the left of the coil unit.

The panel is an aluminium diecasting having four fixing holes for attachment of the coil unit. At the extreme ends of the panel are the two steel chassis support plates which make direct contact with the panel but are insulated from the chassis which they support. Fixing to the panel is by means of the four screws which secure the chromium plated panel handles. These handles make for ease in lifting the receiver and also allow it to be placed 'face down' when removing the cabinet. Ample clearance is provided to avoid damage to the panel controls when the receiver is placed in this position.

The high flux 6½" speaker unit is mounted on the left-hand chassis support plate and precautions have been taken to avoid undesirable cabinet resonance.

The cabinet is stoutly made from rustproofed steel, is provided with adequate ventilation areas and a loudspeaker grille: apertures at the rear allow connection to the aerial, external speaker, etc. The cabinet is easily removed after taking out the four large screws at the back.

All external connections with the exception of the telephone socket are located on an insulated panel positioned at the rear of and extending the full width of the chassis assembly. It is attached to the chassis support plates and serves to support the rear of the coil unit and the sub-chassis which make up the complete chassis assembly.

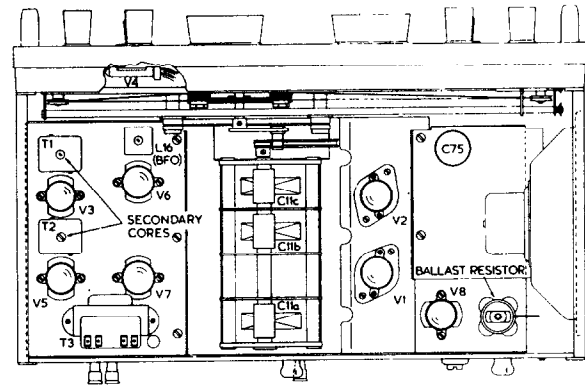

Plan view of receiver

## INSTALLATION

### Mains Voltage Adjustment

The Model 840C can be operated equally well from either AC or DC mains supplies. No adjustment is necessary when changing from AC to DC but it is important to check that the voltage selector at the rear of the receiver is set to suit the local mains voltage before making connection to the supply.

When despatched from the factory, the selector is placed in the 230V position which is correct for operation from mains voltages in the range 225-250V. If the local mains supply is between 200-225V the selector plug should be withdrawn from the 230V socket and plugged into the 200V position. The 110V socket is suitable for mains supplies in the range 100-125V.

### Mains Connections and Earthing

The mains input is taken via a small plug and socket at the rear of the cabinet, the plug being ready wired with six feet of three-core mains cable. One end of the cable is left free so that the user can fit a plug of a type suitable for connection

to the local mains supply. If the existing cable proves too short, it can easily be disconnected from the plug and replaced by a longer length. In most cases the existing length will be adequate and this is coded as follows:—  
 Red: Live (Positive DC), Black: Neutral (Negative DC), Green: Earth.

When it is necessary to fit a two-pin mains plug in lieu of the more usual three-pin type, the green lead should be cut off short and pressed back into the cable covering so that there is no chance of it shorting to the other leads. With three-pin plugs the green lead should be connected to the thicker of the three pins.

Inside the set the green lead is connected directly to the cabinet and panel and if the mains earth is reasonably short there will be no need to connect an earth at socket 'E.' However, if the mains earth is rather long, improved reception may be obtained if socket 'E' is connected to a more direct earth. It is important to note that in cases where there is no connection to socket 'E,' the plug supplied must still be in position to complete the earth to the internal chassis. Leaving the plug out will reduce the sensitivity of the receiver especially when using single wire aerials. When there is no connection to the green earth lead an earth must be connected to socket 'E.'

On AC supplies when a three-pin plug is in use, the red lead should be connected to the pin that engages with the right-hand socket of the wall fitting. This is true on the assumption that the wall fitting is wired correctly but if as is sometimes the case the wall fitting is wired incorrectly, it may be found that an objectionable hum appears in the output from the receiver. Reversing the connections to the plug will remove the hum.

Two-pin AC plugs should be reversed if a hum is present and can then be marked to indicate the correct orientation.

On DC, the receiver will function only if the polarity of the supply is correct. Thus, if the set fails to operate after the normal warming up period, reversal of the plug will clear the trouble.

#### The Aerial

The Model 840C is an extremely sensitive receiver and will give a good account of itself even on poor indoor aerials. For best possible reception an outside antenna is a worthwhile investment. This can be any length up to some 100 feet or so, well insulated and situated clear of all local obstructions especially those of a metallic nature. Single wire aerials of this type are connected at the right-hand socket labelled 'A'. The shorting plug must be in position between the other 'A' socket and earth.

For improved reception over restricted frequency bands (or when local noise is a problem) a dipole cut to the correct length is probably the most suitable arrangement. Aerials of this type have a 'T' formation with a twin balanced feeder which helps to reduce noise pick-up on the lead-in. When using a dipole aerial, the shorting plug is removed and the two feeder wires are connected to the two 'A' sockets. Other advantages of the dipole are that the feeder can be of any length so allowing the aerial proper (the top portion of the 'T') to be placed in the most suitable position, while the feeder can be run close to obstructions without adverse effect on the performance. A disadvantage of the dipole is that performance is only optimum over the band for which it is designed. Improved performance can sometimes be obtained on frequencies for which the dipole is not resonant if the twin feeders are strapped together and connected to the right-hand 'A' socket. In this case, the shorting plug should be in position since the aerial is effectively a single wire arrangement.

The overall length of a dipole is calculated by dividing the frequency in Mc/s into 468. The result will be in feet and some idea of actual lengths can be obtained from the figures for the amateur communication bands which are listed below.

Band (Metres)	160	80	40	20	15	10
Freq. (Mc/s.)	1.8	3.5	7	14	21	28
Length (ft.)	264	132	66	33	22	16.5

#### Connecting an External Loudspeaker

An external loudspeaker can be connected after taking out the internal speaker plugs at the rear of the set (labelled L.S.—2.5 ohms). The external speaker should be fed with standard twisted flex terminated with suitable plugs. No transformer is required and the speaker should be a standard 2.5/3 ohm type. Both speakers can be operated simultaneously if their leads are connected in parallel but there will be some drop in the volume level of each speaker.

#### OPERATION

Once the receiver has been correctly installed it can be switched on by rotating the tone control in a clockwise direction to operate the mains switch which is ganged to it. A short period will elapse during which the valve heaters will reach operating temperature prior to the receiver becoming fully operative. A check should be made that the standby switch is in the down position.

The AGC/BFO switch should be set to 'AGC' for telephony reception or 'BFO' if CW reception is required. In the case of telephony, best AGC action will be obtained if the RF Gain is fully advanced. Under these conditions the volume level is controlled by means of the AF Gain at the extreme right-hand side of the panel. For CW reception the AF Gain should be advanced and the RF Gain turned down to prevent overloading of the receiver on strong signals. A little practice will result in a natural balance being found in the settings of the two controls.

The BFO Pitch control permits adjustment of the audible beat obtained when receiving CW signals. The control will normally be offset slightly to provide a note of about 1000 cycles for maximum readability. The same beat can be obtained at two settings of the control and it may be found that one setting gives less interference than the other.

If the receiver is not required but must be ready for instant use, the standby switch should be placed at standby (up position). Frequency stability is held within close limits during standby periods since the local oscillator remains in operation at all times.

The setting of the tone control may be decided by the quality required or alternatively by the type of interference and type of signal being received. Some experimentation with the adjustment of this control will be found invaluable.

In cases where loudspeaker reception is not convenient, telephones can be connected at the socket on the panel. The speaker is automatically cut when the phone plug is inserted.

All standard Broadcast bands are marked in red, Amateur allocations in black. Dial settings can be recorded for future reference by combining the vernier scale reading with the setting on the bottom logging scale.

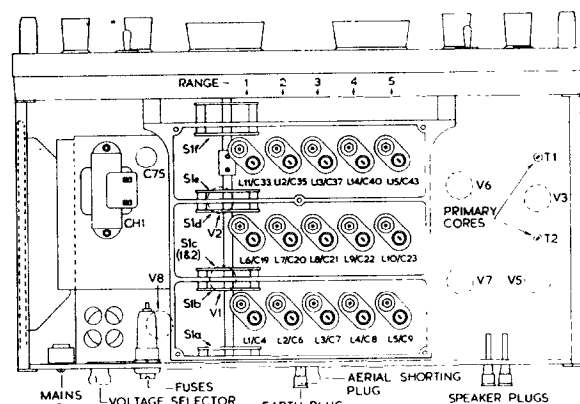

Underside view of receiver

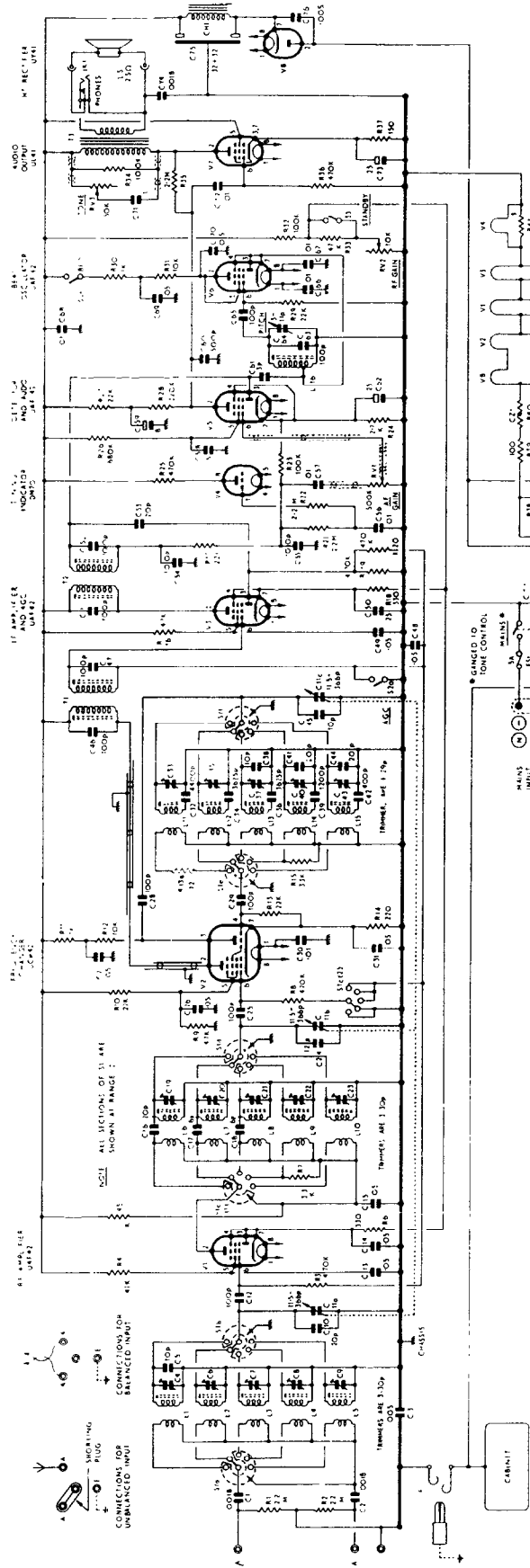

### COMPONENT VALUES

#### CAPACITORS.

C1	1800 pf.	C35	100 pf.	C65	100 pf.	C95	100 pf.
C2	1800 pf.	C36	100 pf.	C66	100 pf.	C96	100 pf.
C3	0.005 mfd.	C37	100 pf.	C67	100 pf.	C97	100 pf.
C4	3-30 pf.	C38	100 pf.	C68	100 pf.	C98	100 pf.
C5	10 pf.	C39	100 pf.	C69	100 pf.	C99	100 pf.
C6	3-30 pf.	C40	100 pf.	C70	100 pf.	C100	100 pf.
C7	3-30 pf.			C71	100 pf.		
C8	3-30 pf.			C72	100 pf.		
C9	3-30 pf.			C73	100 pf.		
C10	11.5-366 pf.			C74	100 pf.		
C11	100 pf.			C75	100 pf.		
C12	0.05 mfd.			C76	100 pf.		
C13	0.05 mfd.			C77	100 pf.		
C14	0.05 mfd.						
C15	0.05 mfd.						
C16	20 pf.						
C17	6 pf.						
C18	3-30 pf.						
C19	3-30 pf.						
C20	3-30 pf.						
C21	3-30 pf.						
C22	3-30 pf.						
C23	12 pf.						
C24	100 pf.						
C25	0.05 mfd.						
C26	0.05 mfd.						
C27	100 pf.						
C28	100 pf.						
C29	100 pf.						
C30	0.01 mfd.						
C31	4400 pf.						
C32	4-29 pf.						
C33	3625 pf.						
C34	4-29 pf.						
C35	1625 pf.						
C36	4-29 pf.						
C37	10 pf.						
C38	1200 pf.						
C39	4-29 pf.						
C40	20 pf.						
C41	400 pf.						
C42							

#### POTENTIOMETERS.

PV1	0.5 Megohm carbon.
PV2	10,000 ohms wirewound.
PV3	50,000 ohms carbon with double pole switch.

#### RESISTORS.

R1	2.2 Megohms.
R2	2.2 Megohms.
R3	0.47 Megohm.
R4	47,000 ohms.
R5	1,000 ohms.
R6	330 ohms. ±5%.
R7	3,300 ohms.
R8	27,000 ohms.
R9	17,000 ohms.
R10	10,000 ohms.
R11	10,000 ohms.
R12	22,000 ohms.
R13	22,000 ohms.
R14	170 ohms.
R15	3,300 ohms.
R16	47,000 ohms.
R17	22,000 ohms.
R18	330 ohms. ±5%.
R19	0.47 Megohm.
R20	0.47 Megohm.
R21	2.2 Megohms.
R22	2.2 Megohms.
R23	0.1 Megohm.
R24	2,700 ohms.
R25	0.47 Megohm.
R26	0.68 Megohm.
R27	22,000 ohms.
R28	0.22 Megohm.
R29	22,000 ohms.
R30	1,000 ohms.
R31	10,000 ohms.
R32	0.1 Megohm.
R33	47,000 ohms.
R34	0.1 Megohm 1 watt.
R35	2.2 Megohms.
R36	0.47 Megohm.
R37	150 ohms.
R38	550 ohms. tapped at 100 ohms.
R39	and 350 ohms 0.2 amps.
R40	100 ohms ±5% 4 watts.
R41	8 ohms. 3 watts.
R42	C71 Thermistor.

NOTE: All resistors are 10% ± watt unless stated otherwise.

## SERVICING INSTRUCTIONS

**CAUTION.** The Model 840C is a universal type and great care should be taken when carrying out tests with the cabinet removed. When running from AC supplies it is advisable to ensure that the chassis is connected to the neutral pole of the supply. If an isolation transformer is available this will be found more convenient and can be operated at an output voltage of 110V as a further safety precaution.

Should the receiver fail in operation, first check that all external connections are correctly made and also that mains voltage is available at the supply point. Next check the fuses. These are located in insulated holders at the rear of the receiver and are easily removed without risk of electric shock. Visual inspection will reveal whether or not a fuse has blown. Replacements should be standard  $1\frac{1}{4}$ " cartridge types rated at 500 mA ( $\frac{1}{2}$  Amp). If a blown fuse is changed and the replacement burns out immediately or after a very short period of operation, it is an indication that some internal component is faulty. In this case the receiver should be taken to the nearest EDDYSTONE Agent who will rectify the trouble at a reasonable charge.

If it is necessary to take the receiver to an engineer who is not familiar with Eddystone equipment, take this instruction sheet with the set. It contains information which may enable him to clear the fault more rapidly than would otherwise be the case.

### Valve Replacement

All the valves used in the Model 840C are easily accessible when the cabinet is removed. All except the tuning indicator have B8A bases. The pins on these bases are equally spaced and correct location of the valve in relation to the holder is achieved by means of a small glass pip on the side of the envelope base. This locates with a retaining slot in the base fitting. Care should be exercised in removing and replacing valves not to exert any sideways strain since this could result in fracture of the glass envelope.

The visual tuning indicator has a miniature B8D base and is retained in a small metal clip. The indicator can be removed by sliding it out of the clip after freeing it from the base.

When fitting a replacement indicator it will be necessary to trim the four long lead-out wires to the same length as the four shorter ones. The leads should be carefully straightened to line up with the sockets so that the indicator can be plugged into its base. When sliding back into the clip, make sure that the 'keyhole' in the indicator lines up with the aperture in the scale plate.

### Pointer Drive Cord Replacement

In the unlikely event of the drive cord either breaking or slipping out of the pulley grooves, replacement will be much simplified (even when the original cord is undamaged) if a new length is obtained. This can be made longer than the length actually required ( $3' 8\frac{1}{2}"$ ) and will therefore be easier to handle. Replacement will present no problems if the following instructions are followed carefully.

**NOTE:** In these instructions, left and right are as viewed from the rear of the receiver.

1. Remove the cabinet after taking out the four retaining screws at the rear.
2. Take off the old drive cord by slackening the 8BA screws let into the drive pulleys.
3. Set the tuning control so that the tuning gang is fully meshed.
4. Secure one free end of the replacement cord to the 8BA screw in the left-hand drive pulley.
5. Feed the cord through the pulley slot and into the groove nearest the panel (cord leaving pulley from right to left.)
6. Pass the cord below the tuning indicator, clockwise round the jockey pulley and across the dial between the

pointer guide rods. Sufficient tension should be applied to cause the jockey pulley to take up a position one quarter of an inch from the guide rod support bracket.

7. Move the pointer to the right-hand end of the guide rods (nearest to speaker) and slide the cord up and over the retaining spring. The spring may be depressed slightly to simplify this operation.
8. Take the cord round the right-hand guide pulley and across towards the right-hand drive pulley.
9. Lay the cord in the groove nearest to the panel and wind three complete turns in an anti-clockwise direction. Ensure that the cord lies snugly in the pulley grooves and that the tension is maintained at the jockey pulley.
10. Holding the free end of the cord reasonably tight, rotate the tuning control to unmesh gang. Approximately three turns of the control will be required and this operation will place the tie-off screw in the drive pulley in an accessible position.
11. Press the cord into the pulley slot, round 8BA screw and secure.
12. Check that the jockey pulley is correctly tensioned and then cut off the surplus cord at the right-hand drive pulley.
13. Move gang to fully meshed position and set pointer to 'O' on logging scale. Check drive for free and normal operation and correct vernier tracking.
14. Check the dial calibration against a suitable frequency standard.
15. Replace cabinet and fit retaining screws.

### Cleaning the Scale and Scale Window

1. Locate the three screws disposed vertically at each end of the rear of the scale plate. Take out the centre screw at each end and remove the small side castings at the extremities of the glass window.
2. Slacken the four countersunk screws along the top edge of the panel and slide back the white scale support.
3. The glass is now free and can be removed by lifting up and tilting back slightly.

### Re-alignment — General

In the unlikely event of a complete re-alignment being necessary the following instructions should be followed in full. In the more usual case of partial alignment required to compensate for ageing components, etc. the relevant instructions can be extracted as required.

It should be stressed that alignment adjustments should not be tampered with unless there is a clear indication that re-alignment is in fact required. Adjustment should only be carried out by fully skilled technicians equipped with adequate test equipment.

### Re-alignment of the IF Transformers and BFO

First disable the local oscillator by shorting out the forward section of the tuning gang (C11c). Set the Range switch to 5, tuning to 500 kc/s and the RF and AF Gain controls to maximum. The Tone control should be rotated fully clockwise and the AGC/BFO switch set to AGC to disable the BFO. The AGC line should be connected to chassis either at S2a or at T1. Connect the signal generator output leads via 0.01 mfd isolating capacitors to the Mixer section of the tuning gang (C11b). Unplug the internal speaker connections at the rear and connect an output meter matched to 2.5/3 ohms in their place.

Allow some 10 minutes for warming up and then tune the signal generator to 450 kc/s with modulation at a depth of 30% (400 c/s). Adjust the attenuator for a convenient output

and then peak the cores in T1 and T2 for maximum reading on the meter. It should be noted that the cores in T1 are set to the outer peak and those in T2 to the inner peak.

Increase the attenuation as alignment proceeds and ensure that on completion a sensitivity of at least 35uV is obtained for an output of 50mW. If this figure cannot be achieved some improvement may be forthcoming if V3 is changed. If a spare UAF42 is not available try changing with V6.

Once the IF transformers are peaked to the generator frequency, cut the modulation, reconnect the loudspeaker and place the AGC/BFO switch at BFO. Set the BFO Pitch control so that the white index line is at "12 o'clock" and then adjust the core setting of L16 for zero beat.

The link connecting the AGC line to chassis can be left in place so that the receiver can be operated with both BFO and AGC 'off' (switch at AGC) while carrying out RF alignment. The signal generator leads should be removed from the Mixer section of the tuning gang as should the temporary short on the oscillator section.

#### RF Alignment

The first step in re-alignment of the RF Section of the receiver is a check on the accuracy of the dial calibration to ascertain whether adjustment is required in the oscillator stage. This check is best carried out using a crystal controlled harmonic generator or frequency meter since the accuracy of the average signal generator is less than the scale accuracy of the receiver (0.5%). The marker signal should be introduced at the aerial input and checks made at 100 kc/s intervals throughout each of the five ranges. If the indications are that calibration accuracy is outside the limit quoted, re-alignment of the oscillator tuned circuits will be required. Standard tracking procedure should be adopted using the alignment points and adjustments listed in the table below.

Range	Trimming Frequency	Trimmer	Padding Frequency	Core
1	28 Mc/s	C33	14 Mc/s	L11
2	12 Mc/s	C35	5.8 Mc/s	L12
3	5.6 Mc/s	C37	2.7 Mc/s	L13
4	2.4 Mc/s	C40	1.25 Mc/s	L14
5	1060 kc/s	C43	520 kc/s	L15

The oscillator tracks "high" on all ranges. On Ranges 1 and 2 it may be possible to set the oscillator on the low side of the signal and a check should be made to ensure that the response with minimum capacity or minimum inductance is selected. Care should be taken to balance any interaction between the trimming and padding adjustments which should be repeated at least twice to achieve the desired accuracy.

Once the scale calibration has been checked and corrected if necessary, alignment of the RF and Mixer circuits can be

commenced. The output meter should be connected to provide a clearer indication of maximum output than is possible with the speaker alone. The receiver input impedance is 75 ohms and the signal generator (modulated 30% at 400 c/s) should be arranged to match this impedance when connected to the aerial input socket at the rear. Alignment adjustments are made at the following frequencies tuning for maximum output with the appropriate trimmer or core. As with oscillator alignment, each adjustment should be repeated at least twice to reduce errors due to interaction.

Range	Trimming			Padding		
	Freq.	RF	Mixer	Freq.	RF	Mixer
1	28 Mc/s	C4	C19	14 Mc/s	L1	L6
2	12 Mc/s	C6	C20	5.8 Mc/s	L2	L7
3	5.6 Mc/s	C7	C21	2.7 Mc/s	L3	L8
4	2.4 Mc/s	C8	C22	1.25 Mc/s	L4	L9
5	1060 kc/s	C9	C23	520 kc/s	L5	L10

#### TABLE OF VOLTAGE VALUES

The following voltage readings will be of use during servicing operations. In each case, the first reading is that obtained using a meter of 20,000 ohms/volt; the second 600 ohms/volt. A variation of  $\pm 5\%$  should be allowed.

Stage	Anode	Screen	Cathode
V1	112V/110V	67V/45V	1.4V/1.3V
V2	Triode	90V/80V	—
	Hexode	115V/110V	62V/40V
V3	115V/114V	62V/45V	1.5V/1.3V
V4	50V/15V	—	—
V5	25V/10V	22V/10V	1.3V/0.7V
V6	62V/57V	62V/57V	—
V7	105V/105V	115V/115V	6.5V/6.0V
V8	135V/135V*	—	—

\* AC. All other readings are DC taken between the point indicated and chassis. Readings taken on Range 5, gains at maximum, BFO and Standby to 'ON.' Mains 240V.

HT Voltage .. 115V                      HT Current .. 65mA  
Total Current .. 280mA.

Manufacturers :

**EDDYSTONE RADIO LIMITED**  
**ALVECHURCH ROAD, BIRMINGHAM 31**



Telephone : PRIORY 2231

Cables : EDDYSTONE, BIRMINGHAM

Telex : 33708



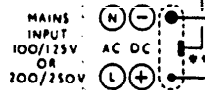
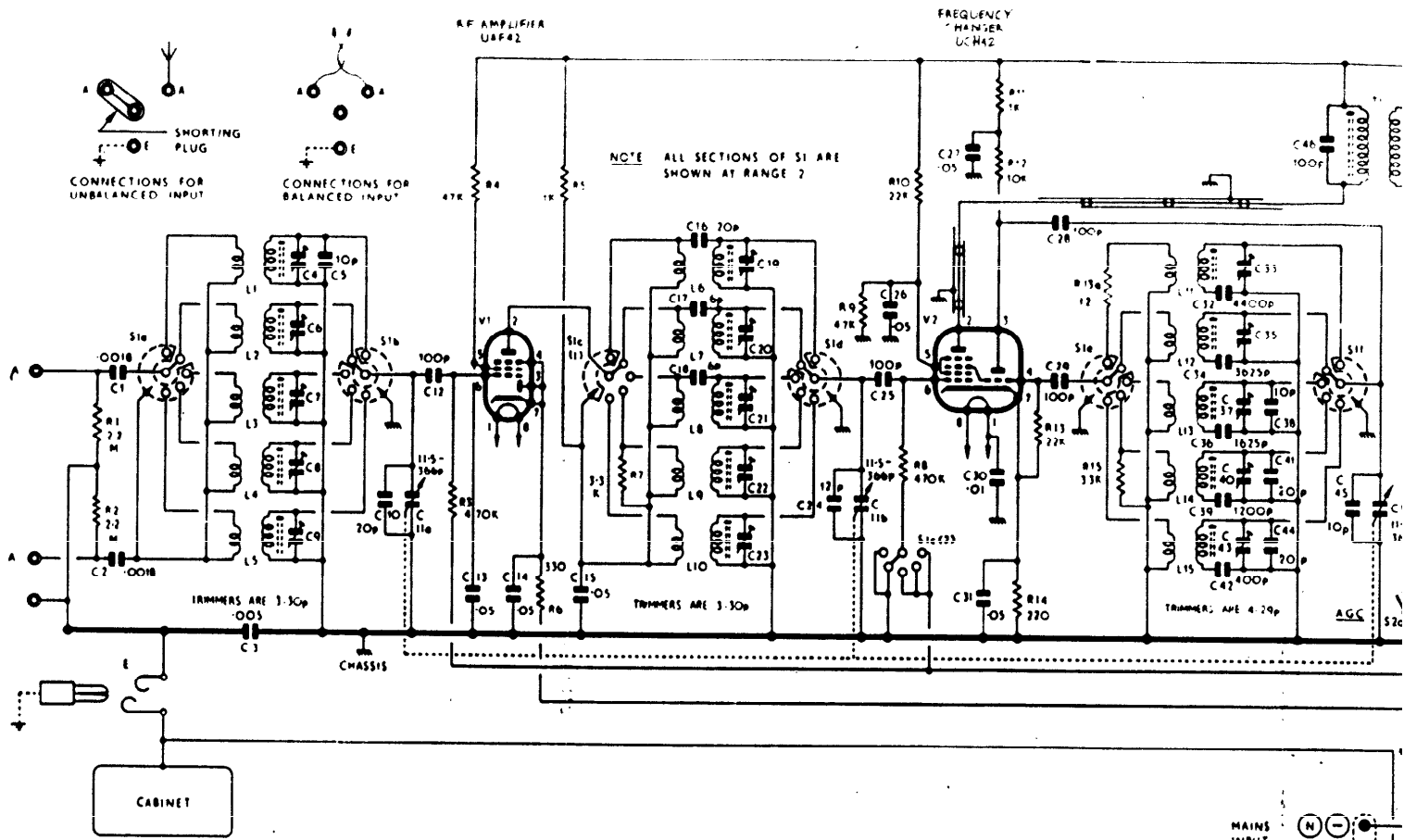



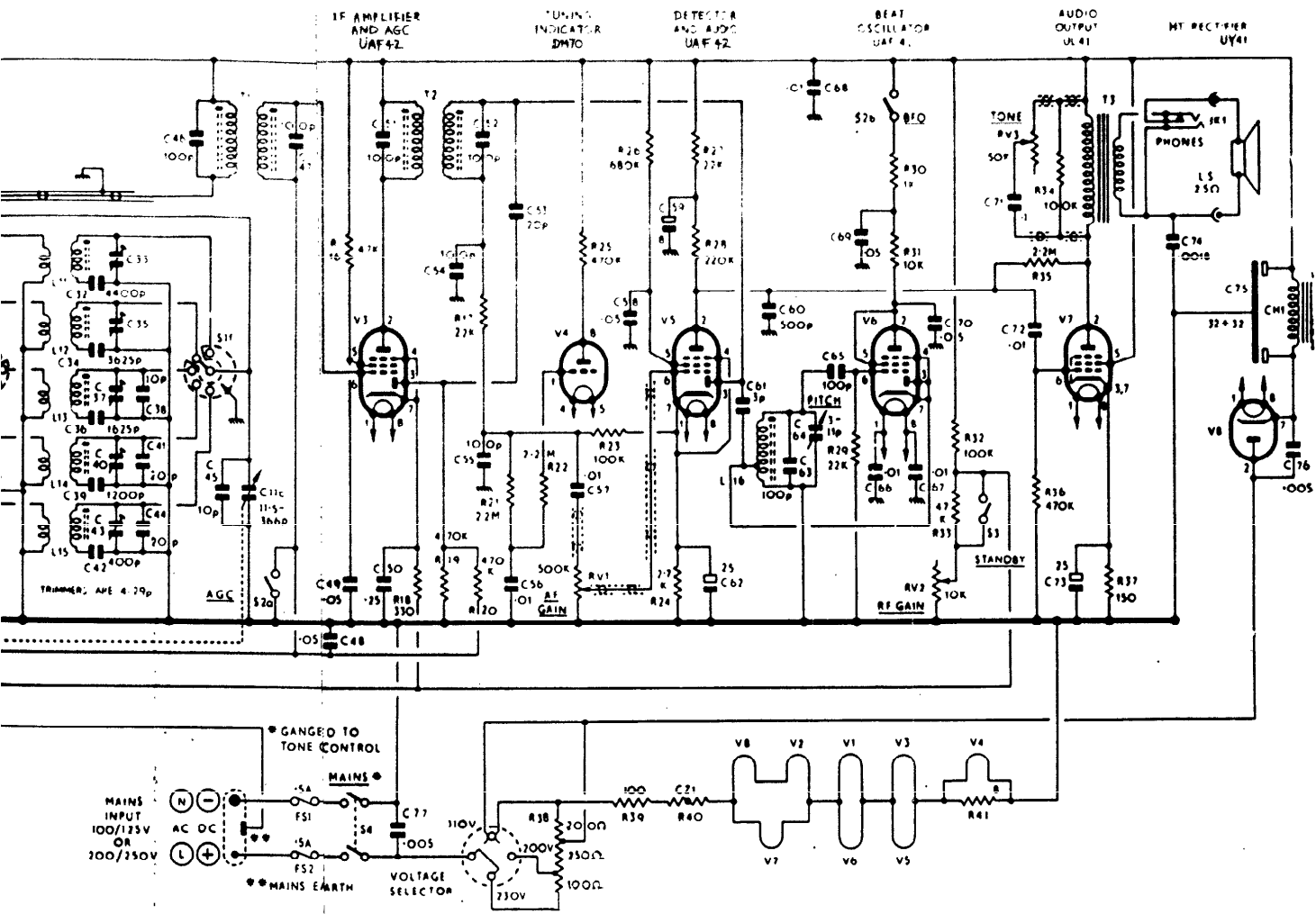

**EVERYTHING 4 LESS**



**ENJOY YOUR BOOKS**



**PLEASE VISIT OUR STORE FOR EVEN MORE GREAT  
STUFF!**

**[WWW.EVERYTHING4LESSSTORE.COM](http://WWW.EVERYTHING4LESSSTORE.COM)**

**COPYRIGHT NOTICE**

**ALL MATERIALS INCLUDING CD/DVD AND PDF  
FILES ARE COPYRIGHTED**

**[WWW.EVERYTHING4LESSSTORE.COM](http://WWW.EVERYTHING4LESSSTORE.COM) VON  
WALTHOUR PRODUCTIONS AND MAY NOT BE  
REPRODUCED, COPIED OR RESOLD UNDER ANY  
CIRCUMSTANCES. YOU MAY HOWEVER MAKE A  
COPY FOR YOUR OWN PERSONAL BACKUP.  
MATERIALS ARE FOR PERSONAL USE ONLY.**

**IF YOU PURCHASED THIS FROM ANYWHERE BUT  
FROM US PLEASE NOTIFY US IMMEDIATELY SO  
THAT WE MAY CHECK IF YOU PURCHASED FROM  
AN AUTHORIZED RESELLER SO WE CAN LET YOU  
KNOW IF YOU NEED TO RETURN FOR FULL REFUND  
FROM AN UNAUTHORIZED SELLER.**

**THANKS AGAIN AND PLEASE TAKE THE TIME TO  
VISIT OUR STORE.**

**ATTENTION! EVERYTHING ON SALE NOW!!**



**HOT SALE!**

**THIS PAGE COPYRIGHT VON WALTHOUR PRODUCTIONS  
[WWW.EVERYTHING4LESSSTORE.COM](http://WWW.EVERYTHING4LESSSTORE.COM)**