

# ALIGNMENT PROCEDURE

- OUTPUT METER** ..... Connect Output Meter across speaker voice coil terminals.
- OUTPUT LEVEL** ..... Attenuate Test Oscillator output always to maintain 0.5 volt on Output Meter to prevent overloading of the receiver.
- TEST OSCILLATOR** ..... Modulate Test Oscillator at 400 c/s and connect the earth lead wire of Test Oscillator output to receiver chassis board. Adjust the output of Test Oscillator so as to read the output of the radio receiver at around its maximum volume.
- FREQUENCY ALIGNMENT** ..... Frequency to be aligned and distance on the dial scale of the radio receiver are indicated in the table below.

## FREQUENCY & DISTANCE ON DIAL SCALE

MW Band		SW Band (H)		SW Band (J)	
600 KC	16.7 mm	4 MC	11.5 mm	7 MC	21.3 mm
1500 KC	84.4 mm	11 MC	83.9 mm	16 MC	80.0 mm

**TABLE**

Step	Band Switch Position	Test Oscillator		Radio Receiver	
		Connection to radio receiver	Dial setting	Dial setting	Adjusting to maximum output
1		"ANT" terminal in series with 0.1MFD	455 KC	Quiet point	Top screws of IF transformers
2	MW	Use radiation loop coil (See Fig. 1)	600 KC	600 KC	Screw of MW OSC coil Inductance of MW ANT coil
3			1500 KC	1500 KC	Screw of MW OSC trimmer Screw of MW ANT trimmer
4			600 KC & 1500 KC	600 KC & 1500 KC	Repeat steps (2) and (3).
5			4 MC (H) 7 MC (J)	4 MC (H) 7 MC (J)	Screw of SW OSC coil Inductance of SW ANT coil
6	SW		11 MC (H) 16 MC (J)	11 MC (H) 16 MC (J)	Screw of SW OSC trimmer Screw of SW ANT trimmer
7			4 MC & 11 MC 7 MC & 16 MC	4 MC & 11 MC 7 MC & 16 MC	Repeat steps (4) and (5).
8	MW	"ANT" terminal in series with 0.1MFD	455 KC	Quiet point	(Adjusting to minimum output) Screw of sub ANT coil
9	Check if the above dial settings for SW bands are not made at image frequencies.				

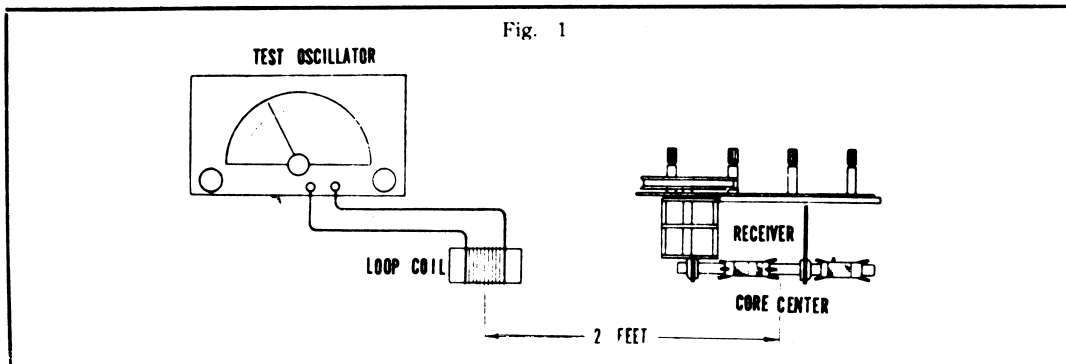

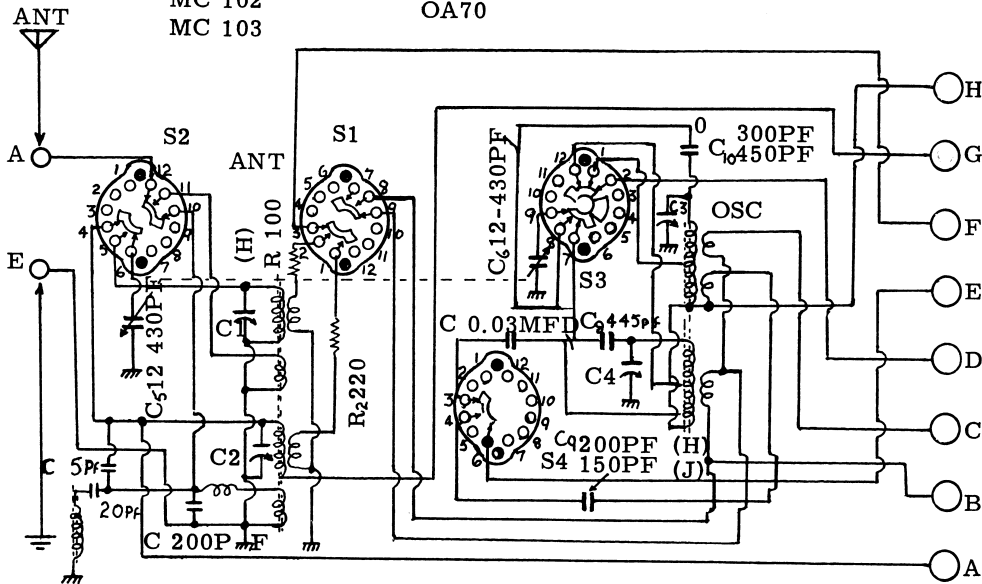
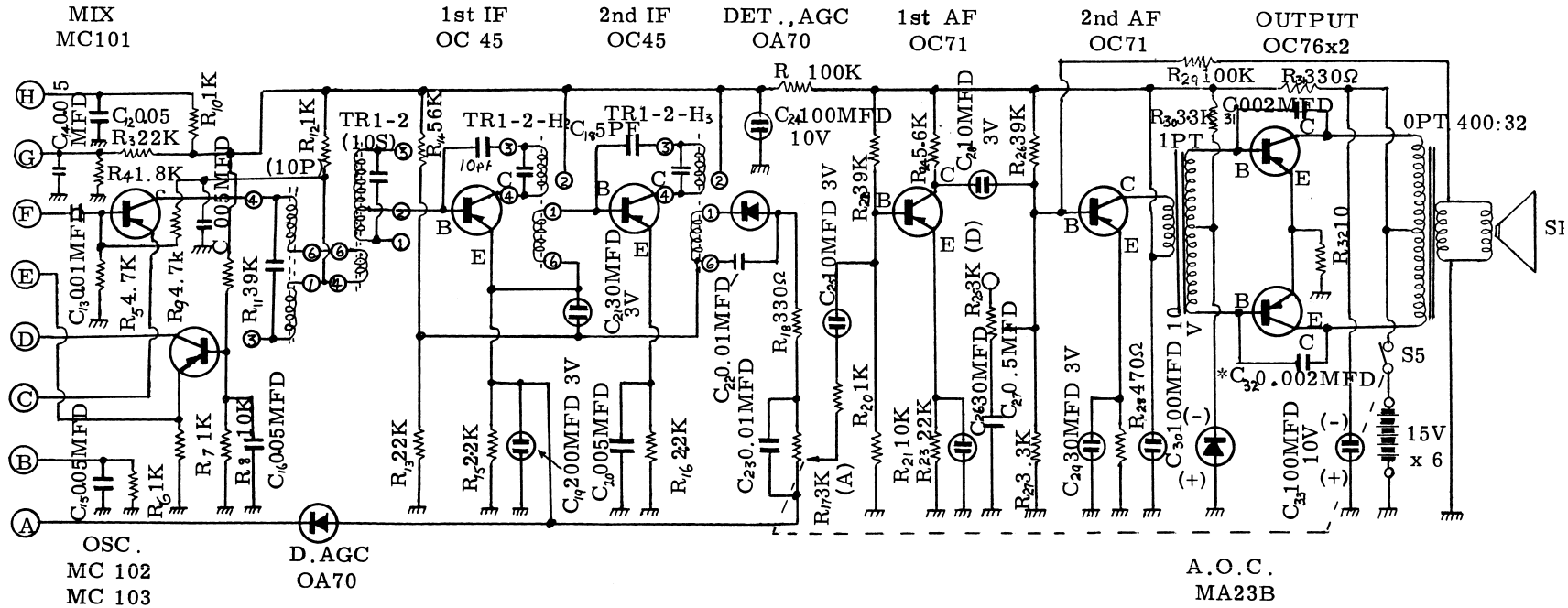

NATIONAL MODEL DB-

421