

Account

Recd. 1 1 MAY 1954

Answered

Invoice No.

SERVICE DATA

PHILIPS RECORD CHANGER

TYPE AG1000

(Read in conjunction with 2974 and 2508 sheets)

The basic functioning of the AG1000 unit is the same as that of the 2974 and 2508 units. For a detailed description of the principles of operation refer to the 2974 sheet. The variations in operation introduced by the three-speed feature are covered in the 2508 sheet. Any variations associated with this unit are given below.

The principles of operation of the changer are also covered in "Service Notes" Issue No. 6, where also is given information on fault-finding, adjustments and repairs.

RECORD SPINDLE SETTING.

The automatic playing record spindle which is basically the same as that used with 2974 and 2508 units, incorporates a minor change. Portion of the inner or moving part, just at the ledge position, has been machined off. This now overcomes one previous fault, that of records being caught momentarily on the spindle and dropping late.

Because of this alteration it is possible to dispense with bracket 24 (Fig. 8, 2974 unit) and it has been done in this unit. The modified spindle can be used on the earlier units without any changes.

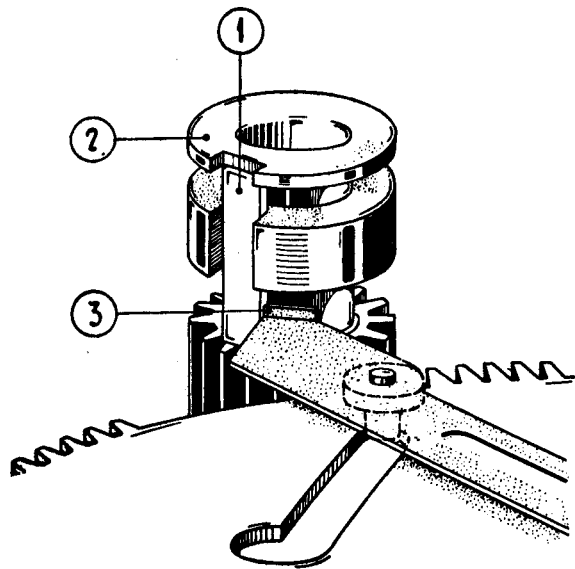

PICK-UP HEAD.

This unit is fitted with the dual sapphire stylus pick-up head type AG3010.

DRIVE PULLEY FOR 40 C/S OPERATION.

If it is required to operate the changer from 40 c/s mains supply, the drive pulley attached to the motor spindle can be replaced by one designed for the new frequency.

After fitting a 40 c/s pulley it is necessary to adjust the turntable speed by means of a stroboscopic disc on all speeds. As an aid in this regard, when fitting the new pulley, it is approximately in the correct position if the grub screw falls just outside the housing of the motor when the pushing-on pressure is applied.

In adjusting speeds the $33\frac{1}{3}$ r.p.m. position is done first. Speeds are adjusted by movement of the stop brackets for the speed selection handle. When the $33\frac{1}{3}$ r.p.m. speed is correctly set, the intermediate driving wheel should be running in the middle of the respective diameter of the drive pulley. If this is not so, the pulley should be repositioned on the spindle and speed again corrected.

When the $33\frac{1}{3}$ r.p.m. position is correct, the other two speeds can be adjusted by means of their stop bracket position.

REST POSITION OF THE LARGE GEAR WHEEL.

During the playing of a record, it is necessary for the large gear wheel to stay in a positive rest position in order to prevent premature cycling of the changer mechanism. This is performed by means of an indented leaf spring fixed in a bracket to the main frameplate and a roller fitted to the gear wheel. Adjustment of this rest position is detailed below (refer drawing opposite).

Put the mechanism in the rest position. Loosen the mounting screws of the stop bracket which mounts the indented leaf spring. The trip lever assembly on the large gear wheel is now moved as far as possible toward the small gear wheel. By movement of the turntable and the stop bracket, bring the nose (3) of the trip lever to touch the cam (1) on the small gear wheel (2), in the middle of its narrow side as shown in the drawing.

Tighten the mounting screws of the stop bracket and draw the trip lever away so that its nose does not contact the cam.

PARTS LISTS

Description	Code No.	Description	Code No.
PICK-UP ARM ASSEMBLY		SWITCH UNIT	
Pick-up arm	A9.865.76	Switch, complete	A3.181.79
Counterbalance spring	49.947.89	Knob for operating lever	23.951.96
Pick-up flex (bulk)	R.294.KN/OIA	Bracket with roller for pick-up rest	A9.864.38
Swivel casting	49.947.85		
Bolt for above	49.947.94		
Steel ball, $\frac{1}{8}$ " 2 x 12 off	89.205.02		
Wire spring in swivel casting	49.937.93		
TURNTABLE		LARGE GEAR WHEEL ASSEMBLY	
Turntable assembly	49.928.73	Gear wheel assembly	49.928.75
Short manual playing spindle	49.933.34	Spindle for gear wheel	49.936.59
Record spindle	49.925.29	Bush for above	49.936.60
Turntable locking ring	49.922.07	Trip lever assembly	49.928.25
		Spring wire for toothed segment	49.932.96
		Roller for rest position	49.936.70
		Stop bracket with leaf spring for rest position	49.928.29
RECORD OVERARM		SPRING DISC ASSEMBLY (on large gear wheel assembly)	
Overarm complete	49.927.85	Screw assembly	49.926.38
Spring in overarm	49.921.90	Thin washer	49.932.92
Guide spindle for overarm	49.936.80	Plain disc	49.932.10
Steel ball, $\frac{1}{8}$ " 2 x 4 off	89.205.02	Recessed disc	49.932.93
Support pillar for overarm	49.936.78	Spring washer	49.935.64
Ball cage	49.936.79	Lock nut	49.932.12
Clamping ring	49.936.81		
CHANGER MECHANISM		REPEAT MECHANISM ASSEMBLY	
Sliding plate assembly	49.928.23	Repeat knob	23.951.97
Cam bearing roller	P5.515.29	Wire spring (omega shaped)	49.932.29
Tension spring	49.932.38	Compression spring on rod, 2x	49.933.73
		Mounting screw for bracket	49.932.76
SMALL GEAR WHEEL ASSEMBLY		REPEAT TRIP LEVER	
Steel washer	49.929.88	Lever	49.937.95
Ball race cage	23.643.86	Pressure spring	49.936.76
Ball, $\frac{3}{32}$ ", 10x	89.205.01	Fibre plate	49.936.77
Fibre washer	49.931.82		
MOTOR ASSEMBLY		SWITCH BEDDING PLATE	
Drive pulley, 50 c/s	49.938.17	Knob for record diameter slide	23.951.95
Grub screw for drive pulley	49.937.15	Looped spring on record diameter slide	49.935.05
Helical spring in bearing, 2x	49.934.36	Shouldered screw for reject control bar	49.932.28
Plate between helical spring and phosphor bearing, 2x	49.934.35	Leaf spring	49.932.47
Phosphor bronze bearing, 2x	A1.612.00	Trip spring	49.936.85
Felt washer, 2x	49.934.34	Return spring for reject control bar	49.932.48
Bearing housing (four claws), 2x	49.934.29	Locking ring for trip spring	07.892.01
Stator assembly	49.928.31		
Rotor assembly	49.928.35		
Ball bearing, $\frac{1}{8}$ "	89.205.02		
Fibre stop plate	49.934.39		
FRICTION DRIVE AND SPEED CONTROL MECHANISM		GAUGE LEVER (12 in. records)	
Intermediate wheel, complete	49.926.47	Gauge lever	49.932.27
Tension spring for above	49.936.88	Stop spring	49.936.22
Mounting screw, actuating arm to wheel bracket	49.935.96	Wire spring (omega shaped)	49.932.29
Rubber bush between actuating arm and wheel bracket	49.922.26	Shouldered screw for gauge lever	49.932.28
Metal bush between actuating arm and wheel bracket	49.935.97	Spring washer for above	49.922.03
Speed indicator plate	49.936.91		
Stop brackets for 78 and $33\frac{1}{2}$ r.p.m.	49.936.90		
Leaf spring for 45 r.p.m. stop	49.934.92		
Speed control handle	49.934.94		
Knob for above	23.607.35		
Large omega shaped spring	49.933.54		
		PICK-UP LIFTING PLATE ASSEMBLY	
		Lifting plate assembly	49.927.27
		Tension spring	49.936.84
		STEERING HOOK PLATE	
		Control hook, large	49.928.26
		Control hook, small (for 45 r.p.m. records)	49.927.42
		Spring on tip of small hook	49.241.10
		Screw mounting repeat trip lever	07.802.16
		Spring on knee of small hook	49.935.58
		Return spring for small hook	49.935.00