

Portable Section of AWA Car Radio/Portable 954 Series

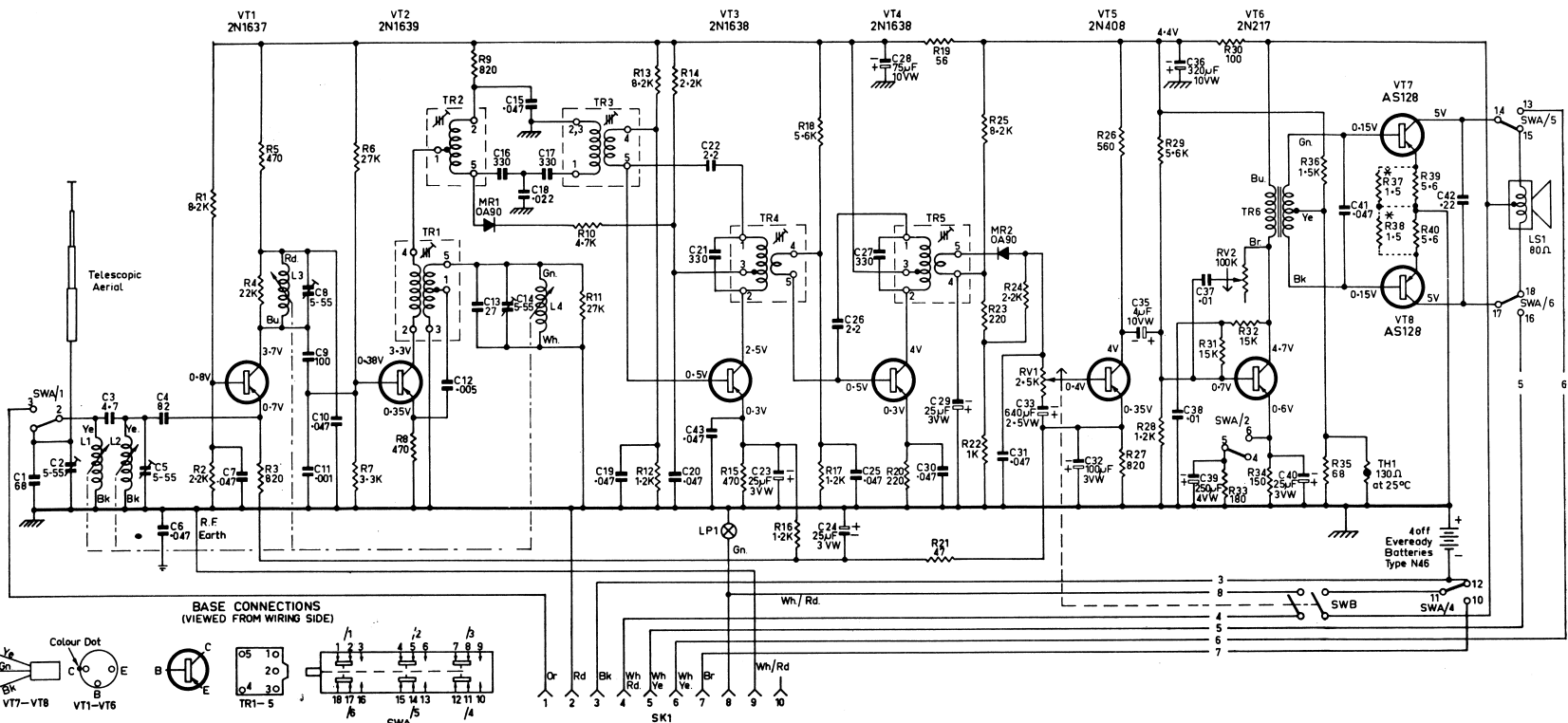

NOTES — (shown in portable position.)

Voltages measured with no signal input with a 20,000 ohm/volt meter.
 Voltages shown are all negative with respect to the positive rail of the printed board and are representative of portable use with 5volts supply.

When use as a 6 volt car radio voltages will be about 10% higher, for 12volts use about 20% higher.

C.R.1083

* R37 and R38 replace R39 and R40 in models 955A and 956A.

R41 a 6.8K ± 10% ½ watt IRC resistor 611526 has been added in parallel with R36.