

The above sensitivity figures indicate the input, which when modulated 30% at 400 c.p.s. provides an audio frequency output of 22.5 volts measured between chassis and the plate of V5 through a series condenser of 0.1 MFD. Volume control must be turned to maximum. When measuring sensitivity a 0.1 MFD condenser should be used between the "HOT" signal generator lead and the grid of the valve (stage) being checked. Do not disconnect any wiring.

#### ALIGNMENT FREQUENCIES:

R.F. coil 600 Kc/s and 1400 Kc/s.  
Rod Aerial Coil, 570 Kc/s and 1400 Kc/s.

#### CHECK POINT:

1000 Kc/s.

#### ADDITIONAL INFORMATION:

**FERRITE ROD AERIAL:** The material is of a ceramic nature and is extremely fragile. Care should be used in handling to avoid fracture. If realignment of this component is necessary the signal generator should be connected as shown and its output adjusted to give a readable voltage on the output meter.

A signal at 1400 Kc/s should be tuned to maximum by means of the aerial trimmer condenser.

At 570 Kc/s. the aerial rod winding should be moved along the rod to give maximum deflection of the output meter. Repeat alignment at 1400 Kc/s. with trimmer and again at 570 Kc/s. by sliding the coil until no further improvement can be obtained. Seal with a small amount of suitable lacquer to prevent future movement.

**MODULATION HUM:** If, after major repairs to the receiver, modulation hum is present, it may be minimised by movement of the hum neutralising plate fitted for this purpose. This plate is factory sealed and normally should not require re-setting. However, if adjustment is required, it may be carried out by removing the self-tapping holding screw and unsoldering the plate. With the receiver operating on the A.C. supply and loosely coupled to a signal generator, apply a strong unmodulated signal. Adjust the position of the plate for minimum hum, reversing the plate if necessary; then tighten holding screw and re-seal with a small quantity of solder.

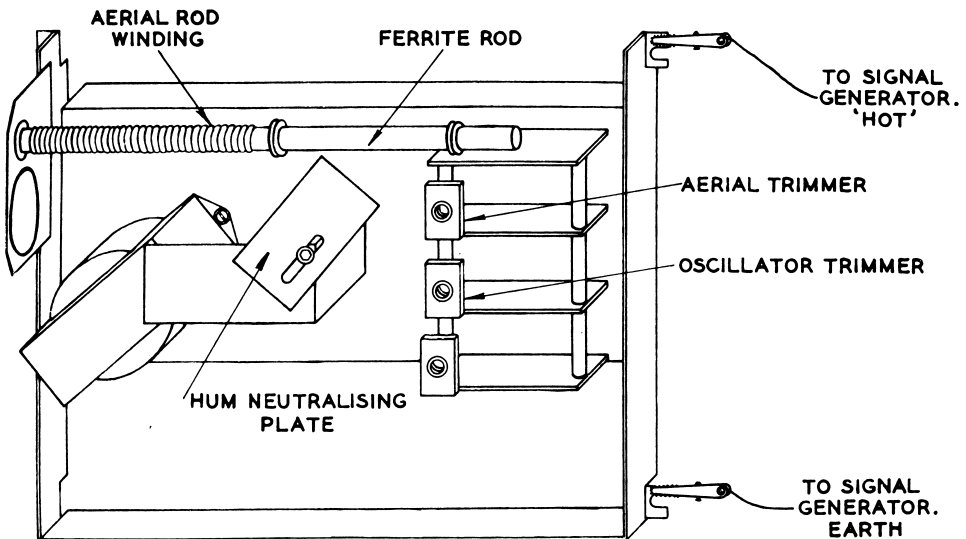

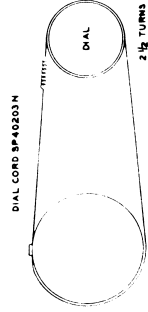
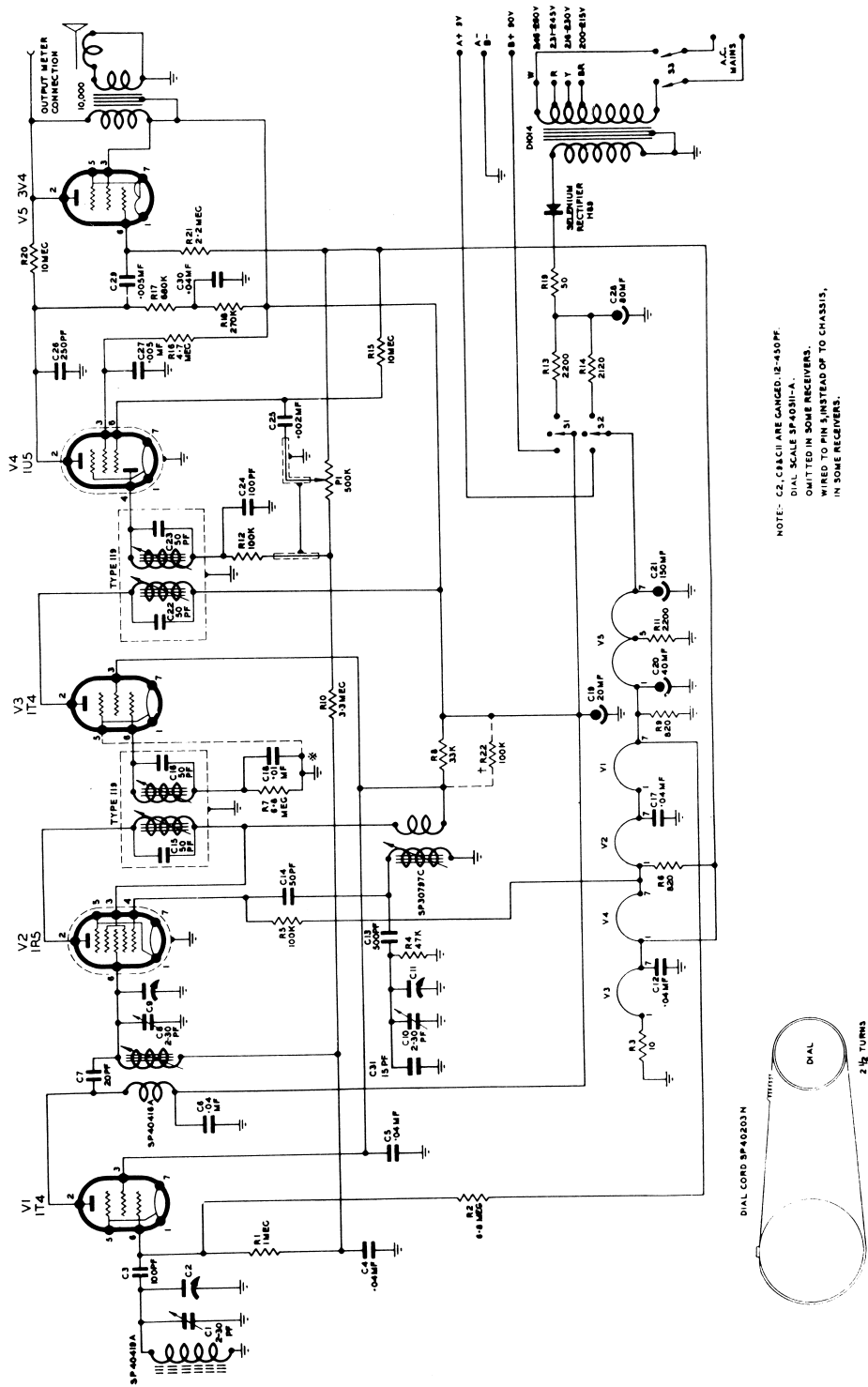

# SPECIFICATION OF S.T.C. MODEL 5142 S51.

## DESCRIPTION:

A five valve A.C. or battery operated portable receiver, incorporating:—  
 Inbuilt Ferrite Rod Aerial.  
 Isolating power transformer for A.C. operation.  
 Selenium rectifier.  
 Automatic Volume Control.  
 Three position selector switch for "A.C.-OFF-BATT."

## TUNING RANGE:

530-1620 Kc/s.

## INTERMEDIATE FREQUENCY:

455 Kc/s.

## VALVE COMPLEMENT:

- V1 R.F. Amplifier. IT4.
- V2 Frequency Converter. IR5.
- V3 I.F. Amplifier. IT4.
- V4 Detector, A.V.C. and Audio Amplifier. IU5.
- V5 Power Output Pentode. 3V4.

## POWER SUPPLY:

200-260 volts, 40-60 cycles, A.C.  
 90 milliamps, at 240 volts, 50 cycles input.  
 "A" battery, 9 volts at 50 milliamps.  
 "B" battery, 90 volts at 12 milliamps approx.

## LOUD SPEAKER:

Four inch permagnetic with 10,000 ohm transformer.

## CIRCUIT VOLTAGES:

	Plate	Screen	Filament A.C. Operation	Filament Bat. Operation
V1	90	36	1.25 to 1.45 (Pins 1 to 7)	1.25 to 1.55 (Pins 1 to 7)
V2	36	36	1.25 to 1.45 (Pins 1 to 7)	1.25 to 1.55 (Pins 1 to 7)
V3	90	36	1.25 to 1.45 (Pins 1 to 7)	1.25 to 1.55 (Pins 1 to 7)
V4	90 thru 950K	90 thru 4.7 meg.	1.25 to 1.45 (Pins 1 to 7)	1.25 to 1.55 (Pins 1 to 7)
V5	87	90	1.25 to 1.45 (Pins 1 to 5)	1.25 to 1.55 (Pins 1 to 5)
V5			1.25 to 1.45 (Pins 5 to 7)	1.25 to 1.55 (Pins 5 to 7)

These voltages may vary within 5% of their stated values and must be measured with a voltmeter having a resistance of at least 1000 ohms per volt. Plate and Screen volts should be measured to receiver earth, but filament readings must be taken across each individual filament.

## MEASUREMENT SPECIFICATION:

- I.F. Sensitivity—V2 grid—100 microvolts.
- I.F. Sensitivity—V3 grid—5.3 millivolts.
- Broadcast Sensitivity—V1 grid—10 microvolts.