

MODEL 5132

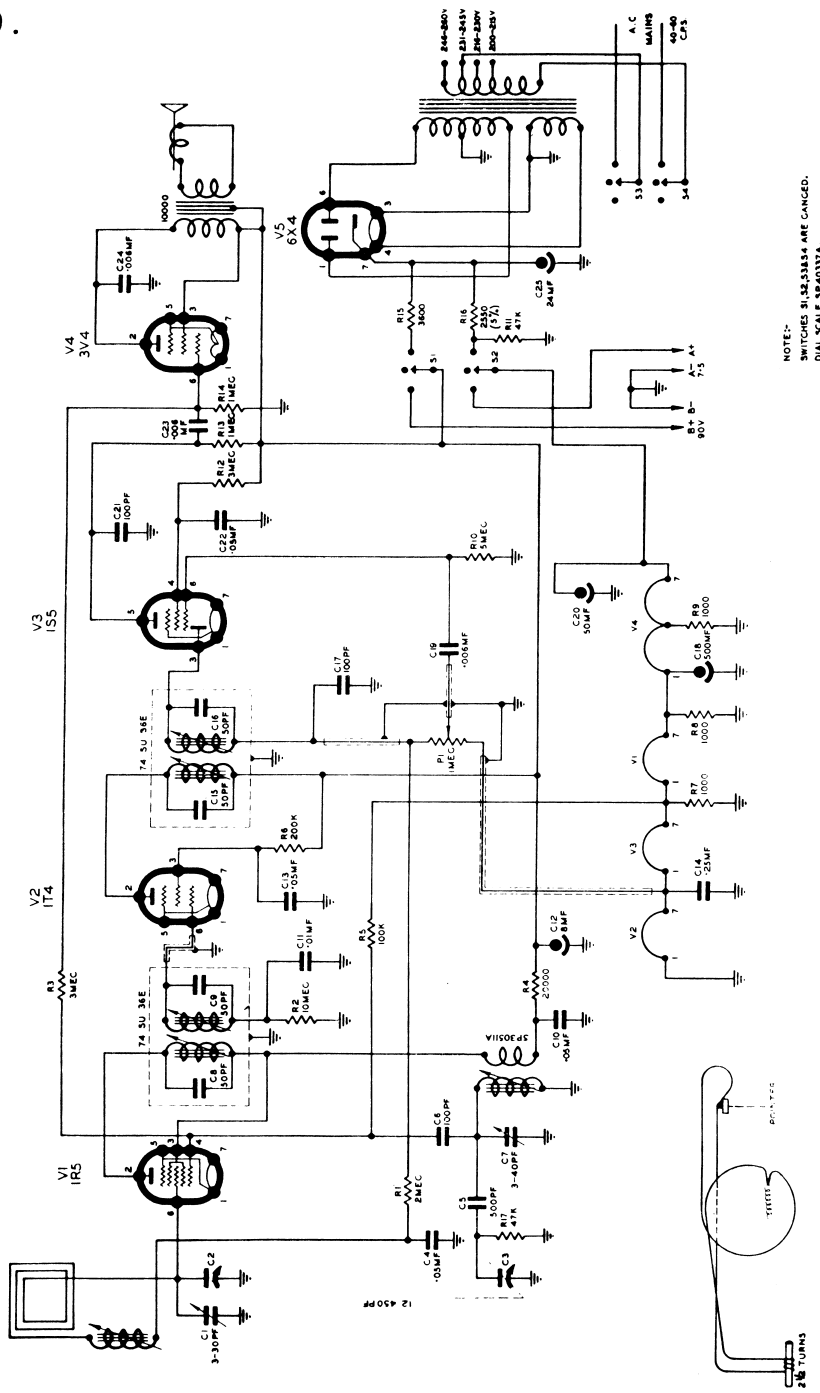

NOTES:
SWITCHES S1, S2, S3, S4 ARE GANGED.
DIAL SCALE SP-40337A.

DIAL CORD DETAIL
GANG CONDENSER FULLY MES-ED

SPECIFICATION OF S.T.C. MODEL A5132

DESCRIPTION:

A 5 valve A.C. or 4 valve battery operated portable receiver incorporating—
Isolating Power Transformer for A.C. operation.
Automatic Volume Control.
Three position Selector Switch for "Battery. Off. A.C."
Inbuilt Loop Aerial.

TUNING RANGE:

530-1620 Kc/s.

INTERMEDIATE FREQUENCY:

455 Kc/s.

VALVE COMPLEMENT:

- V1. Frequency Converter. 1R5.
- V2. I.F. Amplifier. 1T4.
- V3. Detector, AVC and Audio Amplifier. 1S5.
- V4. Power Output Pentode. 3V4.
- V5. HT Rectifier. 6X4.

POWER SUPPLY:

200-260 volts, 40-60 cycles A.C.
85 Milliamps at 240 volts 50 cycles Input.
"A" Battery 7.5 volts at 50 Milliampers.
"B" Battery 90 volts at 11 Milliampers.

LOUD SPEAKER:

5 inch Permagnetic with 10,000 Ohm Transformer.

CIRCUIT VOLTAGES:

	Plate	Screen	Cathode	Heater
V1	50	50	—	3.9
V2	90	36	—	1.3
V3	90 thru .5 Meg.	90 thru 3 Meg.	—	2.6
V4	87	90	—	6.5
V5	136/136	—	130	6.2

These voltages may vary within 5% of their stated values and must be measured to receiver earth with a voltmeter having a resistance of at least 1000 ohms per volt. Volume control must be turned to maximum.

MEASUREMENT SPECIFICATION:

I.F. Sensitivity—V1 grid 80 Microvolts.
I.F. Sensitivity—V2 grid 4 Millivolts.
Broadcast Sensitivity. V1 grid, 100 Microvolts average.
These figures are related to an audio frequency output of 22.5 volts measured between plate of V4 and EARTH through a series condenser of .1 MFD capacity.
When measuring the above sensitivities, a .1MF condenser should be used between the "HOT" signal generator lead and grid of V1.
Do not disconnect any wiring.

ALIGNMENT FREQUENCIES:

600 Kc/s and 1400 Kc/s.

CHECK POINT:

1000 Kc/s.