

PHILIPS RADIOPLAYER

MODELS 199A-C

Note: Models 199A-C differ in tuning capacitor, tuning knob, cursor, cursor spring and dial scale.

SPECIFICATIONS

(Subject to alteration without notice)

Tuning Range	530—1620 Kc/s.
Intermediate Frequency	455 Kc/s.
Power Supply — Battery	9V Type 276P
Battery Consumption	12mA without signal 31mA for 50mW output

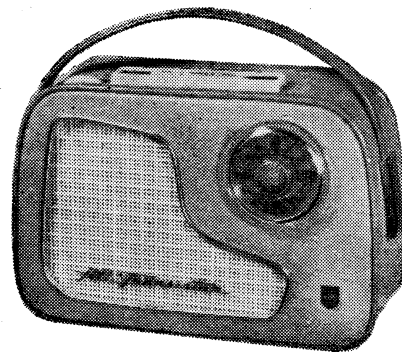

TRANSISTOR EQUIPMENT AND VOLTAGE/CURRENT ANALYSIS

Transistor Function	Transistor No.	Transistor Type	Collector		Base Volts	Emitter Volts
			Volts	mA		
Frequency Converter	TR1	OC170	6.2	0.35	0.95	0.8
1st I.F. Amplifier	TR2	OC169	5.4	0.75	1.7	1.5
2nd I.F. Amplifier	TR3	OC169	7.1	0.9	1.1	0.9
1st Audio Amplifier	TR4	OC71	6.8	0.5	1.8	1.6
2nd Audio Amplifier	TR5	OC71	8.4	2.1	2.5	2.36
Push-Pull Audio Amplifier	TR6	OC74	9	5.5*	0.26	0
Push-Pull Audio Amplifier	TR7	OC74	9		0.26	0
A.V.C.	D1	OA79	Germanium diode			
Demodulator	D2	OA79	Germanium diode			

*Combined current of TR6, TR7

Voltages measured with a "20,000Ω per volt" meter on the 10V range

PRE-SET BIAS ADJUSTMENT.

Correct bias for TR6 and TR7 is achieved by adjustment of potentiometer R27 which is chassis mounted directly behind the speaker. An access hole in the chassis, directly beneath the potentiometer, facilitates screwdriver adjustment from the rear of the receiver. Set the volume control to the minimum position, and adjust R27 to achieve a combined TR6, TR7 collector current of 5.5mA.

NOTE: It is desirable to operate the receiver for approximately 3 minutes before checking TR6, TR7 current.

REPLACEMENT OF VOLUME CONTROL KNOB

Remove chassis from case (see "To remove chassis from case"). Unscrew hexagonal securing nut and withdraw potentiometer from mounting bracket, at the same time extract knob from the potentiometer spindle (push fitted).

PUSH-BUTTON SWITCH REPLACEMENT.

To replace the push-button switch, remove chassis from case (see "To remove chassis from case") and release switch from mounting brackets (2 screws). Only the complete switch unit is available as a service replacement. Access to the switch contacts is through a cut-out in the front plate.

REPLACEMENT OF SWITCH ESCUTCHEON.

The switch escutcheon is secured to the case by two screws, the heads of which are concealed by two decorative plates. Before securing the screws, adjust escutcheon to ensure free travel of the push-buttons. The decorative plates are attached after final assembly by adhesion. Removal of rod aerial from the supporting brackets allows access to the screws inside the case.

TO REMOVE SPEAKER FROM CHASSIS.

Remove two screws, one each side of lug strip cut-out in front plate. Remove screw situated bottom corner (securing front plate, speaker, chassis and utilising a spacer). Release screw securing gang support bracket to front plate. Unsolder speaker leads (black lead at lug strip and green lead at chassis). Detach speaker mounting brackets (3 off).

With the receiver face down, raise the chassis sufficiently to clear the speaker magnet, then withdraw speaker from the front plate.

ALIGNMENT.

Because of the compactness of this receiver, it is necessary to remove the chassis from the case, when re-alignment is necessary (see "To remove chassis from case").

I.F. Alignment.

With volume control at maximum, tone control at treble and gang in open position (minimum capacity), apply a 455 kc/s signal through a 0.1μF capacitor to TR1 base.

Detune L3, L4 and L9 by screwing slugs out one turn.

Connect a 20pF capacitor between pin 8 of L7 and chassis.

Peak L8.

Transfer capacitor to pin 4 of L8 and chassis.

Peak L7 and L9.

Transfer capacitor to pin 8 of L7 and chassis.

Peak L4.

Transfer capacitor to pin 4 of L4 and chassis.

Peak L3.

Do not readjust iron cores.

(Continued on Back Page).

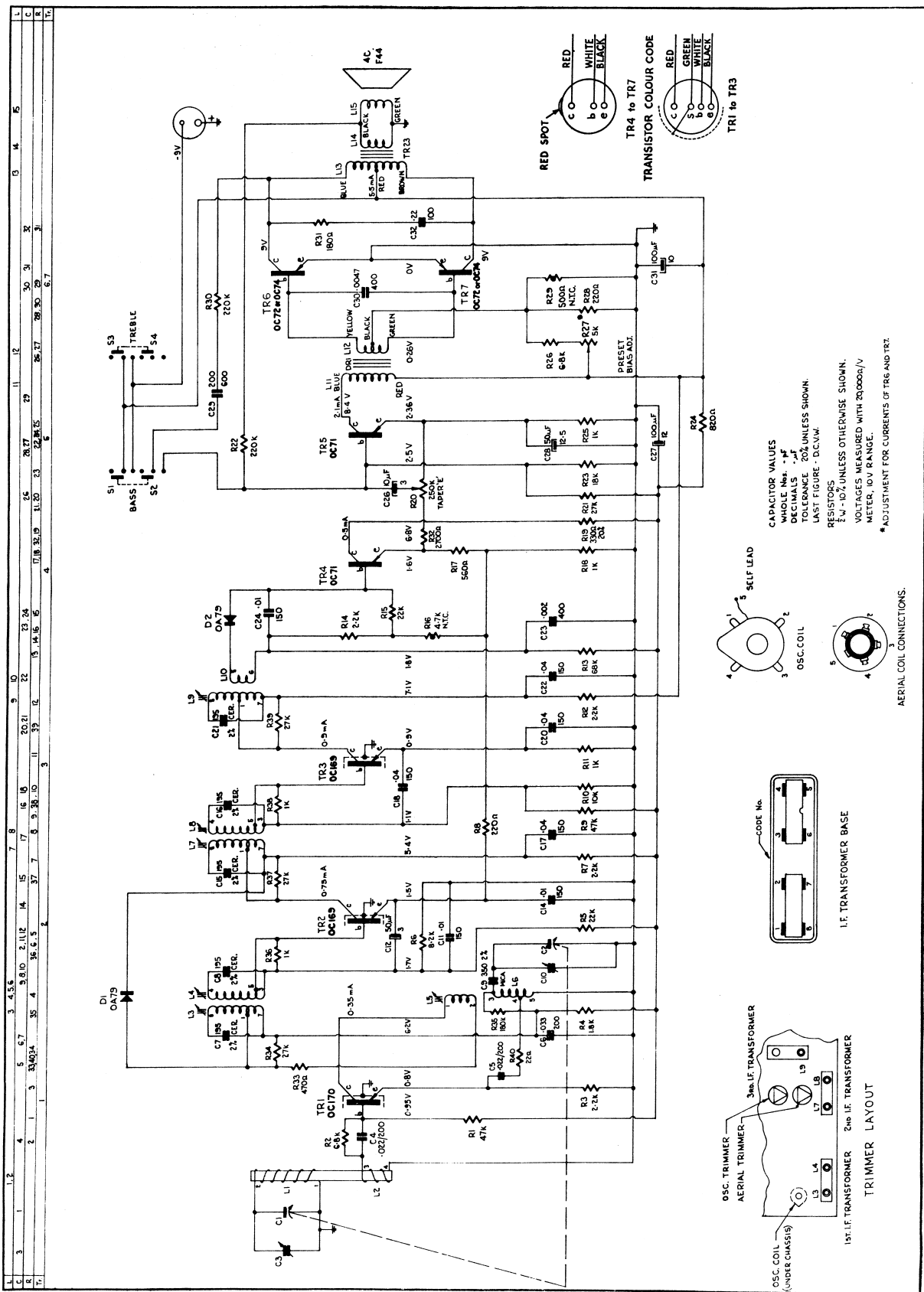

PARTS LIST

CAPACITORS

No.	Description	Code No.
C1, 2	2 gang tuning capacitor (199C)	CZ.107.767
	2 gang tuning capacitor (199A)	CZ.107.771
C3, 10	30pF air trimmer	CZ.113.700
C4, 5	0.022 μ F 200V paper	
C6	0.033 μ F 200V paper	
C7, 8, 15, 16, 21	Part of I.F. transformers	
C9	350pF \pm 2% mica	
C11, 14, 24	0.01 μ F 150V paper	
C12, 28	50 μ F 12.5V electrolytic	AC.5713/50
C17, 18, 20, 22	0.04 μ F 150V paper	
C23	0.002 μ F 400V paper	
C26	10 μ F 3V electrolytic	AC.5710/10
C27	100 μ F 12.5V electrolytic	AC.5713/100
C29	200pF 600V paper	
C30	0.0047 μ F 400V paper	
C31	100 μ F 10V electrolytic	
C32	0.22 μ F 100V paper	

All tolerances are \pm 20% unless otherwise specified.

RESISTORS

No.	Description	Code No.
R1, 9	4,700 Ω $\frac{1}{2}$ W carbon	
R2	6,800 Ω $\frac{1}{2}$ W carbon	
R3, 7, 12, 14	2,200 Ω $\frac{1}{2}$ W carbon	
R4	1,800 Ω $\frac{1}{2}$ W carbon	
R5, 15	22,000 Ω $\frac{1}{2}$ W carbon	
R6	8,200 Ω $\frac{1}{2}$ W carbon	
R8, 28	220 Ω $\frac{1}{2}$ W carbon	
R10	10,000 Ω $\frac{1}{2}$ W carbon	
R11, 18, 25, 36, 38	1,000 Ω $\frac{1}{2}$ W carbon	
R13	68,000 Ω $\frac{1}{2}$ W carbon	
R16	4,700 Ω 20% $\frac{1}{2}$ W N.T.C.	B8.320.07P/4K7
R17	560 Ω $\frac{1}{2}$ W carbon	
R19	330 Ω 20% $\frac{1}{2}$ W carbon	
R20	250,000 Ω carbon potentiometer	CZ.034.002
R21, 34, 37, 39	27,000 Ω $\frac{1}{2}$ W carbon	
R22, 30	220,000 Ω $\frac{1}{2}$ W carbon	
R23	18,000 Ω $\frac{1}{2}$ W carbon	
R24	820 Ω $\frac{1}{2}$ W carbon	
R26	6,800 Ω $\frac{1}{2}$ W carbon	
R27	5,000 Ω carbon potentiometer (pre-set)	CZ.034.004
R29	500 Ω 20% 1W N.T.C.	B8.320.01P/500E
R31	180 Ω $\frac{1}{2}$ W carbon	
R32	2,700 Ω $\frac{1}{2}$ W carbon	
R33	470 Ω $\frac{1}{2}$ W carbon	
R35	180,000 Ω $\frac{1}{2}$ W carbon	
R40	22 Ω $\frac{1}{2}$ W carbon	

All tolerances are \pm 10% unless otherwise specified.

INDUCTORS

No.	D.C. Resistance Ohms	Description	Type or Code No.
L1	1.1-1.3	Rod aerial assembly	CZ.323.040
L2	<0.5		
L3	5.0-6.0	1st I.F.T.	CZ.320.460
L4	5.0-6.0		
L5	2.2-2.8	Oscillator coil	CZ.330.619
L6	1.1-1.3		
L7	5.1-6.3	2nd I.F.T.	CZ.320.461
L8	5.1-6.3		
L9	5.0-6.0	3rd I.F.T.	CZ.320.462
L10	1.3-1.6		
L11	275 } 95 }	Driver transformer	Type DR1
L12			CZ.345.823
L13	7.7-9.4	Output transformer	Type TR23
L14	<0.5		CZ.345.059
L15		Speaker	Type 4C-F44

IMPORTANT! When ordering spare parts, quote CODE NUMBER of part and MODEL NUMBER of Receiver. In claiming free replacement under GUARANTEE, return defective part PROMPTLY and quote MODEL and SERIAL NUMBER of Receiver and DATE OF PURCHASE.

MISCELLANEOUS COMPONENTS

Description	Code No.	Description	Code No.
Badge	CR.531.433	Knob, tuning (199C)	CR.523.510
Bracket, aerial support, R.H.	CS.231.264	Knob, tuning (199A)	CR.523.531
Bracket, aerial support, L.H.	CS.231.263	Knob, volume	CR.523.504
Bracket, potentiometer mounting	CS.229.640	Plate, handle securing, x2	CS.241.730
Bracket, switch mounting, x2	CS.233.573	Plate, trim, switch escutcheon mounting screws, x2	CS.430.952
Bracket, speaker mounting, x3	CS.233.591	Name, Philips	CS.436.459
Case, leather, luggage brown	CR.572.550	Scale, dial (199C)	CS.412.423
Case, leather, atmosphere grey	CR.572.555	Scale, dial (199A)	CS.412.445
Case, leather, spring fever red	CR.572.556	Shield, chassis	CS.420.422
Clip, grille trim	CS.430.050	Spring, I.F.T. mounting, x3	A3.652.58
Cover, handle end, x2	CS.430.410	Spring, cursor securing (199C)	CS.211.032
Cursor (199C)	CS.410.648	Spring, cursor securing (199A)	CS.211.037
Cursor (199A)	CS.410.659	Spacer, chassis to front plate	CS.213.292
Escutcheon, switch	CS.430.049	Speed fix, chassis securing	CH.629.059
Foot, case, x4	CS.240.033	Strip, insulating	CS.115.209
Grille, moulded (front)	CS.430.955	Strip, chassis securing, x2 (attach to case)	CS.470.272
Grille, moulded (rear)	P5.350.26/159	Switch, complete, push-button unit	A3.791.13
Handle, luggage brown	CR.523.419	Trim, grille	CS.430.956
Handle, atmosphere grey	CR.523.420	Trim, handle cover decorative, x2	CS.430.052
Handle, spring fever red	CR.523.421	Wordmark "All Transistor"	CS.436.453

R.F. Alignment.

Location of R.F. trimmers is shown as an inset to the circuit diagram. Small indentations in receiver front plate represent alignment calibration markers. The marker directly below gang spindle is the gang closed position. Proceeding in an anti-clockwise direction, the 600 kc/s and 1420 kc/s markers follow. The existing cursor, if inverted on the tuning capacitor spindle, will make a satisfactory reference pointer.

Position receiver on bench with the speaker facing upward and place rod aerial in position as near as possible to its permanent posture in case. With the gang in closed position, adjust the cursor to the stop position marker. Set volume control to maximum, tone to treble position and connect generator through a series network comprising an 0.1 μ F capacitor and 5,000 Ω resistor to lug 3 of rod aerial.

Alignment frequencies are:—

600 kc/s peak oscillator coil slug, whilst rocking gang.

1420 kc/s peak oscillator and aerial trimmers.

Repeat above trimming procedure.

TO REMOVE CHASSIS FROM CASE

Remove tuning knob (push fit). Detach the cursor from the tuning capacitor spindle with the assistance of long-nose pliers. Remove battery pack. Detach handle decorative cover plates (pull out at bottom and slide upward to release) and unscrew chassis retaining screws (one each side of case). Release rod aerial from mounting brackets. Carefully lower the chassis as far as possible and withdraw the bottom section until the switch buttons and volume control knob are clear. Whilst withdrawing the chassis care should be exercised to ensure damage-free extraction of the switch buttons from the switch escutcheon.

Re-insertion is a reversal of the above method: however, when replacing retaining screws, hold chassis firmly against case front and top. Before final assembly, check tuning gang spindle concentricity with dial scale and ensure free movement of push-buttons and volume control knob in their respective cavities.



Published by

Philips Electrical Industries Pty. Limited

Sydney — Newcastle — Melbourne — Brisbane — Adelaide — Perth — Hobart