

MISCELLANEOUS COMPONENTS

No. on Dial Cord Layout Drawing	Description	Code No.	No. on Dial Cord Layout Drawing	Description	Code No.
7	Assembly, cursor	CR.480.662	—	Clip, spring (I.F.T. mtg.), 2x	A3.652.58
—	Assembly, lampholder	CZ.367.920	4	Cord, dial drive	37" of cord required
—	Badge, Philips	CS.436.425	1	Drum, dial	CS.359.806
—	Bracket, cabinet back mtg, 3x	CS.244.602	—	Knob, control, 2x	CR.523.711
—	Bracket, cabinet back mtg, 3x	CS.244.602	—	Prism, dial scale	23.678.74
—	Cabinet, with grille and badge—		5	Pulley, dial	CS.359.602
	Blue	CR.570.556	6	Ring, dial cord	CS.281.807
	Burgundy	CR.570.555	—	Scale, dial	CS.412.393
	Green	CR.570.557	—	Screw, dial scale mtg., 2x	CS.258.852
	Ivory	CR.570.554	3	Spindle, tuning	CS.351.358
	Walnut	CR.570.553	2	Spring, dial drum	CS.210.029
			—	Spring, knob retaining, 2x	CS.281.832

*DIAL CORD LAYOUT.
VIEW FROM FRONT OF CHASSIS.*

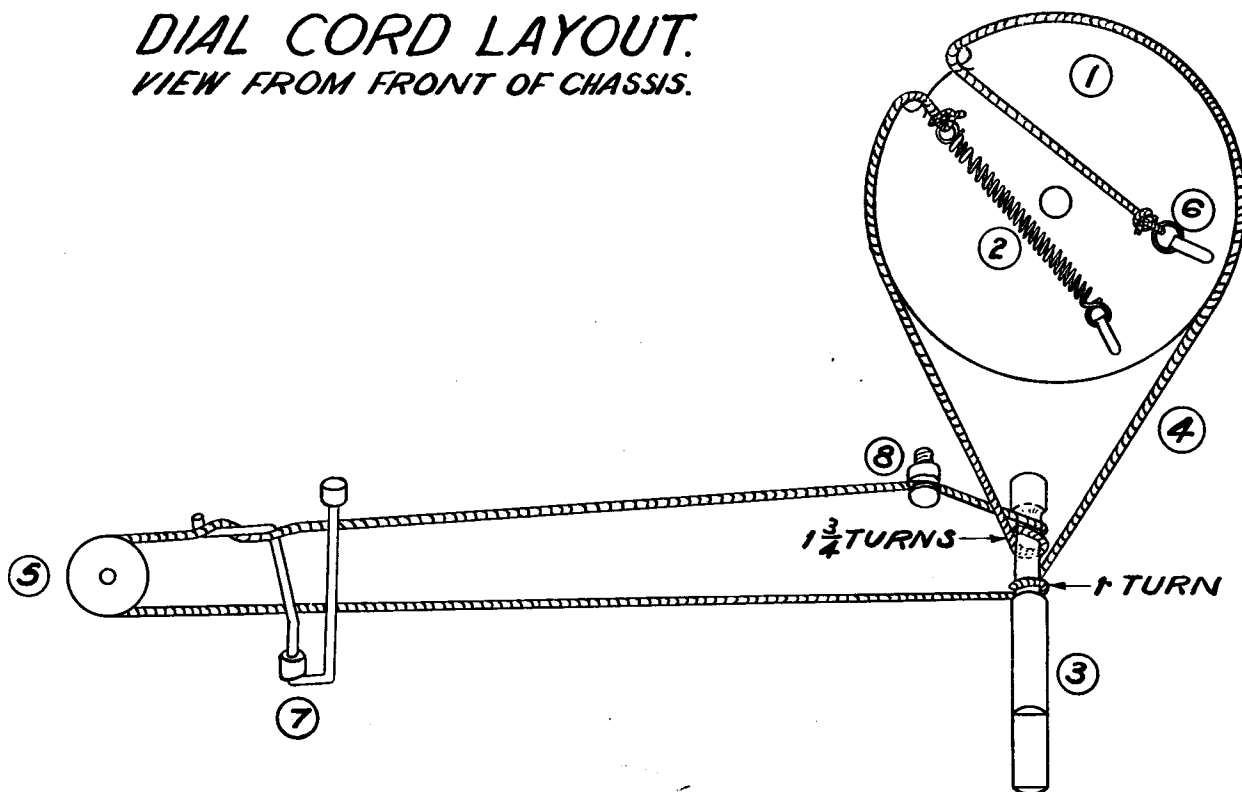

PHILIPS RADIOPLAYER

MODEL 164

SPECIFICATIONS

(Subject to alteration without notice)

Power Supply	200-250V, 40-50 c/s.
Tuning Range	530-1620 kc/s.
Intermediate Frequency	455 kc/s.
Cabinet	Bakelite mantel

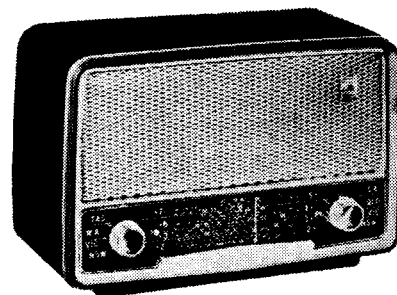

VALVE EQUIPMENT AND VOLTAGE ANALYSIS

Valve Function	Valve No.	Valve Type	Plate Volts	Screen Volts	Osc. P. Volts
Frequency Converter	V1	6AN7	210	55	55
I.F. Amplifier, Demodulator and A.V.C.	V2	6N8	210	55	—
Power Amplifier	V3	6M5	208	210	—
Rectifier	V4	6V4	V4 cathode — L13 C.T., 232V.		
Dial Lamp	V11	6.3V, 0.32A tubular screw			
Voltage across R13, -6.7V					

NOTE: These voltages are measured with an "1,000 ohms per volt" meter and may vary $\pm 10\%$ from the figures quoted. They are measured from the socket points indicated to chassis, or across the resistor listed. The receiver should be in a "no signal" condition.

TO REMOVE CHASSIS FROM CABINET.

Remove the power plug from the wall outlet socket. Pull the control knobs from their spindles. Remove the combined cabinet back and bottom cover. Unsolder the speaker voice coil connections from the lug strip alongside the output transformer. Unwind the dial cursor from the dial drive cord.

The chassis is held to the cabinet by two screws at the rear. Removal of the two screws and the associated mounting brackets and packing pieces allows the chassis to be withdrawn from the cabinet, leaving speaker and dial scale in the cabinet.

The chassis may be replaced by a reversal of the above procedure.

DIAL SCALE REMOVAL.

The dial scale is removed from the front of the cabinet. The control knobs must first be removed. In removing the two dial scale securing screws, care must be used to ensure that damage is not caused to the scale by tools. The best tool to use is a 9/32" spintite blinded off so that its face does not touch the scale.

ALIGNMENT.

By making use of short length tools, alignment can be undertaken with the chassis in the cabinet.

I.F. transformer adjustments are:—

2nd I.F.T.—

Secondary — front screw

Primary — rear screw

1st I.F.T.—

Secondary — screw nearer 6N8

Primary — screw nearer 6AN7

Before commencing R.F. alignment, fully close the tuning capacitor and set the dial cursor to the stop mark which will be found at the bottom of the dial scale at the low frequency end. Use an 100pF capacitor as dummy aerial for R.F. alignment. Trimming adjustments are: oscillator trimmer (1,420 kc/s, 3XY) front of tuning capacitor, aerial trimmer (1,420 kc/s) rear of tuning capacitor, padding (600 kc/s, 7ZL) iron core in oscillator coil.

In the event of replacement of the oscillator coil, it is advisable to make a preliminary peaking of the iron core at 600 kc/s before commencing alignment. **No attempt should be made to adjust the aerial coil iron core.**

MAINS VOLTAGE ADJUSTMENT

The power transformer is provided with two primary winding tapings—200/230 volts and 240/250 volts—for adjustment of the receiver to the supply voltage at the point of installation. The receiver is adjusted at the factory to the 240/250 volts tapping.

DIAL CALIBRATION ADJUSTMENT.

If dial calibrations are incorrect over the dial scale by an equal amount, the error can be corrected by sliding the cursor on the dial cord to the correct position.

Published by Philips Electrical Industries Pty. Ltd.
Sydney — Melbourne — Brisbane — Adelaide — Perth

L	1	2	12, 13, 14,	3,	4,	5	6	7	8	9,	10,	11
C	1	4,	2	5	3,6,	9,	7	12, 14, 15,	16			
R					1	13		17, 8, 10, 18		12,	14, 15,	
V					1, 4, 11,			12, 2, 3	2	9, 10,	11	

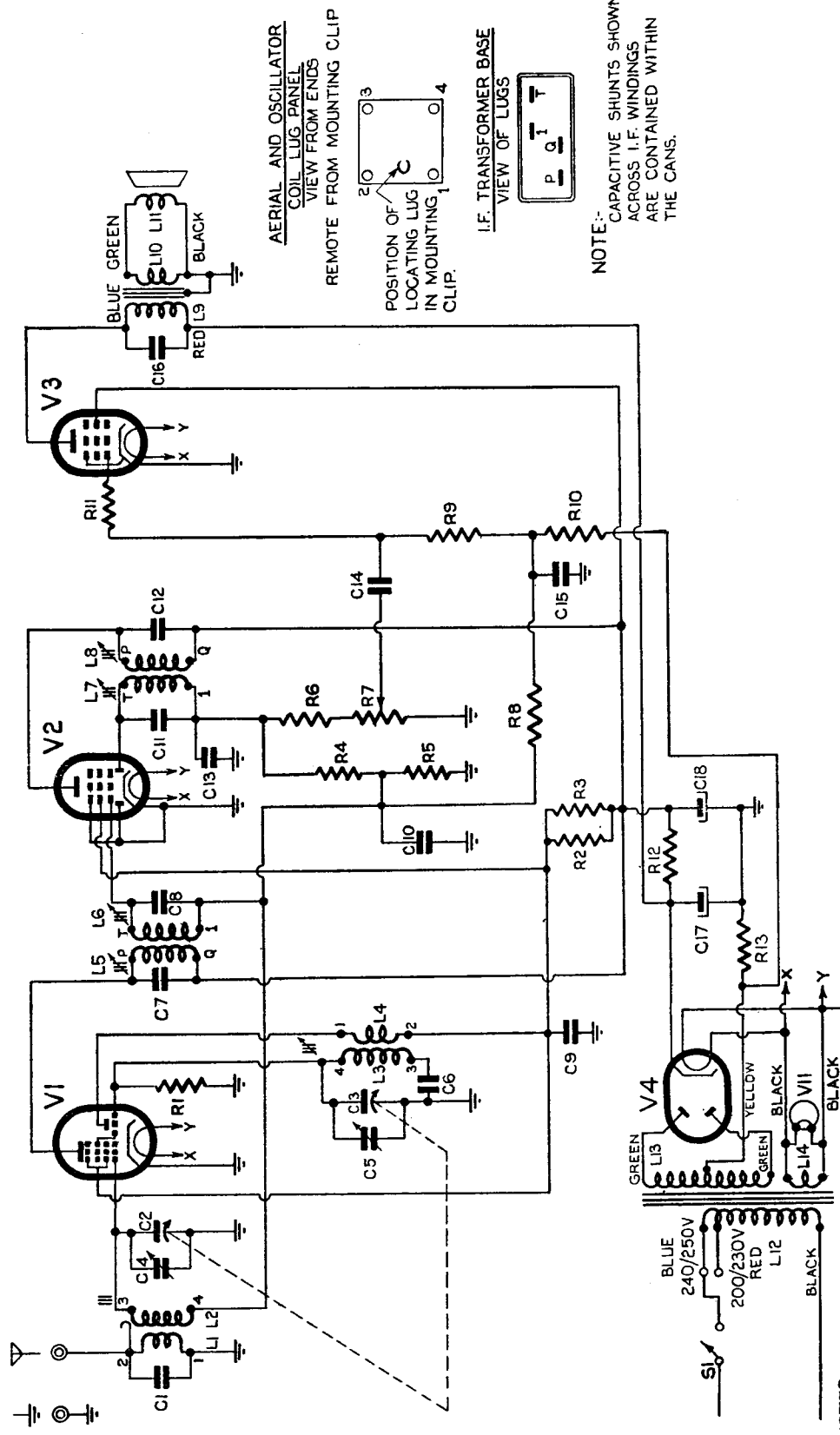

AERIAL AND OSCILLATOR COIL LUG PANEL
VIEW FROM ENDS
REMOTE FROM MOUNTING CLIP

POSITION OF LOCATING LUG IN MOUNTING CLIP.

I.F. TRANSFORMER BASE
VIEW OF LUGS

NOTE:-
CAPACITIVE SHUNTS SHOWN ACROSS I.F. WINDINGS ARE CONTAINED WITHIN THE CANS.

NOTES:-
(i) SWITCH S1 IS MOUNTED ON VOLUME CONTROL (R6, R7).
(ii) R6 IS INCLUDED IN POTENTIOMETER R7.

PARTS LISTS

CAPACITORS

No.	Description	Code No.
C1	100 pF mica	
C2, 3, 4, 5	2 gang tuning and trimmers	CZ.107.749
C6	330 pF mica 2%	CZ.066.124
C7, 8, 11, 12	Part of I.F. transformers	
C9	0.05 mF 400V paper	
C10, 14	0.05 mF 200V paper	
C13	250 pF mica	
C15	0.25 mF 200V paper	
C16	0.01 mF 400V paper	
C17, 18	24 mF 350V electrolytic	

All tolerances are 20% unless otherwise stated.

RESISTORS

No.	Description	Code No.
R1	22,000 ohms $\frac{1}{2}$ W carbon	
R2, 3	47,000 ohms 1W carbon	
R4, 8	2.2 megohms $\frac{1}{2}$ W carbon	
R5	560,000 ohms $\frac{1}{2}$ W carbon	
R6, 7	0.5 megohm carbon potentiometer with stop at 100,000 ohms and S.P.S.T. switch	CZ.032.013
R9, 10	470,000 ohms $\frac{1}{2}$ W carbon	
R11	47,000 ohms $\frac{1}{2}$ W carbon	
R12	1,000 ohms 1W carbon	
R13	160 ohms 1W W/W 10%	

All tolerances are 20% unless otherwise stated.

COILS

No.	Ohms	Description	Code No.
L1	24.0-32.5	Aerial coil	CZ.323.019
L2	2.0-3.0		
L3	1.0-2.0	Oscillator coil	CZ.330.606
L4	3.5-5.0		
L5	11.5-15.5	1st I.F. transformer	A3.124.25
L6	11.5-15.5		
L7	11.5-15.5	2nd I.F. transformer	A3.124.25
L8	11.5-15.5		
L9	7,000 ohms	Output transformer	Type EBG96
L10			
L11		Speaker	Type 5C, F87
L12	55-75	Power transformer	CZ.344.084
L13	630-850		
L14	<0.5		

IMPORTANT! In ordering spare parts, quote **CODE NUMBER** of part and **MODEL NUMBER** of Receiver. In claiming free replacement under **GUARANTEE**, return defective part **PROMPTLY** and quote **MODEL** and **SERIAL NUMBER** of Receiver and **DATE OF PURCHASE**.