

# PHILIPS RADIOPLAYER

## MODEL 152

### SPECIFICATIONS

(Subject to alteration without notice)

Power Supply .....	220-260V, 40-60c/s.
Tuning Ranges .....	530-1620kc/s.
Intermediate Frequency .....	455kc/s.
Cabinet .....	Bakelite Table.

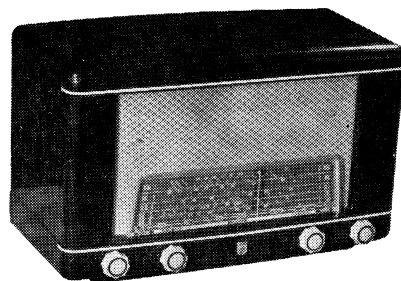

### VALVE EQUIPMENT AND VOLTAGE ANALYSIS

Valve Function	Valve No.	Valve Type	Plate Volts	Screen Volts	Osc. P. Volts
Frequency Converter	V1	6AN7	225	30	85
I.F. Amplifier Demodulator and A.V.C.	V2	6N8	225	50	—
Audio Amplifier	V3	6N8	75	14	—
Power Amplifier	V4	6M5	207	225	—
Rectifier	V5	EZ82	Cathode — L17 C.T., 262V.		
Dial Lamps	V11 & 12	6.3V. 0.32A. tubular screw			

Voltage across R23, -1.8V.; across R23 and 24, -6.4V.

NOTE: These voltages are measured with an "1,000 ohms per volt" meter and may vary  $\pm 10\%$  from the figures quoted. They are measured from the socket points quoted to chassis, or across the resistors listed. The receiver should be in a "no signal" condition.

#### MAINS VOLTAGE ADJUSTMENT.

The power transformer is provided with two mains voltage tappings—220/240 volts and 250/260 volts—for adjustment to the supply voltage at the point of installation. This receiver is adjusted at the factory to the 220/240 volts tapping.

#### DIAL CALIBRATION.

If it is required to correct dial calibration for an equal error on all stations, provision is made for moving the cursor assembly with respect to the dial cord. Loosen the clamping screw, make the necessary adjustment to the cursor position and securely retighten the clamping screw. This operation can be carried out without the need to remove the chassis from the cabinet.

#### TO REMOVE CHASSIS FROM CABINET.

Remove the power plug from the supply outlet socket. Remove the four control knobs (a firm pull is all that is necessary) and the cabinet back. The chassis is held to the cabinet by two screws in the baffle and four screws through the bottom of the cabinet. Removal of these six screws enables the chassis to be withdrawn from the cabinet.

The chassis may be replaced by a reversal of the above procedure.

#### ALIGNMENT.

The iron cores for the secondaries of the I.F. transformers are located in the top of the cans, those for the primaries are in the bottom of the cans. When trimming the I.F. circuits care should be taken not to screw the iron cores in too far otherwise undesired coupling may give rise to a false peak. A preliminary positioning to the outer edge of the former of all iron cores should

be made. Then, when trimming is being carried out, the cores should not be screwed in beyond the first peak. Metallic tools should not be used for I.F. transformer trimming.

Damped alignment of the I.F. channel is necessary. The procedure is:—

- Connect a 100 pF capacitor across the secondary of the 1st I.F.T.
- Trim in order, secondary of 2nd I.F.T., primary of 2nd I.F.T. and primary of 1st I.F.T.
- Check (b).
- Remove the shunt from the secondary of the 1st I.F.T. and trim this circuit.
- Check (d).
- Do not alter adjustments without 100 pF shunt in position.

Broadcast band alignment frequencies are 1,420 kc/s (oscillator and aerial trimmers), and 600 kc/s (slug padding). The alignment calibration scale is stencilled on the dial drum. An auxiliary pointer to use with this scale can be made up from workshop materials and fixed to a convenient point on the tuning capacitor mounting bracket. The various markings on the scale are (reading in an anti-clockwise direction):—

Stop mark (gang fully closed)  
 550 kc/s (large dot)  
 600 kc/s (large and small dots together)  
 then 100 kc/s steps to 1,300 kc/s  
 1,420 kc/s (large and small dots together)  
 1,500 kc/s

**Do not attempt to adjust the iron core of the aerial coil.**

Published by Philips Electrical Industries Pty. Limited

Sydney - Melbourne - Brisbane - Adelaide - Perth

PARTS LISTS

**CAPACITORS**

No.	Description	Code No.
C2-10	100 pF mica	
C3-25	0.05 mF 200V paper	
C5-13	30 pF air trimmer	CZ.113.700
C6-7	2 gang tuning	CZ.107.746
C8-18-28	0.01 mF 600V paper	
C11	475 pF mica 2%	CZ.066.119
C12	20 pF mica	
C16-17-22-23	Part of I.F. transformers	
C19-27	24 mF 350V electrolytic	
C20	100 pF ceramic 10%	
C21-29	30 pF mica	
C24	0.002 mF 600V paper	
C26-33	0.02 mF 400V paper	
C30	50 pF mica 10%	
C31	150 pF mica	
C32	10 mF 40V electrolytic	
C34	0.02 mF 600V paper	

All tolerances are 20% except where otherwise stated.

**RESISTORS**

No.	Description	Code No.
R1	50,000 ohms 1W carbon	
R2-6	150,000 ohms 1W carbon	
R3-10-14-19	50,000 ohms ½W carbon	
R5	30,000 ohms 1W carbon	
R7-8	2 megohms ½W carbon	
R9	0.5 megohms ½W carbon	
R11	5,000 ohms ½W carbon	
R12-22	100,000 ohms ½W carbon	
R13	0.5 megohm tapped carbon potentiometer	CZ.029.134
R15	10 megohms 1W carbon	
R16	1 megohm 1W carbon	
R17	250,000 ohms 1W carbon	
R18	1 megohm ½W carbon	
R20	25 ohms ½W carbon 10%	
R21	400 ohms ½W carbon	
R23	35 ohms 1W W/W 10%	
R24	100 ohms 1W W/W	

All tolerances are 20% except where otherwise stated.

**COILS**

No.	Ohms	Description	Code No.
L3	25.5-34.5	Aerial coil	CZ.323.007
L4	1.7- 2.3		
L7	2.9- 3.9	Oscillator coil	CZ.330.600
L8	1.0- 1.4		
L9	11.5-15.5	1st I.F. transformer	CZ.320.429
L10	11.5-15.5		
L11	11.5-15.5	2nd I.F. transformer	CZ.320.430
L12	11.5-15.5		
L13	440-590	Filter choke	CZ.341.000
L14	510-690	Speaker and transformer 6,000 ohms	CZ.161.111
L15	<0.5		
L16	2.5- 3.5		
L17	550-750	Power transformer	CZ.344.035
L18	<1.0		
L19	<0.5		
L20	47-63		

**IMPORTANT!** In ordering spare parts, quote CODE NUMBER of part and MODEL NUMBER of Receiver. In claiming free replacement under GUARANTEE, return defective part PROMPTLY and quote MODEL and SERIAL NUMBER of Receiver and DATE OF PURCHASE.

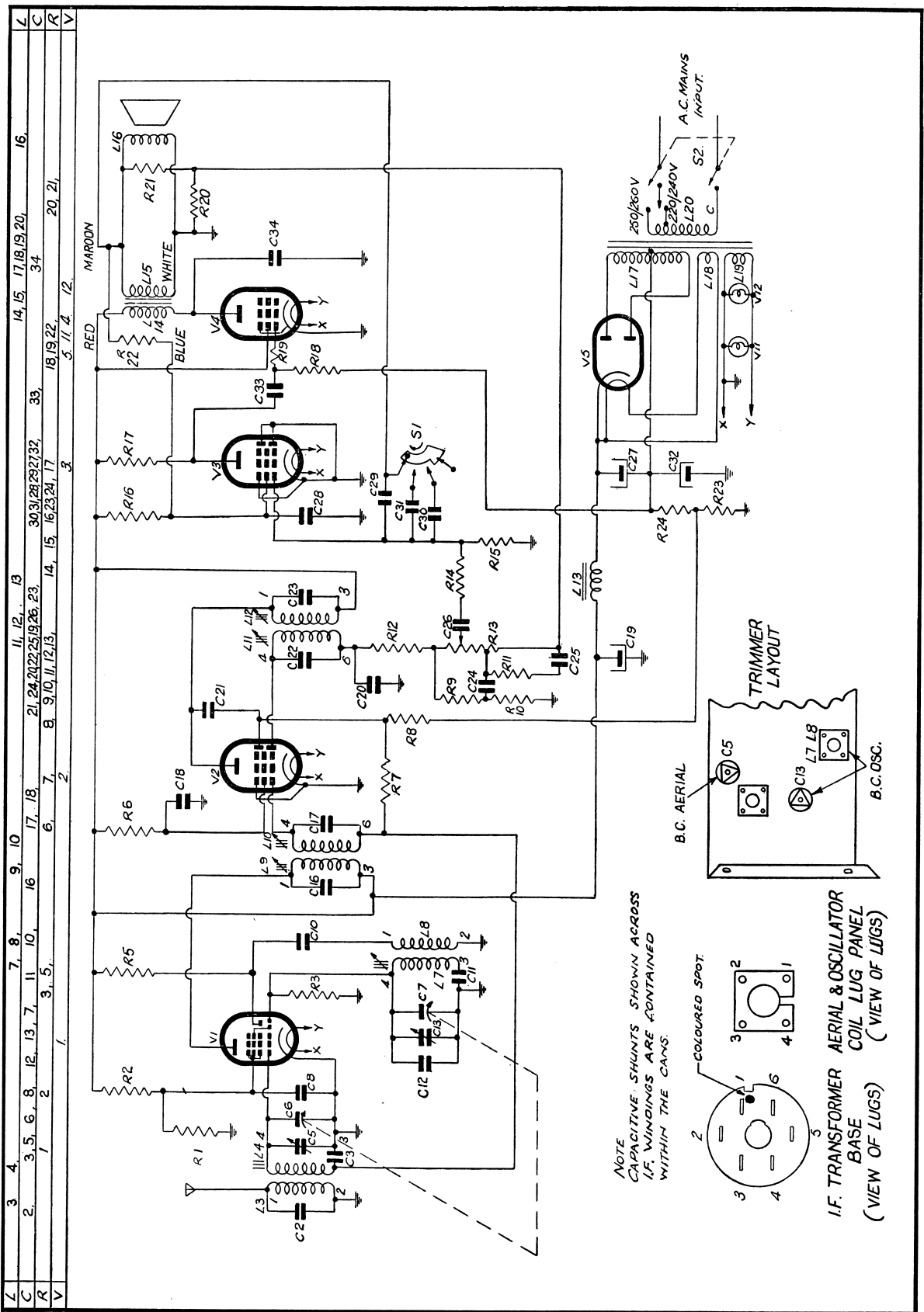

L	3	4	7	8	9	10	11	12	13	14	15	17	18	19	20	21	34	16																
C	2	3	5	6	8	12	13	7	11	10	16	17	18	21	24	22	25	19	26	23	30	31	28	29	32	33	18	19	22	5	11	4	12	
R	1	2	1	2	3	5	1	2	6	7	8	9	10	11	12	13	14	15	16	23	24	17	3	16	17	18	19	20	21	20	21			
V																																		

NOTE CAPACITIVE SHUNTS SHOWN ACROSS I.F. WINDINGS ARE CONTAINED WITHIN THE CAN.

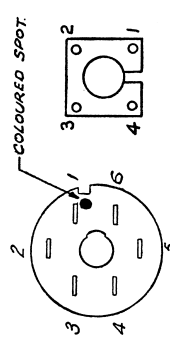

I.F. TRANSFORMER AERIAL & OSCILLATOR COIL LUG PANEL (VIEW OF LUGS)

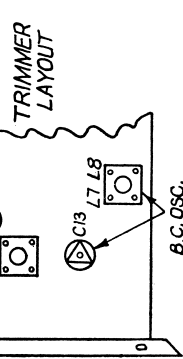

B.C. OSC.

## MISCELLANEOUS COMPONENTS

No. on Dial Cord			No. on Dial Cord		
Layout Drawing	Description	Code No.	Layout Drawing	Description	Code No.
—	Assembly, baffle	CR.005.236	—	Grommet, gang bracket, 3x	CS.422.458
—	Assembly, cursor	CR.480.639	—	Grommet, power cord	CS.422.457
—	Assembly, lampholder, 2x	CZ.367.900	—	Knob, control, 4x	CS.432.623
—	Assembly, pulley spindle, 2x	CR.436.206	—	Nipple, sl. rod. adj.	CS.274.603
—	Assembly, pulley spindle	CR.436.208	—	Plate, lampholder mtg.	CS.240.021
5	Assembly, tuning spindle	CR.371.320	3	Pulley, dial, 4x	CS.359.602
—	Back, cabinet	CS.462.089	—	Ring, C (tuning spindle)	CS.281.802
—	Badge, Philips	CS.436.416	6	Ring, dial cord	CS.281.807
—	Bracket, gang mtg.	CS.224.609	—	Rod, dial slide	CS.382.213
—	Bracket, cab. back mtg., 4x	CS.244.602	—	Scale, dial	CS.412.364
—	Cabinet	CS.460.505	—	Socket, valve (noval wafer), 5x	CZ.369.702
—	Clip, coil can mtg., 6x	CS.235.833	2	Spring, dial drum	CS.210.010
—	Clip, dial scale R.H.	CS.227.004	—	Strip, masking	CS.050.413
—	Clip, dial scale L.H.	CS.227.003	—	Switch, mains on/off	CZ.210.109
—	Cloth, baffle	CE.081.85	—	Switch, tone control	CZ.200.236
4	Cord, dial drive	CS.361.829	—	Washer, felt (knobs), 4x	CS.424.056
1	Drum, dial	CS.360.006			

### DIAL CORD LAYOUT

VIEW FROM REAR OF CHASSIS.

