

# KRIESLER AUSTRALASIA PTY. LIMITED

43 ALICE ST. NEWTOWN.

Phone: LA. 0400

Series 'A' Radio Handbook

MODEL 11-91

STEREOPHONIC RADIOGRAM

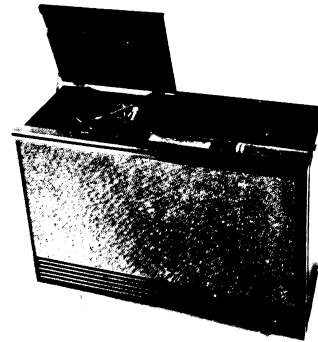

## DESCRIPTION.

Model 11-91 is a seven valve, Broadcast Band Radiogram designed for the reproduction of Monaural or Stereophonic records. The chassis is equipped with dual audio amplifiers, two 5" twin-cone high frequency "tweeters" and two 12" bass "Woofers". The record changer is a four speed automatic model with a "Turnover" ceramic pick-up cartridge. The stylus has two tips - a diamond tip for L.P. Monaural and Stereophonic records on one side - a sapphire tip for 78 RPM records on the other side.

RECORD CHANGER. Garrard Model AT6.

STYLUS (Dual). Garrard N8TSD. PICK-UP. Sonotone 8TA.  
Pressure 6 grams.

## OPERATING VOLTAGES

200 to 250 volts, 50 c.p.s. 240 volt primary tapped at 220 volts).

## AERIAL.

An inbuilt ferrite-rod aerial provides adequate signal reception for areas within a reasonable distance from radio stations. An external aerial connection is provided (red lead at rear of cabinet), for use in difficult reception areas.

## EARTH.

Since three-core power flex is used, no separate earth is required.

## TUNING RANGE.

525 to 1635 Kc/s.

## INTERMEDIATE FREQUENCY.

455 Kc/s.

## TO REMOVE CHASSIS AND RECORD CHANGER.

Refer card on rear of cabinet.

## REPLACEMENT PARTS - NON ELECTRICAL.

Control Panel Escutcheon ... 36-4124.

Transparent Dial Cover ..... 20-4096.

Knobs ...

Tuning ..... 20-4103.

Volume ..... 20-4104.

Balance ..... 20-4101.

Tone ..... 20-4102.

Dial Scale ..... 69-4129.

Dial Pointer ... 16-4086.

Push-Buttons ...

Black ..... 20-4098.

Red ..... 20-4099.

White ..... 20-4100.

## CHASSIS LAYOUT DIAGRAM

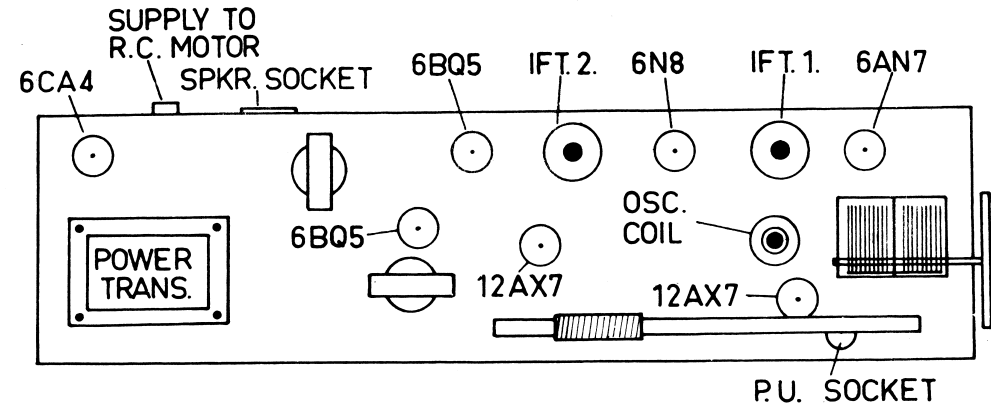

MODEL 11-91

EXTEND SPRING TO 1 1/2" FOR CORRECT CORD TENSION.

SPRING

START

START WITH 7 FEET OF CORD

3 1/2 TURNS

POINTER AT RIGHT-HAND END OF TRAVEL