

View from underside of Panel.

MATERIAL	Before production is commenced 2 samples must be submitted to Drawing Office for approval.							
FINISH	Work to Dimensions only.	DRAWN	R. L. K.	3/16/54	USED ON	USED ON	QTY.	QTY.
	TOLERANCES: Unless otherwise specified Tolerances to be read as:—	CODING						
	+ On Fractions. + on Decimals.	PLANNING						
SCALE	Prescription No.	CHECKED						
DIAL DRIVE LAYOUT		11-48-11-51.		ISSUE	1			
SHEET No.	This Drawing must be returned to			APPROVED		Card No.		
No. of Sheets.	KRIESLER (A'SIA) PTY. LTD.					File No.		
	43 ALICE ST., NEWTOWN, SYDNEY.							

To Remove Chassis:-

Remove three control knobs, two screws in back of cabinet, and four screws in base of cabinet. Remove loose back of cabinet, and chassis can be removed through rear of cabinet.

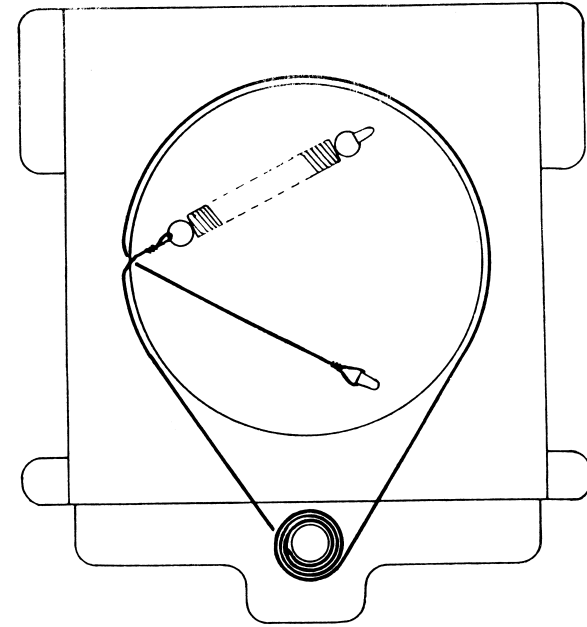

Viewed from rear of receiver with 'gang' in closed position.

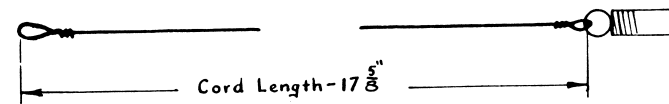

MATERIAL								
FINISH								
Before production is commenced 2 samples must be submitted to Drawing Office for approval.								
Work to Dimensions only.	DRAWN	L. T. B.	19-7-55	USED ON	QTY.	USED ON	QTY.	
TOLERANCES: Unless otherwise specified Tolerances to be read as:—	CODING			11-50	1.			
+ On Fractions. + on Decimals.	PLANNING							
SCALE	Prescription No.	CHECKED	R. L. K.	28-7-55				
DIAL CORD LAYOUT.					11-50.			
SHEET No.	This Drawing must be returned to			APPROVED		Card No.		
No. of Sheets.	KRIESLER (A'SIA) PTY. LTD.					File No.		
	43 ALICE ST., NEWTOWN, SYDNEY.							

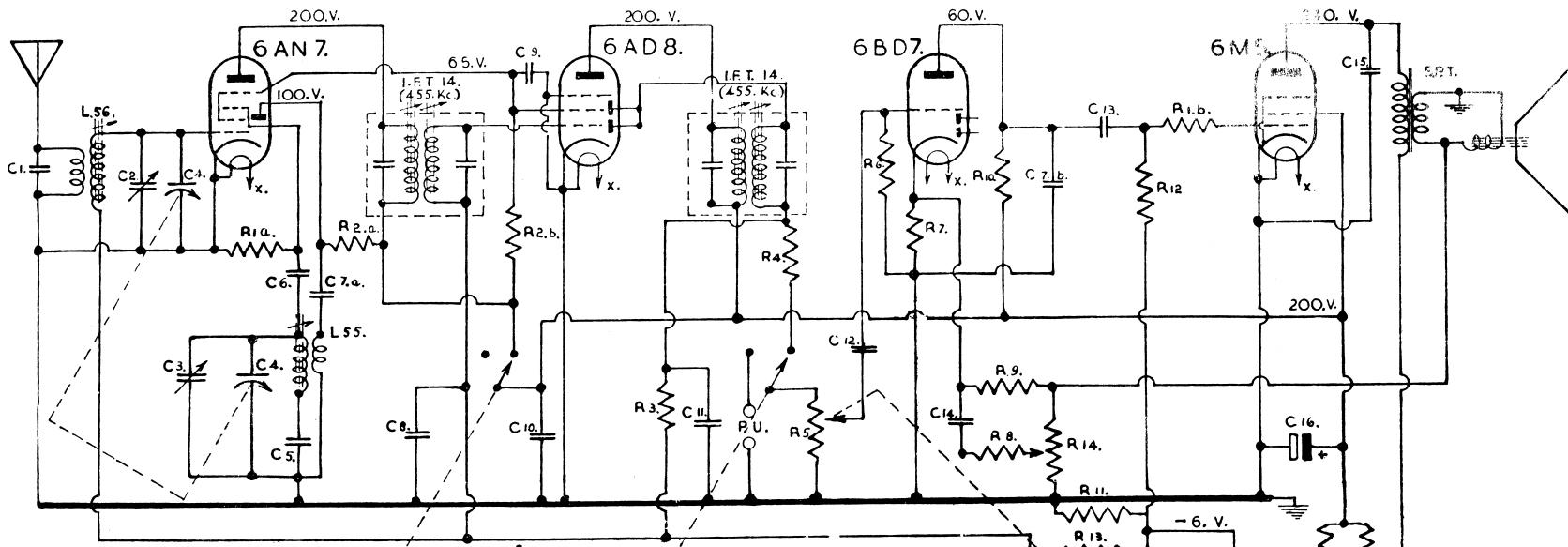

NOTE. ALL VOLTAGE MEASUREMENTS WERE TAKEN, WITH RESPECT TO EARTH, WITH A VOLTMETER 20,000 Ω/V. ON D.C. & 1,000 Ω/V. ON A.C. FREQUENCY COVERAGE - 535 Kc./s. - 1660 Kc./s.
 CORRECT PHASING OF SPEAKER TRANSFORMER SECONDARY IS ESSENTIAL.
 MAINS SWITCH IS ACTUATED BY POTENTIOMETER SPINDLE.
 WHEN ORDERING REPLACEMENT PARTS, PLEASE STATE THE FOLLOWING: RECEIVER, MODEL NO, CHASSIS NO, PART NO
 CIRCUIT DESIGNATION & GENERAL DESCRIPTION.

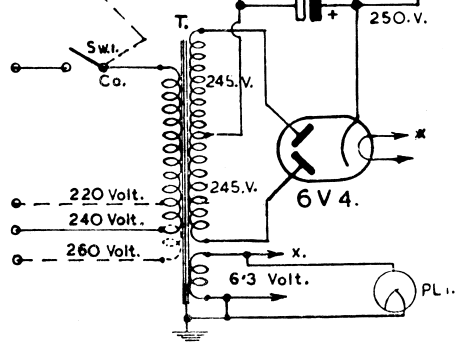

Circuit Designation	DESCRIPTION.	Part No	Circuit Designation	DESCRIPTION.	Part No
R.1.a.b.	Resistor Carbon 47 KΩ. ± W. ±10%		C.7.a.b.	Capacitor Mica 250. pf. ±15%	
R.2.a.b.	" " 27 KΩ. ± W. ±10%		C.8.	" Paper .05. μf. 200 Volt. ±15%	
R.3.	" " 1 MΩ. ± W. ±10%		C.9.	" " .03. μf. 400 " ±15%	
R.4.	" " 100 KΩ. ± W. ±10%		C.10.	" " .05. μf. 400 " ±15%	
R.5.Swt.	Potentiometer Switch 5 MΩ. I.W. S.P. ST.	32-22	C.11.	" Mica 150 pf. ±15%	
R.6.	Resistor Carbon 10MΩ. ± W. ±10%		C.12.	" " .002 μf. ±15%	
R.7.	" " 300Ω. ± W. ±10%		C.13.	" Paper .02 μf. 600 Volt.	
R.8.	" " 220Ω. ± W. ±10%		C.14.	" " .1 μf. 200 "	
R.9.	" " 15 KΩ. ± W. ±10%		C.15.	" " .005 μf. 600 "	
R.10.	" " 270KΩ. ± W. ±10%		C.16.	" Electrolytic 16 μf. 350 " ±40%	
R.11.	" " W.W. 125Ω. ± W. ±10%		C.17.	" " 30 μf. 350 " ±40%	
R.12.	" " Carbon .47 MΩ. ± W. ±10%				
R.13.	" " 4.7 MΩ. ± W. ±10%				
R.14.	Potentiometer 20 KΩ. I. W. ±20%				
R.15.a.b.	Resistor Carbon 6.8 KΩ. I. W. ±10%		L 55.	Coil B/C Oscillator.	40-22
			L 56.	" B/C Aerial.	40-23
			I.F.T.14.	I.F. Transformer 455 Kc/s. 2. off.	
C.1.	Capacitor Mica Simplex 100 pf. ±15%		T.	Power Transformer	18-88
C.2.	" Trimmer H.Y.Q. 5-50 pf.		S.W.2.	2 Pole 2 Position Switch	17-39
C.3.	" Wire Trimmer 0-30 pf.		S.P.T.	Speaker Transformer 7000Ω - 3.	
C.4.	" S/C 2 GANG.		SPEAKER	MAGNOVOX 12 P-2	
C.5.	" Mica 435 pf. ±2.5%		PL1	DIAL LIGHT 6.3 V. 3A. M.E.S. BASE.	
C.6.	" " 50 pf. ±15%				

MATERIAL	PLANNED	PROJECT	QTY.	PROJECT	QTY.	PROJECT	QTY.
GAUGE							
FINISH							
Prescription No.							

A. C. RECEIVER. 11-51.

Before production is commenced 2 samples must be submitted to Drawing Office for approval. This Drawing must be returned to KRIESLER AUSTRALASIA PTY. LTD., 43 ALICE STREET, NEWTOWN. SCALE

Procedure for Removal of Chassis and Record-Changer Unit from Cabinet

WARNING: Before attempting removal of chassis or motor unit from cabinet, or making any adjustments to this receiver, turn off at power point and remove plug.

MODEL No. 11-51 — 5 Valve Radiogram

VALVE TYPES 6AN7 : 6AD8 : 6BD7 : 6M5 : 6V4

● Removal of Chassis:

1. Open plastic shutter on radio side.
2. Remove two screws on edge of dial panel (see sketch) and slide panel towards end of cabinet.
3. Tilt panel by pressing on overhanging edge and lift panel and chassis out of cabinet.
4. Place piece of felt or similar material on centre section of cabinet and lay receiver on it.
5. Disconnect speaker, pick-up and motor leads by detaching clips and plug.
6. Chassis and wooden panel can now be lifted free of cabinet.

● Removal of Record-Changer Unit:

1. Open plastic shutter—record-changer unit side.
2. Remove five screws situated on edge of motor board (see sketch).
3. Lift outer end of motor board and pull unit towards end of cabinet about ¼" to clear slot.
4. Lift unit out, stand on its edge and disconnect pick-up and motor leads by detaching clips and plugs.
5. Record-changer unit and board can now be lifted free of cabinet.

● Removal of Plastic Shutters:

1. Remove two dome-headed stops at the bottom of shutter runner slots on each side of cabinet (see sketch).
2. Slide shutters out through bottom of cabinet.

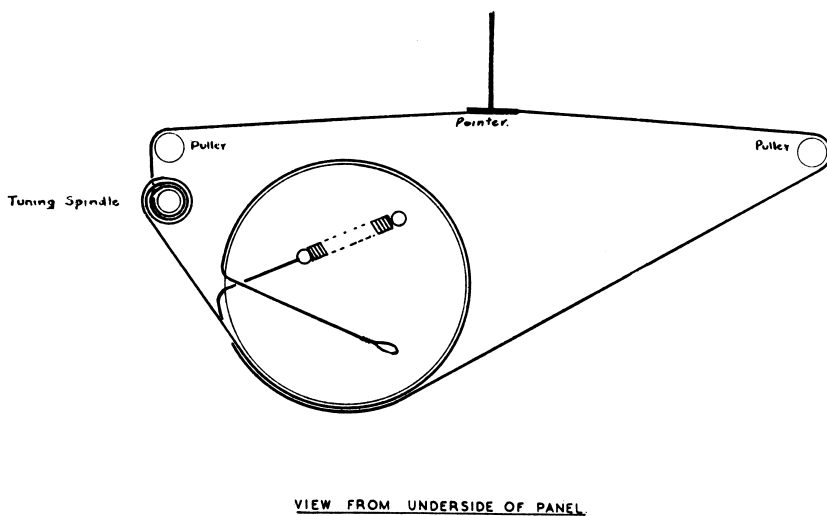
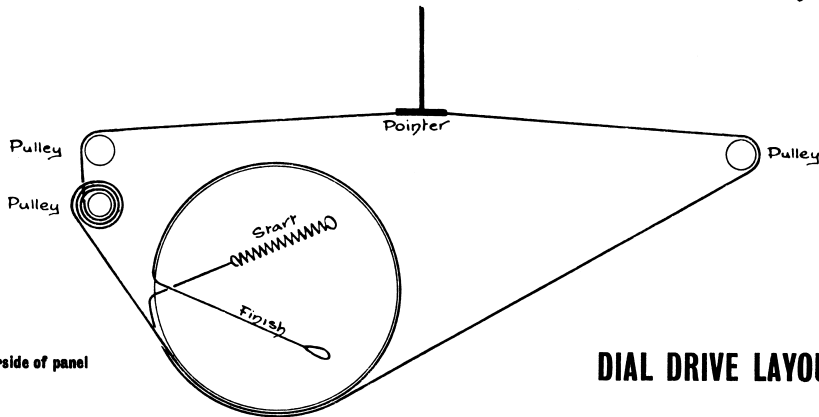
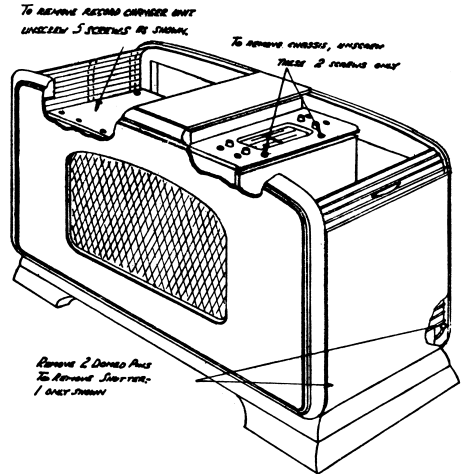

TO REMOVE CHASSIS:—

LAY CABINET ON RADIO SIDE END, SLIDE OUT BASEBOARD, FREEING POWER FLEX, AERIAL, & EARTH LEADS. REMOVE CONTROL KNOBS & UNSCREW FOUR CHROMIUM PLATED SCREWS ON TOP SECTION OF CABINET. CHASSIS CAN NOW BE REMOVED THROUGH BASE OF CABINET.

MATERIAL								
FINISH								
Before production is commenced 2 samples must be submitted to Drawing Office for approval.								
Work to Dimensions only. TOLERANCES: Unless otherwise specified Tolerances to be read as:—		DRAWN	L. T. B.	28-7-56	USED ON	QTY.	USED ON	QTY.
+ On Fractions. + on Decimals.		CODING						
		PLANNING						
SCALE	Prescription No.	CHECKED	R. L. K.	28-7-56				
DIAL DRIVE LAYOUT.					11-53.			
					ISSUE	1		
SHEET No.	This Drawing must be returned to				APPROVED			
No. of Sheets.	KRIESLER (A'SIA) PTY. LTD.							
	43 ALICE ST., NEWTOWN, SYDNEY.							

K9 & 10.