

TECHNICAL BULLETIN

**CALIBRATION PROCEDURE
FOR
OSCILLOSCOPE, HEWLETT-PACKARD
MODELS 175A, HO-175A, AND H12-175A
(AN/USM-186 AND OS-157/U)
(AN/USM-215 AND OS-170/USM-215)
VERTICAL AMPLIFIER
MODELS 1750A, 1750B, (AM-4031A/U) 1752A, AND 1754A; AND
DELAY GENERATOR MODELS 1781A AND 1781B;
SWEEP GENERATOR SG-988/U**

**This copy is a reprint which includes current
pages from Change 1**

DEPARTMENT OF THE ARMY TECHNICAL BULLETIN

CALIBRATION PROCEDURE
FOR
OSCILLOSCOPE, HEWLETT-PACKARD MODELS 175A,
HO-175A, AND
H12-175A (AN/USM-186 AND OS-157/U)
(AN/USM-215 AND OS-170/USM-215)
VERTICAL AMPLIFIER
MODELS 1750A, 1750B, (AM-4031A/U) 1752A, AND 1754A;
AND DELAY GENERATOR MODELS 1781A
AND 1781B; AND
SWEEP GENERATOR SG-988/U

Headquarters, Department of the Army, Washington, DC
30 September 1976

TB 11-6625-266035, 7 November 1975, is changed as follows:

Page 3. Paragraph 2, line 8. "AMSEL-MA-Q" is changed to read "DRSEL-MA-Q."

Page 25. Table 14, *Max* column, first listing. "9.515V pp" is changed to read "0.515V pp."

By Order of the Secretary of the Army:

Official:

FRED C. WEYAND
General, United States Army
Chief of Staff

PAUL T. SMITH
Major General, United States Army
The Adjutant General

DISTRIBUTION:

To be distributed in accordance with DA Form 12-34A literature requirements for calibration procedures publications.

TECHNICAL BULLETIN }
 No. 11-6625-2660-35 }

HEADQUARTERS
 DEPARTMENT OF THE ARMY
 WASHINGTON, DC, 7 November 1975

**CALIBRATION PROCEDURE
 FOR
 OSCILLOSCOPE, HEWLETT-PACKARD MODELS 175A, HO-175A, AND
 H12-175A (AN/USM-186 AND OS-157/U)
 (AN/USM-215 AND OS-170/USM-215)
 VERTICAL AMPLIFIER
 MODELS 1750A, 1750B, (AM-4031A/U) 1752A, AND 1754A; AND DELAY
 GENERATOR MODELS 1781A AND 1781B;
 SWEEP GENERATOR SG-988/U**

SECTION		Paragraph	Page
I.	INTRODUCTION AND DESCRIPTION		
	Purpose and scope-----	1	3
	Reporting of technical bulletin improvements-----	2	3
	Descriptive data-----	3	3
	General instructions-----	4	4
	Differences among models-----	5	4
II.	CALIBRATION PROCEDURE FOR OSCILLOSCOPE MODELS 175A, HO-175A and H12-175A (AN/USM-186 AND OS-157/U) (AN/USM-215 and OS-170/USM-215).		
	Equipment and accessories required-----	6	5
	Preliminary procedure-----	7	6
	Display pattern-----	8	6
	Sweep gain-----	9	7
	Horizontal balance-----	10	7
	Horizontal amplifier gain-----	11	8
	Horizontal compensation-----	12	9
	Trigger sensitivity-----	13	9
	Sweep time-----	14	10
	Vertical amplifier gain-----	15	11
	Scan response-----	16	11
	Vertical pulse response-----	17	11
	Calibrator accuracy-----	18	12
	Power supplies-----	19	13
III.	CALIBRATION PROCEDURE FOR VERTICAL AMPLIFIER, MODEL 1750A		
	Preliminary procedure-----	20	14
	Gain and sensitivity-----	21	14
	Amplifier input capacitance-----	22	15
	Attenuator compensation-----	23	15
	Attenuator input capacitance-----	24	16
	Pulse response-----	25	16
IV.	CALIBRATION PROCEDURE FOR VERTICAL AMPLIFIER, MODEL 1750B (AM- 4031A/U).		
	Preliminary procedure-----	26	17
	Gain and sensitivity-----	27	17
	Attenuator compensation-----	28	18
	Attenuator input capacitance-----	29	18
	Pulse response-----	30	18
	B trigger output sensitivity and dc level-----	31	19
V.	CALIBRATION PROCEDURE FOR VERTICAL AMPLIFIER, MODEL 1752A		
	Preliminary procedure-----	32	21
	Gain and sensitivity-----	33	21
	Attenuator compensation-----	34	21
	Attenuator input capacitance-----	35	22
	Pulse response-----	36	23

*This bulletin supersedes TB 9-6625-998-50, 7 January 1971.

	Paragraph	Page
VI.	CALIBRATION PROCEDURE FOR VERTICAL AMPLIFIER, MODEL 1754A	
	Preliminary procedure -----	37 24
	Gain and sensitivity -----	38 24
	Attenuator compensation -----	39 25
	Attenuator input capacitance -----	40 25
	Pulse response -----	41 25
VII.	CALIBRATION PROCEDURE FOR DELAY GENERATOR, MODEL 1781A	
	Preliminary procedure -----	42 27
	Trigger symmetry -----	43 27
	Preset-----	44 28
	Sweep length -----	45 28
	Sweep calibration -----	46 28
	High-frequency compensation -----	47 28
	Delay length and sweep -----	48 29
VIII.	CALIBRATION PROCEDURE FOR DELAY GENERATOR, MODEL 1781B (SG-988/U)	
	Preliminary procedure -----	49 30
	Preset-----	50 30
	Trigger sensitivity and symmetry -----	51 30
	Sweep length -----	52 31
	Sweep calibration -----	53 31
	Delay length and sweep -----	54 32
IX.	MAINTENANCE CALIBRATION PROCEDURE FOR OSCILLOSCOPE H12-175A AND HO-175A	
	Equipment and accessories required -----	55 34
	Preliminary procedure -----	56 35
	Horizontal amplifier gain -----	57 35
	Sweep generator -----	58 37
	Vertical amplifier gain -----	59 39
	Vertical amplifier bandwidth -----	60 39
	Calibrator -----	61 40
	Intensity modulation -----	62 40
	Final procedure -----	63 41

SECTION I INTRODUCTION AND DESCRIPTION

1. Purpose and Scope. This bulletin provides information for the periodic calibration of Oscilloscope, Hewlett-Packard Models 175A and H12-175A (AN/USM-186 and OS-157/U); Vertical Amplifier Models 1750A, 1750B, 1752A and 1754A; and Delay Generator Models 1781A and 1781B. It is to be used by personnel trained and qualified in the use of calibration equipment.

2. Reporting of Technical Bulletin Improvements.

The reporting of errors, omissions, and recommendations for improving this bulletin is authorized and encourages. Reports should be submitted on DA Form 2028 (Recommended Changes to Publications and Blank Forms) and forwarded direct to Commander, US Army Electronics Command, ATTN: AMSEL-MA-Q, Fort Monmouth, NJ 07003.

3. Descriptive Data. a. Identification

(1) Oscilloscope:

Nomenclature -----OSCILLOSCOPE
Military designation -----AN/USM-186 and OS-157/U
Manufacturer -----Hewlett-Packard Co.
Model numbers -----175A and H12-175A
Reference -----Manufacturer's instruction manual.

(2) Vertical amplifier:

Nomenclature -----VERTICAL AMPLIFIER
Manufacturer -----Hewlett-Packard Co.
Model numbers -----1750A, 1750B, 1752A, and 1754A.
Reference -----Manufacturer's instruction manual.

(3) Delay generator:

Nomenclature -----DELAY GENERATOR
Manufacturer -----Hewlett-Packard Co.
Model numbers -----1781A and 1781B
Reference -----Manufacturer's instruction manual.

b. Specifications

(1) Oscilloscope:

Power requirements -----115 or 230 vac, $\pm 10\%$, 50 to 60 Hz, approx 425 w.
Internal sweep -----24 ranges, 0.1 $\mu\text{sec/cm}$ to 5 sec/cm, $\pm 3\%$. Continuous vernier adjustment to 12.5 sec/cm.
Sweep magnification -----X10, $\pm 5\%$
Triggering:
Internal -----Vertical input signal (from 2 mm at 1 MHz or below to approx 2 cm at 50 MHz).

External -----0.5 v pp or more, direct or capacitive coupling.

Triggering point:

Internal -----Any level of positive or negative going signal displayed on graticule.
External -----Any level of positive or negative going signal between -5 and +5v.

Horizontal band-

width -----Dc to 500 kHz

Horizontal sensi-

tivity -----2 ranges, 0.1 v/cm and 1 v/cm. Continuous vernier adjustment to 10 v/cm.

Horizontal input

impedance* -----1 megohm shunted by 30 pf

Vertical bandwidth ---Dc to greater than 50 MHz (less than 7 nsec rise time).

Internal calibrator:

Signal -----Approx 1 kHz square wave
Voltage -----2 ranges, 1 v and 10 v pp. $\pm 1\%$.

(2) Vertical amplifier, Models 1750A and 1754A:**

Sensitivity each channel:

Range -----0.05 to 20 v/cm in nine calibrated ranges. Vernier extends range to 50 v/cm and provides continuous control between ranges.

Accuracy ----- $\pm 3\%$

Band pass -----Dc coupled, dc to 40 MHz; ac coupled, 2 Hz to 40 MHz.

Rise time -----9 nsec or less

(3) Vertical amplifier, Model 1750B:

Sensitivity each channel:

Range -----0.05 to 20 v/cm in nine calibrated ranges. Vernier extends range to 50 v/cm and provides continuous control between ranges.

Accuracy ----- $\pm 3\%$

Band pass - Dc to at least 50 MHz

Rise time -----8 nsec or less

B trigger output -----Will trigger Model 175A oscilloscope sweep with approx 0.5-cm on crt when connected to Model 175A external trigger input.

- (4) Vertical amplifier,
1752A:
Sensitivity each
channel:
Range -----5 mv/cm to 20 v/cm in 12 cali-
brated ranges. Vernier
extends range to 50 v/cm
and provides continuous
control between ranges.
Accuracy-----±3%
Band pass:
Dc coupled-----Dc to 22 MHz at 50 mv/cm
and above, dc to 18 MHz at
20 mv/cm to 5 mv/cm.
Ac coupled -----Same as above except lower
frequency limit is 2 Hz.
- (5) Delay generator,
Models 1781A and
1781B:
Power input
requirements -----Supplied by oscilloscope,
Model 175A.
Delay sweep-----2 µsec/cm to 1 sec/cm; 18 cali-
brated ranges in a 1, 2, 5,
10 sequence.
Delay length -----(The physical location, in cm
from the beginning of the
trace, to the point at which
the main sweep is trig-
gered) : 0 to 10 cm.
Delay time
(Model 1781A)-----1 µsec to 10 sec
Delay time
(Model 1781B)-----0.5 µsec to 10 see
Delay accuracy-----±1%, 2 µsec to 0.1 sec/cm
ranges; ±3%, 0.2, 0.5 and
1 sec/cm ranges; ±0.2%
linearity.
Triggering-----Internal; power line or ver-
tical input signal (2 mm or
more vertical deflection).
External; ½ vpp or more.
Triggering point
(Model 1781A)-----Adjustable -30 to +30 volts
Triggering point
(Model 1781B)-----Adjustable -5 to +5 volts.

- c. *Calibration*
Time required -----6 hours (approx) for each unit.
Technique -----Dc - low frequency.
Interval -----In accordance with TB 43-180.

4. General Instructions. a. *Calibration Reporting.*

(1) Forms, records, and reports required for calibration personnel at all levels are prescribed by TM 38-750. DA Form 2416 (Calibration Data) must be annotated in accordance with TM 38-750 for each calibration performed.

(2) Adjustments to be reported on DA Form 2416 are designated (R) at the end of the sentence in which they appear. When the adjustments are in tables, the (R) will follow the designated adjustment. Report only those adjustments made and designated with (R).

b. *Test Instrument.* Oscilloscope, Hewlett-Packard Models 175A and H12-175A, (AN/USM-186 and OS-157/U); Vertical Amplifier, Models 1750A, 1750B, 1752A and 1754A; and Delay Generator, Models 1781A and 1781B, will be referred to as the TI (test instrument) throughout this bulletin.

c. *Equipment and Accessory Identification.* The equipment and accessories referred to throughout this bulletin are identified in tables 1 and 2.

d. *Equipment Setup.* Disconnect instructions are not contained in this bulletin.

e. *Power Supply for TI (Oscilloscope).* When indications specified in paragraphs 8 through 18 are not within tolerance, perform the power supply checks prior to making adjustments. After power supply adjustments are made, repeat paragraphs 8 through 18. Do not perform the power supply checks if all other parameters are within tolerance.

5. Differences Among Models Adjustment locations and front panels controls vary among models. These are indicated where applicable throughout the bulletin.

*This specification is for information only and is not necessarily verified in this bulletin.

**Model 1750A is a two-channel amplifier and 1754A is four-channel.

**SECTION II
CALIBRATION PROCEDURE FOR
OSCILLOSCOPE MODELS 175A, HO-175A AND H12-175A
(AN/USM-186 AND OS-157/U) (AN/USM-215
AND OS-170/USM-215)**

6. Equipment and Accessories Required. *a.*

Equipment required for calibration performance tests is listed in table 1, and is referenced within the text by common name and item identification number prefixed A.

b. Accessories required for calibration performance tests are listed in table 2 and are referenced within the text by common name and item identification number prefixed B.

NOTE

Minimum use specifications are the principal parameters required for performance of the calibration, and are included to assist in the selection of alternate equipment, which may be used at the discretion of the calibrating activity. Satisfactory performance of alternate items shall be verified prior to use. All applicable equipment must bear evidence of current calibration.

Table 1. Equipment Required for Secondary Transfer Calibration

<i>Item No</i>	<i>Common name</i>	<i>Minimum use specifications</i>	<i>Calibration equipment' (Identifying number)</i>
A1	Voltage calibrator.....	Range: 0.3499 to 3.712 V rms and 0.95 to 1.05 V pp Accuracy: ±1%	Ballantine, model 420 (8205523)
A2	Signal generator	Range: 50 MHz..... Accuracy: ±%	H-P model 608-CR (8598927-1)
A3	Square-wave generator	Range: 4 kHz to 1 MHz Rise time: Less than 7 nsec	TEK type 106 (MIS-10284)
A4	Marker generator	Range: 10 nsec to 5 sec..... Accuracy: ±1%	TEK type 184 (7912042-2)
A5	Test oscillator	Range: 0.03 to 0.05 V at 1 MHz Accuracy: ±1%	Preston model 134A (MIS-10224) or H-P, model 652A
A6	Oscilloscope.....	Range: 50 kHz to 1 MHz Accuracy: ±1%	TEK RM561A (7910655-2) W/type 3A6 (7911441-1) and 3B4 (7912040-1) plug-ins
A7	Horizontal plug-in**	Must be compatible with TI.....	H-P model 1750B 1780A, 1781A/B, 1782B or 1783B
A8	Vertical plug-in**	Must be compatible with TI.....	H-P model 1750B
A9	Ac voltage calibrator.....	Range: 1.7675 to 17.675 Vac at 1 kHz	H-P, model 745A
A10	Auto-transformer.....	Range: 105 to 125 Vac..... Accuracy: ±1%	G-R model W10MT3A (7910809)
A11	HV voltmeter.....	Range: -2600 to -2800 Vdc..... Accuracy: ±1.2%	Sensitive Research model DCHI VOLTH (8616326)
A12	Ac/dc voltmeter.....	Range: -103 to +380 Vdc..... Accuracy: ±0.9% dc	Dana, model 5703-5-2127 (7912606)

*The calibration equipment utilized in this procedure was selected from those issued with secondary transfer calibration standards set and the listing by make or model number carries no implication of preference, recommendation, or approval by the Department of Defense for use by other agencies. It is recognized that

equivalent equipment produced by other manufacturers may be capable of equally satisfactory performance in the procedure.

**Additional equipment required and must be calibrated and compatible with TI.

Table 2. Accessories Required for Secondary Transfer Calibration

Item number	Common name	Description
B1	Adapter	BNC jack-to-N plug.
B2	Adapter (2 required)	Single banana jack-to-alligator clip (black).
B3	Adapter	BNC T type, two jacks, one plug.
B4	Test adapter	Vertical and horizontal test fixture.
B5	Adapter box	Spade lug terminals-to-double banana jack.
B6	Cable (2 required)	30-in., RG-58() /U; BNC plug terminations.
B7	Cable	36-in., RG-58() /U; BNC plug and double banana plug terminations.
B8	Cable (2 required)	36-in., RG-58/U; BNC plug and alligator clips.
B9	Lead	24-in., No. 18 AWG single banana plug terminations (black).
B10	Test probe	10:1 voltage divider with BNC plug.
B11	Plug-in extender	H-P, model 10400B, 30-inch extension cable.
B12	Termination	50-ohm feed-through, BNC plug-to-BNC jack.

7. Preliminary Procedure.

NOTE
Personnel should familiarize themselves with the entire bulletin prior to performing calibration.

- a. Remove top and bottom covers from TI.
- b. Install horizontal plug-in (A7) TI.
- c. Install test adapter (B4) in TI vertical plug-in slot, using connector P1 of test adapter.
- d. Connect TI to autotransformer (A10).
- e. Connect autotransformer to 115-volt ac source and adjust for 115 volts ac.
- f. Position TI controls as listed in (1) through (9) below:
 - (1) HORIZONTAL DISPLAY switch to INT SWEEP MAGNIFIER X1.
 - (2) EXTERNAL VERNIER control to CAL.
 - (3) TRIGGER SOURCE switch to INT.
 - (4) TRIGGER SLOPE switch to + (positive).
 - (5) TRIGGER LEVEL control to 0 (zero).
 - (6) SWEEP MODE control to FREE RUN.
 - (7) SWEEP TIME switch to 1 mSEC/CM.
 - (8) SWEEP TIME' VERNIER control to CAL.
 - (9) INTENSITY MODULATION switch to INT (rear panel).
- g. Set horizontal plug-in SWEEP OCCURRENCE switch to NORMAL
- h. Set TI POWER switch to ON. Allow 30 minutes for TI to warmup and stabilize.
- i. Press BEAM FINDER switch and center trace on TI graticule with TI HORIZONTAL POSITION and test adapter BAL controls. Release BEAM FINDER switch.
- j. Adjust TI INTENSITY controls for normal intensity.
- k. Adjust FOCUS and R340 (Fig. 1) (for TI with serial numbers prefixed 235, or FOCUS and ASTIGMATISM for models prefixed with 344) to obtain sharply focused trace.

WARNING
HIGH VOLTAGE is used during the performance of this procedure.

DEATH ON CONTACT may result if personnel fail to observe safety precautions.

NOTE
When the TI is not within tolerance, perform the specified adjustment and continue the performance check. When the TI is not within tolerance and no adjustment is specified, the deficiency must be corrected before continuing with the procedure.

8. Display Pattern. a. Performance Check.

- (1) Set Power switch to Off and remove test adapter (B4) from TI. Install vertical plug-in (A8) and set POWER switch to ON.
- (2) Position vertical plug-in controls as listed in (a) through (e) below:
 - (a) Channel selector switch to CHANNEL A.
 - (b) Channel A AC-DC switch to AC.
 - (c) Channel A SENSITIVITY switch to .5 VOLTS/CM.
 - (d) Channel A SENSITIVITY VERNIER control to CALIBRATED.
 - (e) Channel A POLARITY switch to +UP.
- (3) Connect marker generator (A4) to vertical plug-in unit CHANNEL A INPUT connector, using cable (B6).
- (4) Adjust marker generator output to .1 gsec markers.
- (5) Adjust vertical plug-in SENSITIVITY and VERNIER controls and VERTICAL POSITION control for a 6-cm display coinciding with top and bottom lines of TI graticule.
- (6) Adjust TI HORIZONTAL POSITION control to align left side of display with left graticule edge. Observe that top, bottom, and left side of display coincides geometrically with graticule lines. If not, perform b(1) below.

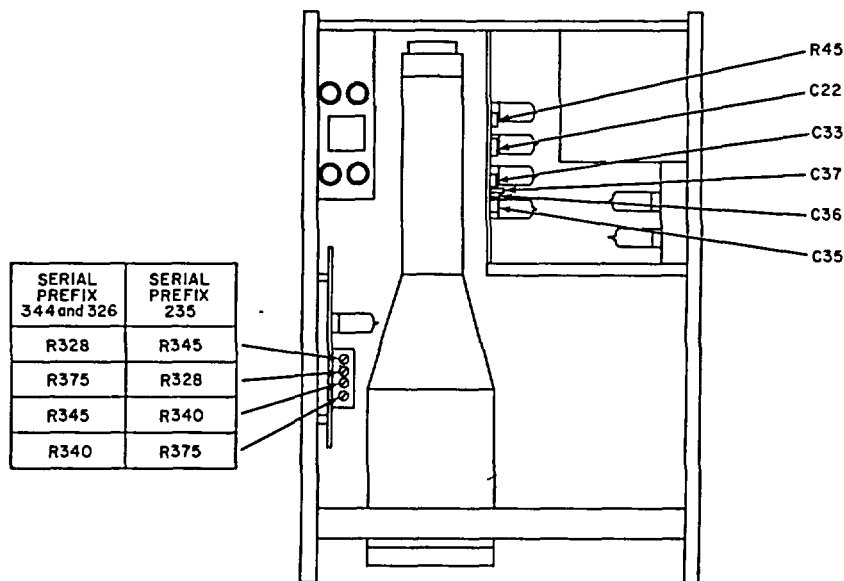

EL 6625-2660-35-TB-1

Figure 1. Oscilloscope, top interior view.

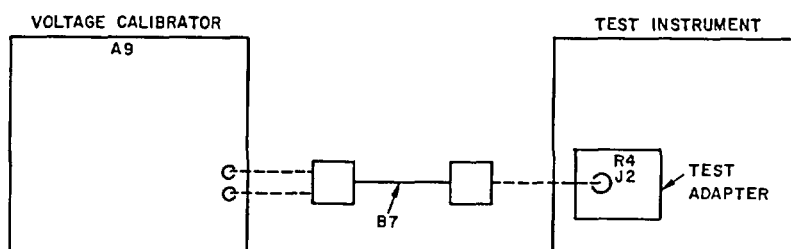

EL 6625 - 2660 - 35 - TB - 2

Figure 2. Oscilloscope sweep gain, equipment setup.

(7) Adjust TI HORIZONTAL POSITION control to align right side of display with right graticule edge. Observe that top, bottom, and right side of display coincides geometrically with graticule lines. If not, perform *b*(1) through (4) below.

b. Adjustments.

- (1) Adjust R345 (Fig. 1) for optimum coincidence of display with graticule lines.
- (2) Repeat a(6), and (1) above.
- (3) Repeat a(7), and (1) above.
- (4) Repeat (1) through (3) above until no further adjustment is required.

9. Sweep Gain. a. Performance Check.

- (1) Set autotransformer (A10) and TI POWER switches to OFF.
- (2) Remove horizontal plug-in (A7) from TI and install test adapter (B4). Remove two screws holding J2 and swing out slightly to accommodate test adapter (B4).
- (3) Connect equipment as shown in figure 2.
- (4) Set autotransformer and TI power switches to ON.

(5) Adjust ac voltage calibrator (A9) frequency to 1000 Hz.

(6) Adjust ac voltage calibrator amplitude for 17.675 volts rms. TI horizontal deflection will be 5.5 cm. If not, perform *b*(1) below.

(7) Adjust ac voltage calibrator amplitude for 1.7675 volts rms.

(8) Turn TI HORIZONTAL DISPLAY switch to INT SWEEP X10. TI horizontal deflection will be 5.5 cm. If not, perform *b*(2) below.

b. Adjustments.

(1) Adjust R225 (Fig. 3) until TI horizontal deflection is 5.5 cm. (R)

(2) Adjust R227 (Fig. 3) until TI horizontal deflection is 5.5 cm. (R)

10. Horizontal Balance. a. Performance Check.

(1) Turn TI SWEEP MODE control until it is just out of PRESET position.

(2) Adjust HORIZONTAL POSITION control until spot is horizontally centered on graticule.

NOTE

Depress BEAM FINDER if required.

(3) Turn HORIZONTAL DISPLAY switch to INT SWEEP X1. Observe that spot remains centered. If not, perform b(1) through (4) below.

(4) Turn HORIZONTAL DISPLAY switch to EXT. INPUT 0.1 VOLTS/CM DC.

(5) Turn EXTERNAL VERNIER control fully counterclockwise.

(6) Repeat (2) above.

(7) Turn EXTERNAL VERNIER control to CAL position. Observe that spot remains centered. If not, perform b(5) through (7) below.

(8) Turn TI SWEEP MODE control to PRESET.

b. Adjustments.

(1) Adjust R230 (Fig. 3) until spot is centered on graticule.

(2) Set HORIZONTAL DISPLAY switch to INT SWEEP X10.

(3) Repeat a(2) and (3) above.

(4) Repeat (1) through (3) above until no further adjustments are required.

(5) Adjust R212 (Fig. 3) until spot is centered on graticule.

(6) Repeat a(5) through (7) above.

(7) Repeat (5) and (6) above until no further adjustments are required.

11. Horizontal Amplifier Gain. a. Performance Check.

(1) Connect voltage calibrator (AI) output terminals to TI HORIZ INPUT connector, using cable (B7).

(2) Turn TI EXTERNAL VERNIER control to CAL.

(3) Adjust voltage calibrator output until TI horizontal deflection is 10 cm. Adjust HORIZONTAL POSITION control as required. Voltage calibrator will indicate between 0.95 and 1.05 volts pp. If not, perform b(1) and (2) below.

(4) Turn TI HORIZONTAL DISPLAY switch to EXT. INPUT .1VOLT/CM AC.

(5) Adjust voltage calibrator output until TI horizontal deflection is 10 cm. Adjust HORIZONTAL POSITION control as required. Voltage calibrator will indicate between 0.95 and 1.05 volts pp.

(6) Turn TI HORIZONTAL DISPLAY switch to EXT. INPUT 1 VOLTS/CM DC.

(7) Adjust voltage calibrator output until TI horizontal deflection is 10 cm. Voltage calibrator will indicate between 3.358 and 3.712 volts rms.

(8) Turn TI HORIZONTAL DISPLAY switch to EXT. INPUT 1 VOLT/CM AC.

(9) Repeat (7) above.

b. Adjustments.

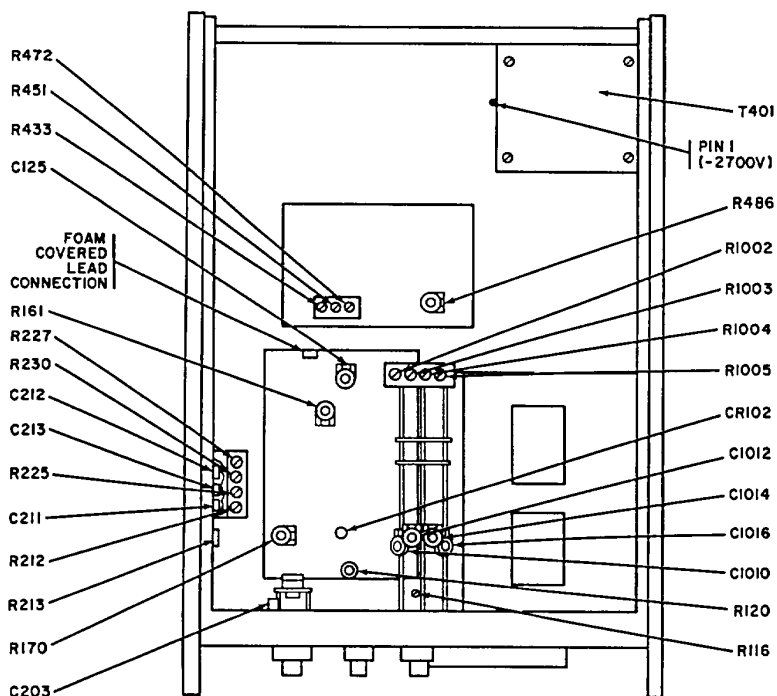

EL 6625-2660-35-TB-3

Figure 3. Oscilloscope, bottom interior view.

- (1) Adjust voltage calibrator to 1.0 volt pp.
- (2) Adjust R213 (Fig. 3) until TI horizontal deflection indicates 10 cm. (R)

12. Horizontal Compensation a. Performance Check.

(1) Connect square-wave generator (A3) HI AMPLITUDE OUTPUT connector to test adapter (B4) J2 connector, using cable and termination supplied with square-wave generator.

(2) Connect square-wave generator TRIGGER OUTPUT to TI TRIG. INPUT, using cable (B6).

(3) Connect vertical plug-in (A8) input jack to FOAM COVERED LEAD CONNECTION on sweep generator circuit board (Fig. 3), using cable (B8).

(4) Turn vertical plug-in SENSITIVITY switch to 10 VOLTS/CM and VERNIER control to CALIBRATED.

(5) Position TI controls as listed in (a) through (c) below:

(a) HORIZONTAL DISPLAY switch to INT SWEEP MAGNIFIER X1.

(b) TRIGGER SOURCE switch to EXT. AC.

(c) SWEEP TIME switch to .1 mSEC/CM.

(6) Adjust square-wave generator frequency to 4 kHz and amplitude output to maximum. Square waves displayed will have flat tops (disregard spikes). If not, perform b(1) below.

(7) Turn TI HORIZONTAL DISPLAY switch to X10 and adjust square-wave generator amplitude for 8-cm deflection on TI.

(8) Repeat (6) above. Square waves displayed will have flat tops (disregard spikes). If not, perform b(1) and (2) below.

(9) Adjust square-wave generator frequency to 40 kHz.

(10) Turn HORIZONTAL DISPLAY switch to X1 and SWEEP TIME switch to 10 μ sec/cm.

(11) Adjust square-wave generator amplitude output to maximum. Square waves displayed will have flat tops (disregard spikes). If not, perform b(3) below.

(12) Repeat (7) above. Square waves displayed will have flat tops (disregard spikes). If not, perform b(4) below.

(13) Turn TI HORIZONTAL DISPLAY switch to EXT. INPUT 1 VOLTS/CM DC.

(14) Disconnect cable connected in (3) above.

(15) Connect square-wave generator HI AMPLITUDE OUTPUT connector to TI HORIZ INPUT connector, using cable and termination supplied with square-wave generator.

(16) Adjust square-wave generator frequency to 4 kHz and amplitude for 8-cm deflection on TI. Dots

displayed on TI will be round with no tails. If dots displayed on TI are not round, perform b(5) below.

b. Adjustments.

(1) Adjust C211 (Fig. 3) for flat tops. (R)

(2) Repeat a(5) and (6) above. (R)

(3) Adjust C213 (Fig. 3) for flat tops. (R)

(4) Adjust C212 (Fig. 3) for best square wave.

(R)

(5) Adjust C203 (Fig. 3) until dots displayed on TI are round and show no indication of "tails." (R)

13. Trigger Sensitivity a. Performance Check.

(1) Remove test adapter (B4) from TI horizontal circuit and install horizontal plug-in (A7) in TI.

(2) Set horizontal plug-in SWEEP OCCURRENCE switch to NORMAL.

(3) Position TI controls as listed in (a) through (c) below:

(a) HORIZONTAL DISPLAY switch to INT SWEEP X1.

(b) SWEEP TIME switch to 1 μ SEC/CM.

(c) TRIGGER LEVEL control to 0 (zero).

(d) TRIGGER SOURCE switch to EXT AC.

(4) Turn vertical plug-in SENSITIVITY switch to 0.5 VOLT/CM.

(5) Connect test oscillator (A5) OUTPUT to vertical plug-in (A8) channel A INPUT connector and TI TRIG INPUT connector, using two cables and adapter (B6 and B3).

(6) Adjust test oscillator frequency to 1 MHz and amplitude for 1 cm of vertical deflection on TI. Adjust TI TRIGGER LEVEL control, if necessary, for a stable display.

(7) Slowly decrease test oscillator output until TI sweep stops; then, slowly increase output until sweep starts. TI vertical deflection will be 0.5 cm or less. If not, perform b(1) through (14) below.

(8) Turn TI TRIGGER SOURCE switch to EXT DC.

(9) Repeat (6) and (7) above, except, no adjustment can be made.

(10) Turn TI TRIGGER SOURCE switch to INT.

(11) Repeat (6) and (7) above. TI vertical deflection will be 0.2 cm or less.

(12) Substitute signal generator (A2) for test oscillator, using additional adapter (B1).

(13) Position TI controls as listed in (a) through (c) below:

(a) SWEEP TIME switch to .1 μ SEC/CM.

(b) HORIZONTAL DISPLAY switch to X10.

(c) TRIGGER SOURCE switch to EXT DC.

(14) Adjust signal generator frequency to 50 MHz and slowly increase output amplitude until TI triggers, while adjusting TI TRIGGER LEVEL control as required. TI vertical deflection will be 1 cm or less.

(15) Turn TRIGGER SOURCE switch to EXT AC.

(16) Repeat (14) above.

(17) Turn TRIGGER SOURCE switch to INT.

(18) Repeat (14) above. TI vertical deflection will be 2 cm or less.

b. Adjustments.

(1) Turn vertical plug-in SENSITIVITY switch to 0.05 VOLT/CM and TI TRIGGER SLOPE switch to - (negative).

(2) Disconnect test oscillator from vertical plug-in and connect test probe (supplied with TI) to vertical plug-in CHANNEL A INPUT connector.

NOTE

Leave test oscillator connected to TI TRIG INPUT connector.

(3) Connect TI test probe to case of CR102 (Fig. 3).

(4) Adjust test oscillator output to 0.05 volt rms.

(5) Adjust TI R116 (Fig. 3) to mechanical midrange and R120 (Fig. 3) fully clockwise.

(6) Adjust TRIGGER LEVEL control unit TI displays a free-running sweep of approximately 1-cm vertical deflection.

(7) Adjust R120 until TI displays a stable, synchronized, symmetrical square wave, approximately 0.7-cm vertical deflection.

NOTE

Adjust TRIGGER LEVEL control as necessary to maintain a presentation on TI.

(8) Adjust test oscillator to 0.03 volt rms. TI sweep will trigger intermittently. If sweep triggering is stable, adjust R120 counterclockwise until sweep triggers intermittently. (R)

(9) Repeat (4), (7), and (8) above until no further adjustments are necessary.

(10) Turn TI TRIGGER SLOPE switch to + (positive).

(11) Short the green/orange wire connected to TRIGGER SLOPE switch to chassis ground, using lead and two adapters (B9 and B2).

(12) Adjust R116 until TI displays symmetrical square wave. (R)

(13) Disconnect lead from TRIGGER SLOPE switch.

(14) Repeat a(4) and (5) above.

14. Sweep Time. a. Performance Check.

(1) Connect marker generator (A4) MARKER OUTPUT connector to vertical plugin (A9) channel A INPUT connector, using cable and termination (B6 and B12).

(2) Turn TI SWEEP TIME switch to 1 μsec/cm and HORIZONTAL DISPLAY switch to X1.

(3) Adjust marker generator output for 1 μsec positive-going markers.

(4) Adjust vertical plug-in SENSITIVITY switch and SENSITIVITY VERNIER control until TI vertical deflection is 3 cm.

(5) Adjust HORIZONTAL POSITION control to align first marker with first graticule line. Observe that TI displays 11 complete markers with marker 12 just starting at right edge of sweep. If not, perform b(1) below.

(6) Adjust marker generator output for 0.1-μsec markers.

(7) Turn TI SWEEP TIME switch to .1 μSEC/CM and adjust HORIZONTAL POSITION control until second marker coincides with second graticule line. Observe that tenth marker occurs within 0.3 cm of tenth graticule line. If not, perform b(2) below.

(8) Set marker generator for marker outputs listed in table 3. At each setting, adjust HORIZONTAL POSITION control to align second marker (1/div) or third marker (2/div) behind second graticule line. Tenth marker (1/div) or 19th marker (2/div) will be displayed within 0.3 cm of tenth graticule line. If not, perform appropriate adjustments listed in table 3.

Table 3. Sweep Time

TI SWEEPTIME switch settings	Marker generator settings	Markers per div.	Adjustments (fig. 3)
.2μSEC/CM	0.1 μsec	2	C1016(R)
.5 μSEC/CM	0.5 μsec	1	C1014(R)
1μSEC/CM	1 μsec	1	C1012(R)
2μSEC/CM	1 μsec	2	----
5μSEC/CM	5 μsee	1	----
10μSEC/CM	10 μsec	1	C1010(R)
20μSEC/CM	10 μsec	2	----
50μSEC/CM	50 μsec	1	----

Table 3. Sweep Time--Continued

TI SWEEPTIME switch settings	Marker generator settings	Markers per div	Adjustments (fig 3)
.1 mSEC/CM	0.1 msec	1	R1005(R)
.2 mSEC/CM	0.1 msec	2	----
.5 mSEC/CM	0.5 msec	1	----
1 mSEC/CM	1 msec	1	R1004(R)
2 mSEC/CM	1 msec	2	----
5 mSEC/CM	5 msec	1	----
10 mSEC/CM	10 msec	1	R1003(R)
20 mSEC/CM	10 msec	2	----
50 mSEC/CM	50 msec	1	----
.1 SEC/CM	0.1 sec	1	R1002(R)
.2 SEC/CM	0.1 sec	2	----
.5 SEC/CM	0.5 sec	1	----
1 SEC/CM	1 sec	1	----
2 SEC/CM	1 sec	2	----
5 SEC/CM	5 sec	1	----
.1 mSEC/CM*	10 μ sec	1	----

*Turn HORIZONTAL DELAY switch to X10.

b. Adjustments.

(1) Adjust R161 (fig. 3) until marker 12 just appears at the right edge of sweep. (R)

(2) Adjust C125 (Fig. 3) until tenth marker coincides with 10-cm graticule mark on TI. (R)

15. Vertical Amplifier Gain. a. Performance Check.

(1) Remove vertical plug-in (A8) from TI. Install test adapter (B4) in TI using P1 of test adapter.

(2) Connect voltage calibrator (A1) output terminals to test adapter J1 connector, using cable (B7).

(3) Turn TI HORIZONTAL DISPLAY to INT SWEEP X1 and SWEEP TIME switch to 1 mSEC/CM.

(4) Turn voltage calibrator function switch to P-P and adjust output until TI vertical deflection indicates 5 cm. Voltage calibrator will indicate between 0.97 and 1.03 volts pp. If not, perform b(1) and (2) below.

NOTE

Adjust test adapter BAL control for convenient vertical position.

b. Adjustments.

(1) Adjust voltage calibrator to 1.0 volt pp.

(2) Adjust R45 (Fig. 1) until TI vertical deflection indicates 5 cm. (R)

16. Scan Response. a. Performance Check.

(1) Remove test adapter (B4) from TI and install vertical plug-in (A8).

(2) Remove horizontal plug-in (A7) from TI and install test adapter.

(3) Connect equipment as shown in figure 4.

(4) Adjust square-wave generator (A3) frequency to 50 kHz and amplitude for 6-cm vertical

deflection on TI. Observe that square wave displayed on oscilloscope (A6) has flat top. If not, perform b(1) below.

(5) Disconnect test probe (B10) from pin 15 of test adapter and connect to pin 13. Observe that square wave displayed on oscilloscope has flat top. If not, perform b(2) below.

(6) Disconnect test probe from pin 13 of test adapter and connect to pin 10.

(7) Adjust square-wave generator frequency to 1MHz. Observe that balanced waveform B (Fig. 5) is displayed on oscilloscope. If not, perform b(3) below.

b. Adjustments.

(1) Adjust C36 (Fig. 1) for best square wave as displayed on oscilloscope.

(2) Adjust C37 (Fig. 1) for best square wave as displayed on oscilloscope.

(3) Adjust C33 (Fig. 1) for best balance (waveform B) (Fig. 5) as displayed on oscilloscope.

17. Vertical Pulse Response. a. Performance Check.

(1) Remove test adapter (B4) from TI and install horizontal plug-in (A7). Remove vertical plug-in (A8) and install test adapter.

NOTE

Replace two screw removed per previous note in paragraph 9a(2).

(2) Connect square-wave generator (A3) + (positive) OUTPUT connector to test adapter J1 connector, and square-wave generator - (negative) OUTPUT connector to test adapter J3 connector.

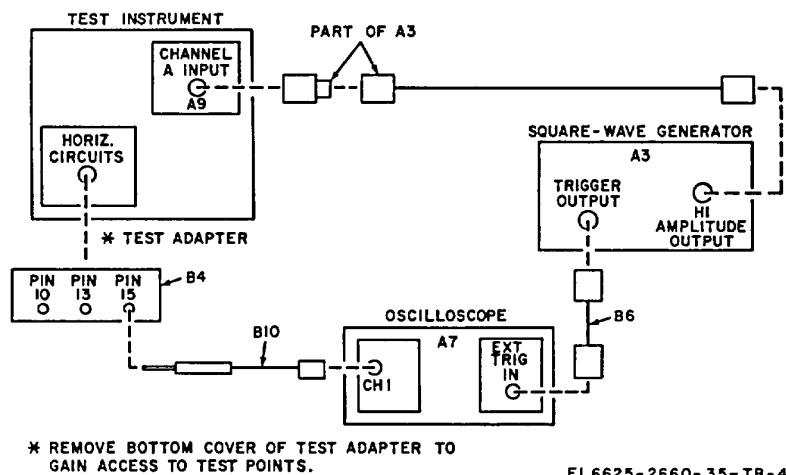

Figure 4. Oscilloscope scan response, equipment setup.

Use cables and terminations supplied with square-wave generator.

(3) Turn TI SWEEP TIME switch to .1 μ SEC/CM and HORIZONTAL DISPLAY switch to X10.

(4) Adjust square-wave generator repetition rate to 100 kHz, and positive and negative amplitude controls to produce a TI vertical deflection of 5 cm.

NOTE

Adjust test adapter BAL control for convenient viewing.

(5) Measure rise time. Rise time will be 7 nsec or less. If not, perform b below.

b. Adjustments.

(1) Turn SWEEP TIME switch to .5 μ SEC/CM and HORIZONTAL DISPLAY switch to X1.

(2) Adjust C22 (Fig. 1) until leading edge of square wave displayed on TI drops approximately 0.2 cm. (R)

(3) Adjust C35 (Fig. 1) to obtain best flat top of square wave displayed on TI. (R)

(4) Readjust C22 to obtain best leading edge of square wave displayed on TI.

(5) Repeat a(3) through (5) above.

18. Calibrator Accuracy. a. Performance Check.

(1) Remove test adapter (B4) from TI and install vertical plug-in (A8).

(2) Connect vertical plug-in channel A INPUT connector to TI CALIBRATOR 10 VOLTS terminals, using cable (B7).

(3) Turn TI SWEEP TIME switch to 0.5 mSEC/CM.

(4) Turn vertical plug-in SENSITIVITY switch to 1 VOLT/CM and adjust SENSITIVITY EL6625-2660-35-TB-5

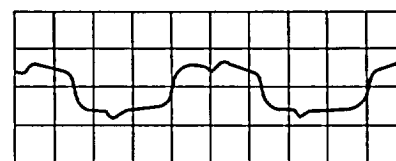

A
(UNBALANCED)

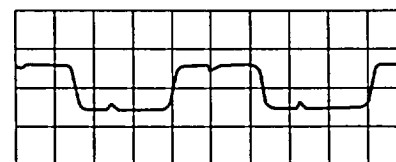

B
(BALANCED)

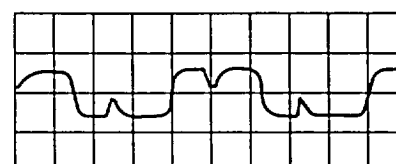

C
(UNBALANCED)

Figure 5. Delay generator, scan balance waveforms.

VERNIER control for exactly 6 cm of vertical deflection on TI.

NOTE

Adjust TI TRIGGER LEVEL as required for a stable display.

(5) Disconnect cable (B7) from TI CALIBRATOR 10 VOLTS terminals and connect to ac voltage calibrator (A9).

(6) Adjust voltage calibrator until TI vertical deflection is 6 cm. Ac power source will indicate between 3.499 and 3.570 volts rms. If not, perform b(1) through (4) below.

(7) Disconnect cable (B7) from ac voltage

calibrator and connect to TI CALIBRATOR 1 VOLT terminals.

(8) Turn vertical plug-in SENSITIVITY switch to .1 VOLT/CM and adjust SENSITIVITY VERNIER control for 6 cm of vertical deflection on TI.

(9) Disconnect cable (B7) from TI CALIBRATOR 1 VOLT terminals and connect to ac voltage calibrator.

(10) Adjust ac voltage calibrator until TI vertical deflection is 6 cm. Ac power source will indicate between 0.3499 and 0.3570 volt rms.

b. Adjustments.

(1) Adjust ac voltage calibrator output to 3.535 volts rms as indicated on ac-dc voltmeter.

(2) Repeat a(4) above.

(3) Repeat a(2) above.

(4) Adjust R375 (Fig. 1) until TI vertical deflection is 6 cm. (R)

19. Power Supplies.

NOTE

Do not perform power supply checks if all other parameters are within tolerance.

a. Performance Check.

(1) Remove vertical plug-in (A8) and install test adapter (B4).

(2) Connect ac/dc voltmeter (A12) between test adapter -100 and GND terminals. Ac/dc voltmeter will indicate between -97 and -103 volts dc. If not, perform b(1) below.

(3) Adjust autotransformer (A10) between 105 and 125 volts ac. Ac/dc voltmeter will indicate within limits specified in (2) above.

(4) Adjust autotransformer to 115 volts ac.

(5) Connect ac/dc voltmeter between adapter +110 and GND terminals. Ac/dc voltmeter will indicate between 107 and 113 volts dc. If not, perform b(2) below.

(6) Repeat (3) and (4) above. Ac/dc voltmeter will indicate within limits specified in (5) above.

(7) Connect ac/dc voltmeter between test adapter +370 and GND terminals. Ac/dc voltmeter will indicate between +360 and +380 volts dc. If not, perform b(3) below.

(8) Repeat (3) and (4) above. Ac/dc voltmeter will indicate within limits specified in (7) above.

(9) Connect ac/dc voltmeter between test adapter +6.3 and GND terminals. Ac/dc voltmeter will indicate between +6.1 and +6.5 volts dc. If not, perform b(4) below.

(10) Repeat (3) and (4) above. Ac/dc voltmeter will indicate within limits specified in (9) above.

(11) Connect ac/dc voltmeter between test adapter -6.3 and GND terminals. Ac/dc voltmeter will indicate between -6.1 and -6.5 volts dc. If not, perform b(5) below.

(12) Connect HV voltmeter (A12) between pin 1 to T401 (Fig. 3) and chassis ground. HV voltmeter will indicate between -2600 to -2800 volts dc (note indication). If not, perform b(6) below.

(13) Repeat (3) and (4) above. HV voltmeter will indicate within 25 volts of voltage noted in (12) above.

b. Adjustments.

(1) Adjust R472 (Fig. 3) until ac/dc voltmeter indicates -100 volts dc.

(2) Adjust R451 (Fig. 3) until ac/dc voltmeter indicates +110 volts dc.

(3) Adjust R433 (Fig. 3) until ac/dc voltmeter indicates +370 volts dc.

(4) Adjust R486 (Fig. 3) until ac/dc voltmeter indicates +6.3 volts dc.

(5) Adjust R486 (Fig. 3) for best compromise between -6.3 and +6.3 volts dc.

(6) Adjust R328 (Fig. 1) until HV voltmeter indicates -2700 volts dc.

NOTE

Refer to paragraph 63 for final procedure.

SECTION III
CALIBRATION PROCEDURE FOR VERTICAL AMPLIFIER, MODEL 1750A

20. Preliminary Procedure.

NOTE
Personnel should familiarize themselves with the entire bulletin prior to performing calibration.

- a. Install TI in vertical amplifier compartment of oscilloscope (A6).
- b. Install horizontal plug-in (A7) in oscilloscope.
- c. Connect oscilloscope to 115-volt ac source.
- d. Remove top and right side covers from oscilloscope.

e. Position TI and oscilloscope controls as listed in (1) through (8) below:

- (1) Vertical display switch to CHANNEL A.
- (2) Channel A and B VERTICAL POSITION controls centered.
- (3) HORIZONTAL DISPLAY switch to INT. SWEEP X1.
- (4) TRIGGER SOURCE switch to INT.
- (5) TRIGGER LEVEL control to 0 (zero).
- (6) SWEEP MODE switch to FREE RUN.
- (7) SWEEP TIME switch to 1 mSEC/CM.
- (8) SWEEP TIME VERNIER control to CAL.

f. Position applicable horizontal plug-in controls as follows:

- (1) Model 1780A: SWEEP OCCURRENCE switch to NORMAL.
- (2) Model 1781A/B: SWEEP SELECTOR switch to MAIN SWEEP.
- (3) Model 1782B: FUNCTION switch to OFF.

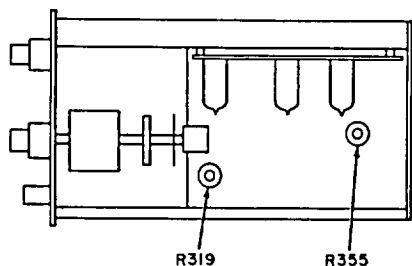

EL6625-2660-35-TB-6

Figure 6. Vertical amplifier, top view (model 1750A)

(4) Model 1783B: TIME MARKER switch to OFF.

g. Energize equipment and allow 30 minutes for TI to warm up and stabilize.

h. Adjust channel A front-panel BAL control until no vertical movement of trace is observed as TI SENSITIVITY (VOLTS/CM) VERNIER control is turned throughout its range.

i. Turn vertical display switch to CHANNEL B and repeat h above, using channel B BAL control.

j. Turn vertical display switch to ALTERNATE and adjust R319 (Fig. 6) until both traces are centered on crt.

k. Turn vertical display switch to CHOPPED. Position crt traces 5 cm apart, using VERTICAL POSITION controls. Adjust R355 (Fig. 6) for minimum trace widths.

WARNING

HIGH VOLTAGE is used during the performance of this procedure.

DEATH ON CONTACT

may result if personnel fail to observe safety precautions.

NOTE

When the TI is not within tolerance, perform the specified adjustment and continue the performance check. When the TI is not within tolerance and no adjustment is specified, the deficiency must be corrected before continuing with the procedure.

21. Gain and Sensitivity. a. Performance Check.

(1) Connect voltage calibrator (A1) to TI channel A INPUT connector, using cable (B7).

(2) Position channel A TI controls as listed in (a) through (e) below:

- (a) Vertical display switch to CHANNEL A.
- (b) SENSITIVITY (VOLTS/CM) switch to .05.
- (c) SENSITIVITY (VOLTS/CM) VERNIER control to CALIBRATED.

- (d) POSITION control to center trace.
- (e) AG-DC switch to AC.
- (3) Adjust voltage calibrator until TI vertical display is 6 cm. Voltage calibrator will indicate between 0.291 and 0.309 volt pp. If not, perform b below.
- (4) Connect voltage calibrator to TI channel B INPUT connector and repeat technique of (2) and (3) above, using TI channel B controls.
- (5) Adjust voltage calibrator for 4cm vertical deflection on oscilloscope. Voltage calibrator will

- indicate between 0.194 and 0.206 volt pp.
- (6) Repeat (5) above, using settings listed in table 4. Voltage calibrator indications will be within limits specified.
- (7) Repeat technique of (5) and (6) above, using channel A controls and input.
- b. *Adjustments.* Adjust voltage calibrator output to 0.3 volt pp and adjust channel A or channel B SENS. CAL control for 6-cm vertical deflection on oscilloscope.

Table 4. Vertical Sensitivity

TI channel A or B SENSITIVITY (VOLTS/CM) switch position	Oscilloscope vertical deflection (em)	Min	Max
.1	5	0.485 V pp	0.515 V pp
.2	5	0.970 V pp	1.030 V pp
.5	4	1.94 V pp	2.06 V pp
1	5	4.85 V pp	5.15 V pp
2*	5	3.429 V rms	3.641 V rms
5	4	6.858 V rms	7.282 V rms
10	5	17.145 V rms	18.205 V rms
20	5	34.289 V rms	36.411 V rms

*Connect ac voltage calibrator (A9) to TI INPUT connector using cable (B7). Adjust frequency to 1000 Hz.

22. Amplifier Input Capacitance. a. *Performance Check*

- (1) Connect HI AMPLITUDE OUTPUT connector of square-wave generator (A3) to TI channel B INPUT connector, using probe supplied with oscilloscope (A6).
- (2) Position TI and oscilloscope controls as listed in (a) through (f) below:
 - (a) Channel A SENSITIVITY (VOLTS/CM) switch to 5.
 - (b) Channel B SENSITIVITY (VOLTS/CM) switch to .05.
 - (c) Vertical display switch to CHANNEL B.
 - (d) Channel B POLARITY switch to +UP.
 - (e) SWEEP TIME switch to .2 mSEC/CM.
 - (f) SWEEP MODE switch to PRESET.

(3) Adjust square-wave generator for frequency of 1 kHz and a convenient vertical deflection on oscilloscope.

- (4) Standardize probe.
- (5) Turn channel B POLARITY switch to -UP. Optimum wave-form will be displayed on oscilloscope. If not, perform b(1) below.
- (6) Turn vertical display switch to A-B and channel A POLARITY switch to -UP. Optimum waveform will be displayed on oscilloscope. If not, perform b(2) below.
- (7) Turn channel A POLARITY switch to +UP. Optimum waveform will be displayed. If not, perform b(3) below.

(8) Turn vertical display switch to CHANNEL A and channel A SENSITIVITY (VOLTS/CM) switch to .05.

(9) Connect square-wave generator to TI channel A INPUT connector. Optimum waveform will be

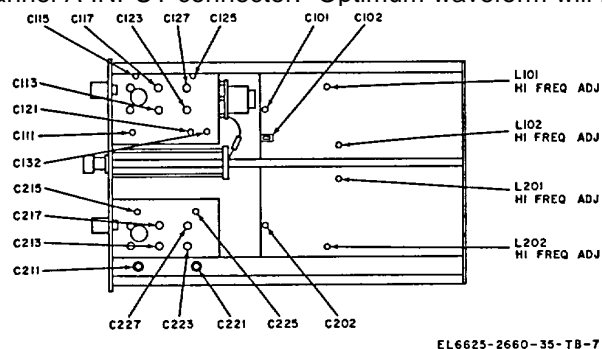

Figure 7. Vertical amplifier, right side view (Model 1750A).

displayed on oscilloscope. If not, perform b(4) below.

b. *Adjustments.* (Refer to figure 7 for the following adjustments.)

- (1) Adjust C202 for optimum square wave.
- (R) (2) Adjust C101 for optimum square wave.
- (R) (3) Adjust C102 for optimum square wave.
- (R) (4) Adjust C132 for optimum square wave.

23. Attenuator Compensation. a. *Performance Check.*

(1) Connect square-wave generator (A3) to TI channel A INPUT connector, using cable and termination

supplied with square-wave generator.

(2) Turn oscilloscope (A6) SWEEP TIME switch to 50 μSEC/CM.

(3) Adjust square-wave generator for 10-kHz output frequency.

(4) Turn SENSITIVITY (VOLTS/CM) switch to positions listed in table 5 while adjusting output level of square-wave generator as necessary for adequate deflection. Optimum waveform will be displayed on oscilloscope. If not, perform b below.

(5) Turn TI vertical display switch to CHANNEL B, POLARITY switch to +UP, and repeat (1) through (4) above for channel B.

b. *Adjustments.* Perform applicable adjustments listed in table 5.

Table 5. Attenuator Compensation

T1		
SENSITIVITY (VOLTS/CM)	Adjustments (Fig. 7)	
switch position	Channel A	Channel B
.1	C123(R)	C223(R)
.2	C127(R)	C227(R)
.5	C113(R)	C213(R)
1	C121(R)	C221(R)
2	C125(R)	C225(R)
5	C117(R)	C217(R)
10		
20		

24. Attenuator Input Capacitance. a. *Performance Check.*

(1) Connect square-wave generator (A3) HI AMPLITUDE OUTPUT connector to channel A INPUT connector, using probe supplied with oscilloscope (A6).

(2) Position TI channel A and oscilloscope controls as listed in (a) through (c) below:

(a) Vertical display switch to CHANNEL A.

(b) SENSITIVITY VOLTS/CM switch to .05.

(c) SWEEP TIME switch to .5 mSEC/CM.

(3) Adjust square-wave generator frequency to 1 kHz and output for convenient display on oscilloscope.

(4) Standardize probe.

(5) Turn SENSITIVITY (VOLTS/CM) switch to positions listed in table 6 while adjusting output level of square-wave generator as necessary. Optimum

waveform will be displayed on oscilloscope. If not, perform b below.

(6) Repeat (1), (2), (3), and (5) above for channel B.

b. *Adjustments.* Perform applicable adjustments listed in table 6.

Table 6. Attenuator Input Capacitance

T1		
SENSITIVITY (VOLTS/CM)	Adjustment (Fig. 7)	
switch position	Channel A	Channel B
.5	C111(R)	C211(R)
5	C115(R)	C215(R)

25. Pulse Response. a. *Performance Check.*

(1) Connect FAST RISE+ OUTPUT connector of square-wave generator (A3) to TI channel A input, using termination and cable supplied with square-wave generator.

(2) Position TI channel A and oscilloscope (A6) controls as listed in (a) through (b) below:

(a) Vertical display switch to CHANNEL A.

(b) SENSITIVITY (VOLTS/CM) switch to .05.

(c) SWEEP TIME switch to .1 μSEC/CM.

(d) HORIZONTAL DISPLAY switch to INT SWEEP X10.

(3) Measure rise time, using standard rise-time technique at square-wave generator frequency of 1 MHz. Rise time will be less than 9 nsec. Overshoot will be less than 1 percent. If not, perform b(l) below.

(4) Repeat technique of (1) through (3) above for channel B. Rise time will be less than 9 nsec and overshoot will be less than 1 percent. If not, perform b(2) below.

b. *Adjustments.*

(1) Adjust L101 and L102 (Fig. 7) for rise time of 9 nsec or less with overshoot of less than 1 percent. (R)

(2) Adjust L201 and L202 (Fig. 7) for rise time of 9 nsec or less with overshoot of less than 1 percent. (R)

NOTE

Refer to paragraph 63 for final procedure.

SECTION IV

**CALIBRATION PROCEDURE FOR VERTICAL
AMPLIFIER, MODEL 1750B (AM-4031A/U)**

26. Preliminary Procedure.**NOTE**

Personnel should familiarize themselves with the entire bulletin prior to performing calibration.

- a. Install TI in vertical amplifier compartment of oscilloscope (A6).
- b. Install horizontal plug-in (A7) in oscilloscope.
- c. Connect oscilloscope to 115-volt ac source.
- d. Remove top and right side covers from oscilloscope.
- e. Position TI and oscilloscope controls as listed in (1) through (8) below:
 - (1) Vertical display switch to CHANNEL A.
 - (2) Channel A and channel B VERTICAL POSITION controls centered.
 - (3) HORIZONTAL DISPLAY switch to INT. SWEEP X1.
 - (4) TRIGGER SOURCE switch to INT.
 - (5) TRIGGER LEVEL control to 0 (zero).
 - (6) SWEEP MODE switch to FREE RUN.
 - (7) SWEEP TIME switch to 1 mSEC/CM.
 - (8) SWEEP TIME VERNIER control to CAL.
- f. Position applicable horizontal plug-in controls as follows:
 - (1) Model 1780A: SWEEP OCCURRENCE switch to NORMAL.
 - (2) Model 1781B: SWEEP SELECTOR switch to Main Sweep.
 - (3) Model 1782B: FUNCTION switch to OFF.
 - (4) Model 1783B: TIME MARKER switch to OFF.
- g. Energize equipment and allow 30 minutes for TI to warm up and stabilize.
- h. Adjust channel A DC BAL control until no vertical movement of trace is observed as TI SENSITIVITY (V/CM) vernier is rotated throughout its range.
- i. Turn vertical display switch to CHANNEL B and repeat (h) above, using channel B DC BAL control.
- j. Turn vertical display switch to CHANNEL A and center trace, using channel A POSITION control. Turn

vertical display switch to CHANNEL B and center trace, using channel B POSITION control.

k. Turn vertical display switch to A + B and adjust A + B BAL control to center trace vertically on oscilloscope.

WARNING

HIGH VOLTAGE is used during the performance of this procedure.

DEATH ON CONTACT

may result if personnel fail to observe safety precautions.

NOTE

When the TI is not within tolerance, perform the specified adjustment and continue the performance check. When the TI is not within tolerance and no adjustment is specified, the deficiency must be corrected before continuing with the procedure.

27. Gain and Sensitivity. a. Performance Check.

- (1) Connect voltage calibrator (A1) to TI CHANNEL A INPUT connector, using cable (B7).
- (2) Position channel A TI controls as listed in (a) through (e) below:
 - (a) Vertical display switch CHANNEL A.
 - (b) SENSITIVITY (V/CM) switch to .05.
 - (c) VERNIER control to CAL.
 - (d) POSITION control to center trace.
 - (e) AC/DC switch to AC.
- (3) Adjust voltage calibrator output until TI vertical display is 6 cm.
- (4) Voltage calibrator will indicate between 0.291 and 0.309 volt pp. If not, perform b below.
- (5) Connect voltage calibrator to TI CHANNEL B INPUT connector and repeat technique of (2) through (4) above, using TI channel B controls.
- (6) Adjust voltage calibrator for 4-cm vertical deflection on oscilloscope. Voltage calibrator will indicate between 0.194 and 0.206 volt pp.

(7) Repeat (6) above, using settings listed in table 7. Ac voltage calibrator indications will be within limits specified.

(8) Repeat technique of (6) and (7) above, using channel A controls and input.

Table 7. Vertical Sensitivity

TI channel A or B SENSITIVITY (V/CM) switch position	Oscilloscope vertical deflection (cm)	Voltage calibrator	
		Min	Max
.1	5	0.485 V pp	0.515 V pp
.2	5	0.970 V pp	1.030 V pp
.5	4	1.94 V pp	2.06 V pp
1*	5	4.85 V pp	5.15 V pp
2	5	3.429 V rms	3.641 V rms
5*	4	6.858 V rms	7.282 V rms
10	5	17.145 V rms	18.205 V pp
20	5	34.289 V rms	36.411 V rms

*Connect ac voltage calibrator (A9) to TI INPUT connector using cable (B7). Adjust frequency to 1000 Hz.

b. *Adjustments.* Adjust voltage calibrator output to 0.3 v peak to peak and adjust channel A or channel B SENS. CAL control for 6-cm vertical deflection on oscilloscope.

28. Attenuator Compensation. a. *Performance Check.*

(1) Connect HI AMPLITUDE OUTPUT connector of square-wave generator (A3) to channel A INPUT connector, using termination and cable supplied with square-wave generator.

(2) Position TI vertical display switch to CHANNEL A and oscilloscope (A6) SWEEP TIME switch to 50 μSEC/CM.

(3) Adjust square-wave generator for 10 kHz output frequency.

(4) Turn SENSITIVITY (V/CM) switch to positions listed in table 8 while adjusting output level of square-wave generator as necessary for adequate deflection. Optimum waveform will be displayed on oscilloscope. If not, perform b below.

(5) Turn TI vertical display switch to CHANNEL B and repeat (1) through (4) above.

b. *Adjustments.* Perform applicable adjustments (Fig. 8) listed in table 8.

Table 8. Attenuator Compensation

TI SENSITIVITY (V/CM) switch position	Adjustments (fig 8)	
	Channel A	Channel B
.1	C112 (R)	C212 (R)
.2	C118 (R)	C218 (R)
.5	C104 (R)	C204 (R)
1	C111 (R)	C211 (R)
2	C117 (R)	C217 (R)
5	C108 (R)	C208 (R)
10		
20		

29. Attenuator Input Capacitance. a. *Performance Check.*

(1) Connect square-wave generator (A3) HI AMPLITUDE OUTPUT connector to channel A INPUT connector, using probe supplied with oscilloscope (A6).

(2) Position TI channel A and oscilloscope controls as listed in (a) through (c) below:

- (a) Vertical display switch to CHANNEL A.
- (b) SENSITIVITY (V/CM) switch to .05.
- (c) SWEEP TIME switch to .5 mSEC/CM.

(3) Adjust square-wave generator frequency to 1 kHz and output for a convenient display on oscilloscope.

(4) Standardize probe.

(5) Turn SENSITIVITY (V/CM) switch to positions listed in table 9 while adjusting output level of square-wave generator as necessary for adequate deflection. Optimum waveform will be displayed on oscilloscope. If not, perform b below.

(6) Repeat (1), (2), (3), and (5) above for channel B.

b. *Adjustments.* Perform applicable adjustments listed in table 9.

30. Pulse Response. a. *Performance Check.*

(1) Connect FAST RISE + OUTPUT connector of square-wave generator (A3) to TI channel A input, using termination and cable supplied with square-wave generator.

Table 9. Attenuator Input Capacitance

TI SENSITIVITY (V/CM) switch position	Adjustments (fig 8)	
	Channel A	Channel B
.5	C102 (R)	C202 (R)
5	C106 (R)	C206 (R)

(2) Position TI channel A and oscilloscope (A6) controls as listed in (a) through (d) below:

- (a) Vertical display switch to CHANNEL A.
- (b) SENSITIVITY (V/CM) switch to .05.
- (c) SWEEP TIME switch to .1 μSEC/CM.
- (d) HORIZONTAL DISPLAY switch to INT SWEEP X10.

(3) Measure rise time, using standard risetime technique, and using square-wave

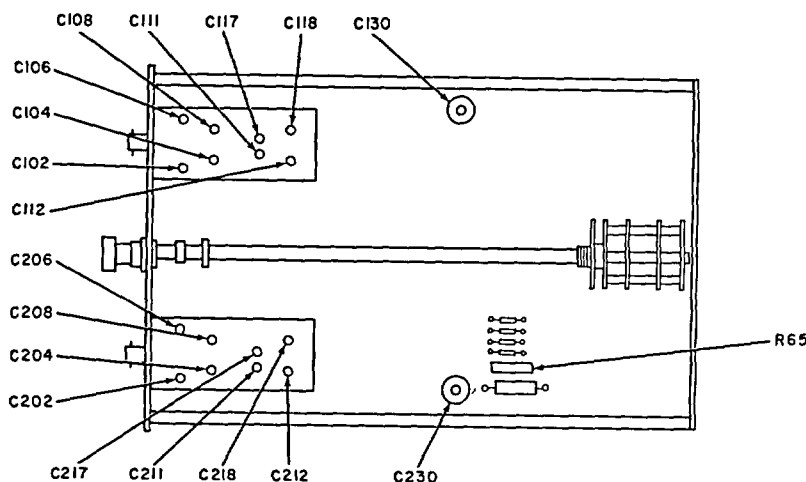

EL6625-2660-35-TB-8

Figure 8. Vertical amplifier right side view (Model 1750B).

generator frequency of 1MHz. Rise time will be less than 8 nsec. Overshoot will be less than 2 percent. If not, perform *b(1)* below.

(4) Repeat technique of (1) through (3) above for channel B. Rise time will be less than 8 nsec and overshoot will be less than 2 percent. If not, perform *b(2)* below.

b. Adjustments.

(1) Adjust C130 (Fig. 8) for rise time of 8 nsec or less with overshoot of less than 2 percent. (R)

(2) Adjust C230 (Fig. 8) for rise time of 8 nsec or less with overshoot of less than 2 percent. (R)

31. B Trigger Output Sensitivity and Dc Level. *a. Performance Check.*

(1) Connect voltage calibrator (A1) to TI channel B INPUT connector, using cable (B7).

(2) Connect TI B TRIG OUT connector to oscilloscope (A6) TRIG INPUT connector, using cable (B6).

(3) Position TI and oscilloscope controls as listed in (a) through (e) below:

- (a) Vertical display switch to CHANNEL B.
- (b) Channel B SENSITIVITY (V/CM) switch to 1.
- (c) SWEEP TIME switch to 5 mSEC/CM.
- (d) TRIGGER SOURCE switch to EXT AC.
- (e) SWEEP MODE switch to PRESET.
- (4) Adjust voltage calibrator output level until trace is obtained on oscilloscope.
- (5) Reduce output level until trace disappears.
- (6) Increase voltage calibrator output just enough to obtain stable trace. Vertical deflection will be 0.5 cm or less.
- (7) Disconnect cable (B6) from oscilloscope TRIG INPUT connector.
- (8) Turn vertical display switch to CHANNEL A and center trace, using channel A POSITION control.
- (9) Connect cable to channel A INPUT connector.

Trace will remain centered. If not, perform b below.

b. *Adjustments.* Adjust R65 (Fig. 8) to center trace.

NOTE

Refer to paragraph 63 for final procedure.

SECTION V
CALIBRATION PROCEDURE FOR VERTICAL AMPLIFIER, MODEL
1752A

32. Preliminary Procedure.**NOTE**

Personnel should familiarize themselves with the entire bulletin prior to performing calibration.

- a. Install TI in vertical amplifier compartment of oscilloscope (A6).
- b. Install horizontal plug-in (A7) in oscilloscope.
- c. Connect oscilloscope to 115-volt ac source.
- d. Remove right side cover from oscilloscope.
- e. Position TI and oscilloscope controls as listed in (1) through (8) below:
 - (1) VERTICAL DISPLAY switch to INPUT A, DC.
 - (2) SENSITIVITY (VOLTS/CM) switch to .05.
 - (3) SENSITIVITY (VOLTS/CM) VERNIER control to Cal.
 - (4) HORIZONTAL DISPLAY switch to INT. SWEEP X1.
 - (5) TRIGGER SOURCE switch to INT.
 - (6) SWEEP MODE switch to PRESET.
 - (7) SWEEP TIME switch to 1 MS/CM.
 - (8) SWEEP TIME VERNIER control to CAL.
- f. Position applicable horizontal plug-in controls as follows:
 - (1) Model 1780A: SWEEP OCCURRENCE switch to NORMAL.
 - (2) Model 1781A/B: SWEEP SELECTOR switch to MAIN SWEEP.
 - (3) Model 1782B: FUNCTION switch to OFF.
 - (4) Model 1783B: TIME MARKER switch to OFF.
- g. Energize equipment and allow 30 minutes for equipment to warm up and stabilize.
- h. Center trace, using POSITION controls.

NOTE

Adjust oscilloscope POSITION and TI POSITION controls as required throughout this bulletin.

- i. Adjust DC BALANCE control for minimum vertical shift of sweep trace while turning SENSITIVITY (VOLTS/CM) switch from .05 to .005.

WARNING

HIGH VOLTAGE is used during the performance of this procedure.

DEATH ON CONTACT

May result if personnel fail to observe safety precautions.

NOTE

When the TI is not within tolerance, perform the specified adjustment and continue the performance check. When the TI is not within tolerance and no adjustment is specified, the deficiency must be corrected before continuing with the procedure.

33. Gain and Sensitivity. a. Performance Check.

- (1) Connect voltage calibrator (A1) to TI INPUT A connector, using cable (B7).
 - (2) Turn SENSITIVITY (VOLTS/CM) control to .05.
 - (3) Adjust voltage calibrator output for a 4-cm vertical deflection on oscilloscope (A6). Voltage calibrator will indicate between 0.194 and 0.206 volt pp. If not, perform b below.
 - (4) Repeat technique of (3) and (4) above, using settings listed in table 10. Voltage calibrator or ac voltmeter (A1) indications will be within limits specified.
- b. Adjustments.* Adjust output of voltage calibrator to 0.2 volt pp and adjust SENS. CAL control for 4-cm vertical deflection on oscilloscope.

34. Attenuator Compensation. a. Performance Check.

- (1) Connect TI to oscilloscope (A6) using plug-in extender (B11).
- (2) Connect +(plus) OUTPUT connector of square-wave generator (A3) to INPUT A, using

termination and cable supplied with square-wave generator.

(3) Turn oscilloscope SWEEP TIME to 50 μ SEC/CM.

(4) Adjust square-wave generator for 10 kHz output frequency.

(5) Turn SENSITIVITY (VOLTS/CM) switch to positions listed in table 11 while adjusting output level of square-wave generator as necessary for adequate display. Optimum waveform will be displayed on oscilloscope. If not, perform b below.

b. *Adjustments.* Perform applicable adjustments (Fig. 9) as listed in table 11.

Table 10. Vertical Sensitivity

TI SENSITIVITY (VOLTS/CM) switch position	Oscilloscope vertical deflection (cm)	Voltage calibrator Indication	
		Min	Max
.005	4	19.4 mV pp	20.6 mV pp
.01	5	48.5 mV pp	51.5 mV pp
.02	5	97.5 mV pp	103 mV pp
.1	5	485 mV pp	515 mV pp
.2	5	970 mV pp	1030 mV pp
.5	4	1940 mV pp	2060 mV pp
1	5	4850 mV pp	5150 mV pp
2*	5	3.429 V rms	3.641 V rms
5	4	6.858 V rms	7.282 V rms
10	5	17.145 V rms	18.205 V rms
20	5	34.289 V rms	36.411 V rms

*Connect ac voltage calibrator (A9) to TI INPUT connector using cable (B7). Adjust frequency to 1000 Hz.

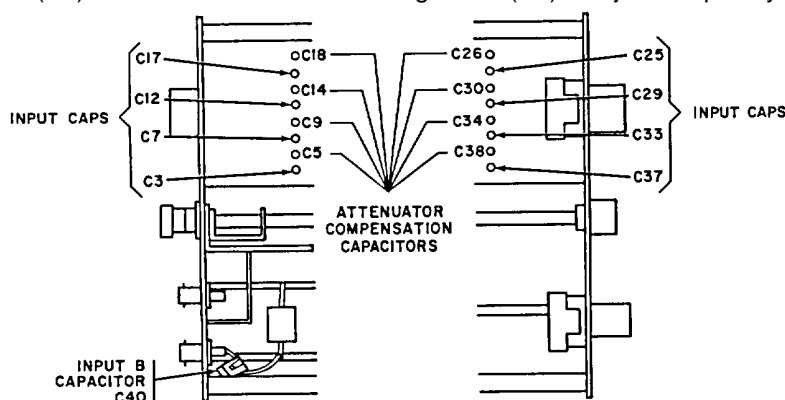

EL6625-2660-35-TB-9

Figure 9. Vertical amplifier, partial left- and right-side views, (Model 1752A).

Table 11. Attenuator Compensation

TI SENSITIVITY (VOLTS/CM) switch position	Adjustments (fig 9)
.1	C5(R)
.2	C9(R)
.5	C14(r)
1*	C18(R)
2	C26(R)
5	C30(R)
10	C34(R)
20	C38(R)

(2) Turn TI SENSITIVITY (VOLTS/CM) switch to .05 and oscilloscope SWEEP TIME switch to .5 mSEC/CM.

(3) Adjust square-wave generator frequency to 1 kHz while adjusting amplitude and TI VERNIER control as necessary for adequate display amplitude.

(4) Standardize probe.

(5) Turn SENSITIVITY (VOLTS/CM) switch to positions listed in table 12 while adjusting output level of square-wave generator as necessary. Optimum waveform will be displayed on oscilloscope. If not, perform b(1) below.

(6) Disconnect probe from INPUT A and connect to INPUT B.

(7) Turn TI SENSITIVITY switch to .05 VOLTS/CM and VERTICAL DISPLAY switch to INPUT B, DC.

(8) Repeat (3) above. Optimum waveform

*Use square-wave generator HI AMPLITUDE output.

35. Attenuator Input Capacitance. a. *Performance Check.*

(1) Connect square-wave generator (A3) HI AMPLITUDE OUTPUT connector to INPUT A connector, using probe supplied with oscilloscope (A6).

will be displayed on oscilloscope. If not, perform b(2) below.

(9) Turn VERTICAL DISPLAY switch to DIFFERENTIAL (A-B), DC.

(10) Repeat (3) above. Optimum waveform will be displayed on oscilloscope. If not, perform b(3) below.

b. Adjustments.

(1) Perform applicable adjustments listed in table 12.

Table 12. Attenuator Input Capacitance

TI SENSITIVITY (VOLTS/CM) switch position	Adjustments (fig 9)
.1	C3 (R)
.2	C7 (R)
.5	C12(R)
1	C17(R)
2	C25(R)
5	C29(R)
10	C33(R)
20	C37(R)

(2) Adjust C40 (Fig. 9) for optimum waveform.

(3) Adjust C46 (Fig. 10) for optimum waveform.

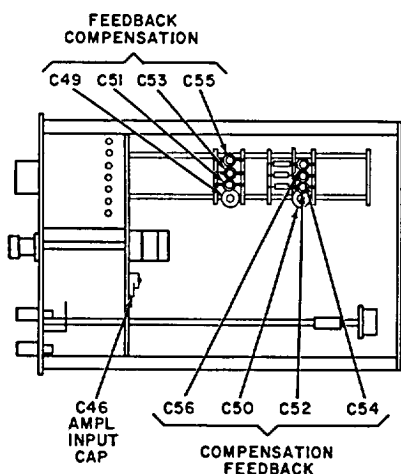

EL6625-2660-35-TB-10

Figure 10. Vertical amplifier, right-side view (Model 1725A).

36. Pulse Response . a. Performance Check.

(1) Remove plug-in extender (B11) and install TI in vertical compartment of oscilloscope (A6).

(2) Connect FAST RISE + OUTPUT connector of square-wave generator (A3) to TI channel A input, using termination and cable supplied with square-wave generator.

(3) Position TI and oscilloscope controls as listed in (a) through (d) below:

(a) VERTICAL DISPLAY switch to INPUT A, DC.

(b) SENSITIVITY (VOLTS/CM) switch to .005.

(c) SWEEP TIME switch to .1 μSEC/CM.

(d) HORIZONTAL DISPLAY switch to X10.

(4) Adjust square-wave generator frequency to 1 MHz and amplitude for a convenient display on oscilloscope.

(5) Measure rise time, using standard rise-time technique. Rise time will be 19 nsec or less. Overshoot, ringing, or other spurious responses will be less than 2 percent. If not, perform b below.

(6) Repeat technique of (4) and (5) above at TI SENSITIVITY (VOLTS/CM) switch positions listed in table 13. If rise time is greater than listed and spurious responses are greater than 2 percent, perform appropriate adjustments listed in table 13.

b. Adjustments. Adjust C49 and C50 (Fig. 10) for rise time of 19 nsec or less with spurious responses of less than 2 percent.

NOTE

Refer to paragraph 63 for final procedure.

Table 13. Rise Time

TI SENSITIVITY (VOLTS/CM) switch position	Rise time (nsec)	Adjustments (fig 10)
.01	19	C51 and C52(R)
.02	19	C53 and C54(R)
.05	14	C55 and C56(R)

SECTION VI

CALIBRATION PROCEDURE FOR VERTICAL AMPLIFIER, MODEL 1754A

37. Preliminary Procedure.

NOTE

Personnel should familiarize themselves with the entire bulletin prior to performing calibration.

a. Install TI in vertical amplifier compartment of oscilloscope (A6).

b. Install horizontal plug-in (A7) in oscilloscope.

c. Connect oscilloscope to 115-volt ac source.

d. Remove right-side cover from oscilloscope.

e. Position oscilloscope controls as listed in (1) through (6) below:

(1) HORIZONTAL DISPLAY switch to INT.

SWEEP XI.

(2) TRIGGER SOURCE switch to INT.

(3) SWEEP MODE switch to FREE RUN.

(4) SWEEP TIME switch to 1 mSEC/CM.

(5) SWEEP TIME VERNIER control to CAL.

(6) POWER switch to ON.

f. Position TI controls as listed in (1) through (4) below:

(1) Channel A MODE switch to ON.

(2) Channel B, C, and D MODE switches to

OFF.

(3) Channel A, B, C, and D VERTICAL SENSITIVITY (V/CM) switches to .05.

(4) Channel AP, B, C, and D AC-DC switches to AC.

g. Position applicable horizontal plug-in controls as follows:

(1) Model 1780A: SWEEP OCCURRENCE switch to NORMAL.

(2) Model 1781A/B: SWEEP SELECTOR switch to MAIN SWEEP.

(3) Model 1782B: FUNCTION switch to OFF.

(4) Model 1783B: TIME MARKER switch to

OFF.

h. Adjust oscilloscope TRIGGER LEVEL, HORIZONTAL POSITION, and TI channel A POSITION controls for a trace centered on oscilloscope crt.

NOTE

Adjust oscilloscope HORIZONTAL POSITION and TI applicable

POSITION controls as required throughout this bulletin.

i. Adjust channel A DC BAL control until no vertical movement of trace is observed as channel A SENSITIVITY (V/CM) VERNIER control is turned throughout its range.

j. Repeat i above for channel B, C, and D MODE switches and DC BAL controls.

WARNING

HIGH VOLTAGE is used during the performance of this procedure. DEATH ON CONTACT may result if personnel fail to observe safety precautions.

NOTE

When the TI is not within tolerance, perform the specified adjustment and continue the performance check. When the TI is not within tolerance and no adjustment is specified, the deficiency must be corrected before continuing with the procedure.

38. Gain and Sensitivity. a. Performance Check.

(1) Connect voltage calibrator (A1) to TI INPUT A connector, using cable (B7).

(2) Position TI controls as listed in (a) through (c) below:

(a) Channel A MODE switch to ON.

(b) Channel B, C, and D, MODE switches to OFF.

(c) Channel A, B, C, and D VERTICAL SENSITIVITY (V/CM) VERNIER controls to CAL.

(3) Adjust voltage calibrator output for 6-cm vertical deflection on oscilloscope (A6).

(4) Voltage calibrator will indicate between 0.291 and 0.309 volt pp. If not, perform b below.

(5) Repeat technique of (1) through (4) above, in turn, for channels B, C, and D.

(6) Repeat (1) and (2) above.

(7) Turn channel A VERTICAL SENSITIVITY (V/CM) switch to positions listed in table 14 while adjusting voltage calibrator output for oscilloscope vertical deflections as indicated. Voltage calibrator will indicate within limits specified.

(8) Repeat technique of (6) and (7) above, in turn, for channels B, C, and D.

b. Adjustments. Adjust voltage calibrator output to 0.3 v pp and adjust channel A, B, C, or D SENS CAL control as applicable for 6-cm vertical deflection on oscilloscope.

Table 14. Vertical Sensitivity

TI channel A, B, C, or D VERTICAL SENSITIVITY (V/CM) switch position	Oscilloscope vertical deflection (cm)	Voltage calibrator indication	
		Min	Max
.1	5	0.485 V pp	9.515 V pp
.2	5	0.970 V pp	1.030 V pp
.5	4	1.940 V pp	2.060 V pp
1	5	4.850 V pp	5.150 V pp
2	5	3.429 V rms	3.641 V rms
5*	4	6.858 V rms	7.282 V rms
10	5	17.145 V rms	18.205 V rms
20	5	34.289 V rms	36.411 V rms

*Connect ac voltage calibrator (A9) to TI INPUT connector using cable (B7). Adjust frequency to 1000 Hz.

(a) Channel D MODE switch to OFF.

(b) Channel A MODE switch to ON.

(c) Oscilloscope SWEEP MODE switch to PRESET.

(d) Oscilloscope SWEEP TIME switch to 50 μSEC/CM.

(4) Adjust square-wave generator for 10-kHz output frequency.

(5) Turn Channel A VERTICAL SENSITIVITY (V/CM) switch to positions listed in table 15 while adjusting output level of square-wave generator as necessary for adequate deflection. Optimum wave form will be displayed on oscilloscope. If not, perform b below.

(6) Repeat technique of (2) through (5) above, in turn, for channels B, C, and D, using respective channel controls.

b. Adjustments. Perform applicable adjustments (Fig. 11) listed in table 15.

40. Attenuator Input Capacitance. *a. Performance Check.*

(1) Connect square-wave generator (A3) HI AMPLITUDE OUTPUT connector to INPUT A connector, using probe supplied with oscilloscope (A6).

(2) Position TI and oscilloscope controls as listed in (a) through (d) below:

(a) Channel D MODE switch to OFF.

(b) Channel A MODE switch to ON.

(c) Channel A VERTICAL SENSITIVITY (V/CM) switch to .05.

39. Attenuator Compensation. *a. Performance Check.*

(1) Connect TI to oscilloscope (A6), using plug-in extender (B11).

(2) Connect HI AMPLITUDE OUTPUT connector of square-wave generator (A3) to INPUT A connector, using termination and cable supplied with square-wave generator.

(3) Position TI and oscilloscope controls as listed in (a) through (d) below:

(d) Oscilloscope SWEEP TIME switch to .5 mSEC/CM.

(3) Adjust square-wave generator frequency to 1 kHz and output amplitude for convenient display on oscilloscope.

(4) Standardize probe.

(5) Turn channel A VERTICAL SENSITIVITY (V/CM) switch to positions listed in table 16 while adjusting output level of square-wave generator as necessary. Optimum waveform will be displayed on oscilloscope. If not, perform b below.

(6) Repeat technique of (1) and (5) above for channels B, C, and D, using respective channel controls.

b. Adjustments. Perform applicable adjustments listed in table 16.

41. Pulse Response. *a. Performance Check.*

(1) Remove plug-in extender (B11) and install TI in vertical compartment of oscilloscope (A6).

(2) Connect FAST RISE + OUTPUT connector of square-wave generator (A3) to TI input A, using termination and cable supplied with square-wave generator.

(3) Position TI channel A and oscilloscope controls as listed in (a) through (d) below:

(a) Channel A MODE switch to ON.

(b) VERTICAL SENSITIVITY (V/CM) switch to .05.

(c) SWEEP TIME switch to .1 μSEC/CM.

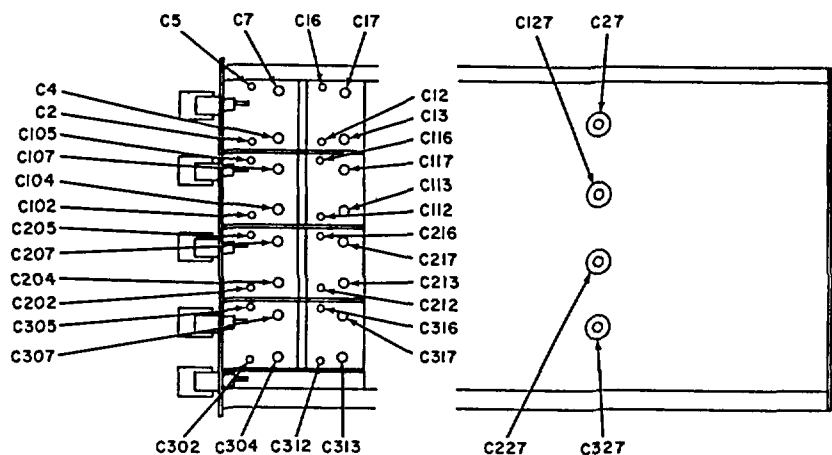

EL6625-2660-35-TB-11

Figure 11. Vertical amplifier, adjustment location (model 1754A).

Table 15. Attenuator Compensation

TI VERTICAL SENSITIVITY (VICM) switch position	Adjustments (Fig. 11)			
	Channel A	Channel B	Channel C	Channel D
.1	C13 (R)	C113 (R)	C213 (R)	C313 (R)
.2	C17 (R)	C117 (R)	C217 (R)	C317 (R)
.5	C4 (R)	C104 (R)	C204 (R)	C304 (R)
1	C12 (R)	C112 (R)	C212 (R)	C312 (R)
2	C16 (R)	C116 (R)	C216 (R)	C316 (R)
5	C7 (R)	C107 (R)	C207 (R)	C307 (R)

X10. (d) HORIZONTAL DISPLAY switch to (4) Adjust square-wave generator frequency to 1 MHz and amplitude for a convenient display on oscilloscope.

(5) Measure rise time, using standard risetime technique. Rise time will be less than 9 nsec. If not, perform b below.

Table 16. Attenuator Input Capacitance

TI VERTICAL SENSITIVITY (V/C V) switch position	Adjustments (fig. 11)			
	Channel A	Channel B	Channel C	Channel D
.5	C2 (R)	C102 (R)	C202 (R)	C302 (R)

(6) Repeat technique of (2) through (5) above for channels B, C, and D. Rise time will be less than 9 nsec for each channel. If not, perform applicable adjustment in b below.

- (2) Channel B-C127 (R).
- (3) Channel C-C227 (R).
- (4) Channel D-C327 (R).

b. Adjustments. Adjust capacitors (Fig. 11) listed below for best rise time and minimum overshoot:

- (1) Channel A-C 27 (R).

NOTE
Refer to paragraph 63 for final procedure.

SECTION VII

CALIBRATION PROCEDURE FOR DELAY GENERATOR, MODEL 1781A

42. Preliminary Procedure.

NOTE
Personnel should familiarize themselves with the entire bulletin prior to performing calibration.

- a. Remove bottom and side covers from oscilloscope. (A6).
- b. Insert TI and vertical plug-in (A8) into oscilloscope.
- c. Connect oscilloscope to 115 vac power source.
- d. Energize equipment and allow sufficient time for equipment to warmup and stabilize.

WARNING
HIGH VOLTAGE is used during the performance of this procedure. DEATH ON CONTACT may result if personnel fail to observe safety precautions.

NOTE
When the TI is not within tolerance, perform the specified adjustment and continue the performance check. When the TI is not within tolerance and no adjustment is specified, the deficiency must be corrected before continuing with the procedure.

43. Trigger Symmetry. a. Performance Check.

- (1) Connect test oscillator (A5) output to vertical plug-in (A8) vertical INPUT connector, using cable (B6).
- (2) Position TI controls as listed in (a) through (e) below:
 - (a) TRIGGER SLOPE switch to + (positive).
 - (b) TRIGGER SOURCE switch to INT.
 - (c) SWEEP MODE switch to PRESET.
 - (d) DELAYING SWEEP TIME/CM switch to .5 MILLISECONDS.
 - (e) SWEEP SELECTOR switch to DELAYING SWEEP.
- (3) Adjust test oscillator for 1 kHz and output for 2 mm of deflection on oscilloscope crt.

(4) Adjust TI TRIGGER LEVEL control for triggered sweep on oscilloscope crt.

(5) Turn TI TRIGGER SLOPE switch to (negative). Sweep will remain triggered. If not, perform b below.

b. Adjustments.

- (1) Connect pin 7 to V1 (Fig. 12) to ground, using lead with two adapters (B9 and B2).
- (2) Adjust R16 (Fig. 13) to give triggered sweep.
- (3) Disconnect lead with adapters from pin 7 of V1 and ground.

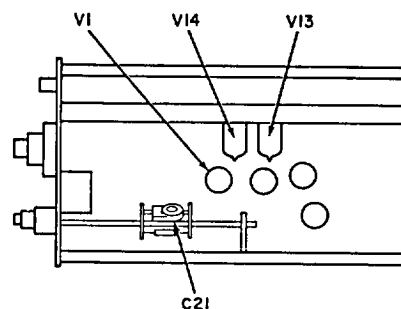

EL 6625-2660-35-TB-12

Figure 12. Delay generator, top view (model 1781A).

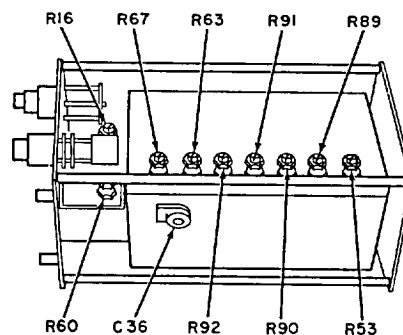

EL 6625-2660-35-TB-13

Figure 13. Delay generator, bottom view (model 1781A).

44. Preset. a. Performance Check.

(1) Connect test oscillator (A5) output to TI INPUT connector, using cable (B6).

(2) Connect dc voltmeter (A12) between pin 3 of V13 (Fig. 12) and ground.

(3) Turn TI TRIGGER SLOPE switch to + (positive) and TRIGGER source switch to EXT AC.

(4) Adjust test oscillator frequency to 1 kHz and output for a 2-mm deflection on oscilloscope (A6).

(5) Turn SWEEP MODE control to FREE RUN; then back toward PRESET until sweep just stops. Record dc voltmeter indication.

(6) Turn SWEEP MODE control to preset. Dc voltmeter will indicate 1.5 volts more than voltage recorded in (5) above. If not, perform *b* below.

b. Adjustments. Adjust R60 (Fig. 13) for 1.5 volts dc more positive than indication recorded in (5) above.

45. Sweep Length. a. Performance Check.

(1) Connect test oscillator (A5) output to oscilloscope (A6) vertical INPUT connector, using cable (B6).

(2) Turn TI TRIGGER SOURCE switch to INT.

(3) Adjust oscillator for 600 kHz and output for 5 cm of deflection on oscilloscope crt.

(4) Adjust oscilloscope controls to position sweep horizontally so that end of sweep may be viewed.

(5) Adjust TI TRIGGER LEVEL control for shortest possible sweep. Sweep length observed on oscilloscope crt will be 10.2 cm. If not, perform *b* below.

b. Adjustments. Adjust R53 (Fig. 13) for sweep display length of 10.2 cm. (R)

46. Sweep Calibration. a. Performance Check.

(1) Connect marker generator (A4) MARKER OUTPUT connector to oscilloscope (A6) vertical INPUT connector, using cable (B6).

(2) Position TI controls as listed in (a) through (c) below:

(a) TRIGGER SOURCE switch to EXT AC.

(b) DELAY FUNCTION switch to TRIGGER MAIN SWEEP.

(c) DELAY LENGTH control to 10.

(3) Position oscilloscope controls as listed in (a) through (d) below:

(a) SWEEP MODE control to PRESET.

(b) TRIGGER SLOPE control to + (positive).

(c) TRIGGER SOURCE switch to INT.

(d) SWEEP TIME switch to .2 μ SEC/CM.

(4) Set marker generator for 1- μ S markers.

(5) Turn TI DELAYING SWEEP TIME/CM switch to 2 MICRO-SECONDS and adjust TRIGGER LEVEL controls for a stable display.

(6) Adjust DELAY LENGTH to position brightened portion of trace under third marker (approx 1 cm).

(7) Turn SWEEP SELECTOR switch to MAIN SWEEP DELAYED and adjust DELAY LENGTH control to position leading edge of third marker at start of trace. Record DELAY LENGTH control indication.

(8) Adjust DELAY LENGTH control to position leading edge of 21st marker at start of trace (approx 10 cm) and record DELAY LENGTH control indication. The difference between this indication and indication recorded in (7) above will be 9 cm \pm 10 minor divisions.

(9) Turn TI SWEEP SELECTOR switch to DELAYING SWEEP.

(10) Repeat technique of (4) through (9) above, using settings listed in table 17. Differences between DELAY LENGTH indications will be as specified. If not, perform *b* below.

b. Adjustments

(1) Repeat *a*(4) through (7) above, using respective values and settings.

(2) Add 9.00 to value recorded in (1) above and adjust DELAY LENGTH control to this value.

(3) Adjust appropriate adjustment listed in table 17 until leading edge of respective marker is aligned at start of trace.

47. High-Frequency Compensation. a. Performance Check.

(1) Turn oscilloscope (A6) SWEEP TIME switch to .2 mSEC/CM.

(2) Position TI controls as listed in (a) through (f) below:

(a) DELAYING SWEEP TIME/CM switch to .2 MILLISECONDS.

(b) SWEEP MODE switch to FREE RUN.

(c) TRIGGER SOURCE switch to EXT.

(d) SWEEP SELECTOR switch to MAIN SWEEP DELAYED.

(e) DELAY FUNCTION switch to TRIGGER MAIN SWEEP.

(f) DELAY LENGTH control greater than 1 cm.

(3) Connect standard probe (B 10) to oscilloscope vertical INPUT connector.

(4) Connect standard probe tip to TI pin 8 of V14 (Fig. 12). Bottom of sawtooth waveform observed on oscilloscope, crt will be flat. If not, perform *b* below.

b. Adjustments. Adjust C21 (Fig. 12) until bottom of sawtooth waveform is flat.

Table 17. Sweep Calibration

Oscilloscope SWEEP TIME switch position	TI TIME/CM switch position	Marker generator output setting	Check markers	Differences between DELAY LENGTH control Indication 9 cm \pm minor divisions	Adjustments (fig 13)
.2 μ sec	2 MICROSECONDS	1 μ sec	3 21	10	-----
.5 μ sec	5 MICROSECONDS	5 μ sec	2 11	10	C36(R)
1 μ sec	10 MICROSECONDS	10 μ sec	2 11	10	-----
2 μ sec	20 MICROSECONDS	10 μ sec	3 21	10	-----
5 μ sec	50 MICROSECONDS	50 μ sec	2 11	10	R92(R)
10 μ sec	.1 MILLISECONDS	.1 msec	2 11	10	-----
20 μ sec	.2 MILLISECONDS	.1 msec	3 21	10	-----
50 μ sec	.5 MILLISECONDS	.5 msec	2 11	10	R91(R)
.1 msec	1 MILLISECONDS	1 msec	2 11	10	-----
.2 msec	2 MILLISECONDS	1 msec	3 21	10	-----
.5 msec	5 MILLISECONDS	5 msec	2 11	10	R90(R)
1 msec	10 MILLISECONDS	10 msec	2 11	10	-----
2 msec	20 MILLISECONDS	10 msec	3 21	10	-----
5 msec	50 MILLISECONDS	50 msec	2 11	10	-----
10 msec	.1 SECONDS	.1 sec	2 11	10	R89(R)
20 msec	.2 SECONDS	.1 sec	3 21	30	-----
50 msec	.5 SECONDS	.5 sec	2 11	30	-----
.1 sec	1 SECONDS	1 sec	2 11	30	-----

48. Delay Length and Sweep. a. Performance Check.

(1) Turn oscilloscope (A6) SWEEP TIME switch to 10 μ SEC/CM.

(2) Position TI controls as listed in (a) through (d) below:

(a) DELAYING SWEEP TIME/CM switch to 1 MILLISECONDS.

(b) SWEEP MODE switch to PRESET.

(c) TRIGGER LEVEL switch to +(positive).

(d) TRIGGER SOURCE switch to INT.

(3) Connect marker generator (A4) MARKER OUTPUT connector to oscilloscope vertical INPUT connector, using cable (B6).

(4) Set marker generator for 1-mS markers.

(5) Turn TI DELAY LENGTH control to 1 CM. Oscilloscope crt will display waveform showing start of second marker at beginning of sweep. If not, perform b(1) below.

(6) Turn DELAY LENGTH CONTROL to 9 CM. Oscilloscope crt will display waveform showing start of tenth marker at beginning of sweep. If not, perform b(2) below.

(7) Turn TI DELAYING SWEEP TIME/CM switch to 50 MICROSECONDS.

(8) Set marker generator for 50 μ S markers.

(9) Adjust TI DELAY LENGTH control to position leading edge of second marker at beginning of oscilloscope trace (approx 1 cm).

(10) Increase DELAY LENGTH control indication by 9 cm. Observe that oscilloscope waveform displays leading edge of 11th marker at beginning of trace. If not, perform b(3) below.

(11) Turn TI DELAYING SWEEP TIME/CM switch to 5 MICROSECONDS.

(12) Set marker generator for 5 μ S markers.

(13) Repeat (9) and (10) above and perform b(4) below if desired condition is not obtained.

b. Adjustments.

(1) Adjust R63 (Fig. 13) to position second marker at beginning of sweep. (R)

(2) Adjust R67 (Fig. 13) to position tenth marker at beginning of sweep. (R)

NOTE

Adjustments R63 and R67 interact. Repeat (1) and (2) above as necessary.

(3) Adjust R92 (Fig. 13) to position leading edge of 11th marker at beginning of trace.

(4) Adjust C36 (Fig. 13) to position leading edge of 11th marker at beginning of trace.

NOTE

If adjustments (3) or (4) above are performed, repeat paragraph 46. Refer to paragraph 63 for final procedure.

SECTION VIII

CALIBRATION PROCEDURE FOR DELAY

GENERATOR, MODEL 1781B SG-988/U

49. Preliminary Procedure.

NOTE

Personnel should familiarize themselves with the entire bulletin prior to performing calibration.

- Remove bottom and side covers from oscilloscope (A6).
- Insert TI and vertical plug-in (A9) into oscilloscope.
- Connect oscilloscope to 115 Vac power source.
- Energize equipment and allow sufficient time for equipment to warmup and stabilize.

WARNING

HIGH VOLTAGE is used during the performance of this procedure. DEATH ON CONTACT may result if personnel fail to observe safety precautions.

NOTE

When the TI is not within tolerance, perform the specified adjustment and continue the performance check. When the TI is not within tolerance and no adjustment is specified, the deficiency must be corrected before continuing with the procedure.

50. Preset. a. Performance Check.

- Position TI controls as listed in (a) and (f).
 - DELAYING SWEEP TIME switch to 1 mSEC/CM.
 - SWEEP MODE switch to PRESET.
 - TRIGGER LEVEL control fully clockwise.
 - SWEEP SELECTOR control to DELAYING.
 - DELAY FUNCTION switch to TRIGGER.
 - SWEEP MODE switch to INT.

(2) Turn oscilloscope SWEEP MODE control to PRESET and SWEEP TIME control to .1 μ SEC/CM.

(3) Connect dc voltmeter (A12) between CR2 TEST POINT (Fig. 14) and ground.

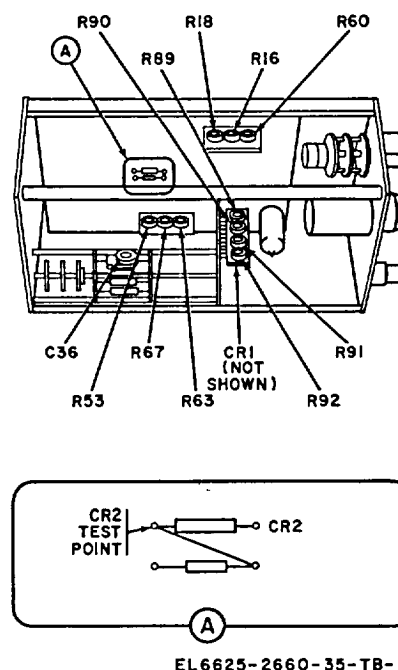

EL 6625-2660-35-TB-14

Figure 14. Delay generator, interior view (model 1781B).

(4) Turn R60 (Fig. 14) fully counterclockwise and then slowly clockwise while observing dc voltmeter indication. When dc voltmeter indication changes suddenly, record maximum indication before sudden change.

(5) Turn R60 fully counterclockwise and then slowly clockwise again until dc voltmeter indicates 2.5 volts less negative than voltage recorded in (4) above.

d. Adjustments. No further adjustments can be made.

51. Trigger Sensitivity and Symmetry. a. Performance Check.

(1) Turn TI TRIGGER SLOPE switch to (negative) and TRIGGER LEVEL control to 0 (zero).

(2) Position oscilloscope (A6) controls as listed in (a) through (c) below:

(a) SENSITIVITY switch to .05.

(b) Signal input switch to AC.

(c) HORIZONTAL DISPLAY switch to

X1.

(3) Connect test oscillator (A5) to oscilloscope vertical INPUT connector using cable (B6).

(4) Adjust test oscillator for 400 Hz and output for a 140 mV pp indication on oscilloscope crt.

(5) Disconnect cable (B6) from oscilloscope vertical INPUT and connect to TI EXT. INPUT connector. Turn TI TRIGGER SOURCE switch to AC.

(6) Connect standard probe (B10) to oscilloscope vertical INPUT connection.

(7) Connect standard probe tip to case of CR1 (Fig. 14).

(8) Obtain a stable display as shown in figure 15 (A), using TI TRIGGER LEVEL control. If not, perform *b* below.

(9) Disconnect standard probe from oscilloscope vertical INPUT connector.

(10) Repeat (3) above.

(11) Adjust test oscillator output for 200 mV pp indication on oscilloscope crt.

(12) Repeat (5) through (7) above.

(13) Ground the junction of R6 and R9 (fig. 16), using lead with two adapters (B9 and B2). Oscilloscope will display a symmetrical tunnel diode waveform as shown in figure 15 (B). If not, perform *b* below.

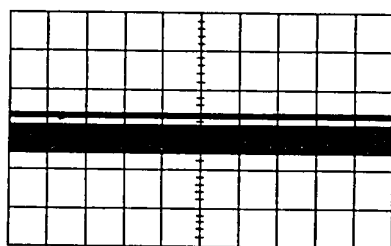

(A)

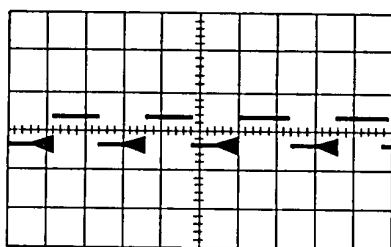

(B)

EL6625-2660-35-TB-15

Figure 15. Delay generator, trigger waveforms (Model 1781B).

(14) Remove lead and two adapters connected in (13) above.

(15) Turn TI TRIGGER SLOPE switch to + (positive). Waveform displayed on oscilloscope crt will remain symmetrical.

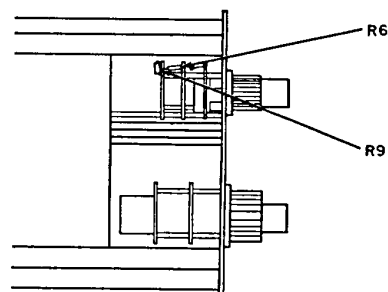

EL6625-2660-35-TB-16

Figure 16. Delay generator, top front view (Model 1781B).

b. Adjustments.

(1) Turn R18 (Fig. 14) fully clockwise and center R16 (Fig. 14). (R)

(2) Repeat a(3) through (7) above.

(3) Adjust TRIGGER LEVEL control to obtain display shown in figure 15 (A).

(4) Using TRIGGER LEVEL control to maintain display, adjust R18 to obtain a stable square wave as shown in figure 15 (B).

(5) Repeat a(9) through (12) above.

(6) Ground the junction of R6 and R9 (fig. 16), using lead with two adapters (B9 and B2).

(7) Adjust R16 (Fig. 14) for a symmetrical tunnel diode waveform as shown in figure 15 (B).

(8) Remove ground connected in (6) above.

52. Sweep Length. a. Performance Check.

(1) Connect test oscillator (A5) output to oscilloscope (A6) vertical INPUT connector, using cable (B6).

(2) Turn TI TRIGGER SOURCE switch to INT.

(3) Adjust oscillator for 600 kHz and output for a 5-cm vertical deflection on oscilloscope crt.

(4) Adjust oscilloscope controls to position trace horizontally so that end of trace may be viewed.

(5) Adjust TI TRIGGER LEVEL control for shortest possible sweep. Sweep length observed on oscilloscope crt will be 10.2 cm. If not, perform *b* below.

b. Adjustments. Adjust R53 (Fig. 14) for sweep display length of 10.2 cm.

53. Sweep Calibration. a. Performance Check.

(1) Connect marker generator (A4) MARKER OUTPUT connector to oscilloscope (A6) vertical INPUT connector, using cable (B6).

(2) Turn TI TRIGGER LEVEL control to 0 (zero).

(3) Position oscilloscope controls as listed in (a) through (c) below:

- (a) SENSITIVITY switch to 2 VOLTS/ CM.
- (b) TRIGGER SLOPE control to +

(positive).

- (c) TRIGGER SOURCE switch to INT.

(4) Set marker generator for 1 μS markers.

(5) Turn TI DELAYING SWEEP TIME switch to 2 μSEC/CM and adjust TRIGGER LEVEL controls for a stable display.

(6) Adjust DELAY LENGTH control to position brightened portion of trace under third marker (approx 1 cm).

(7) Turn SWEEP SELECTOR switch to MAIN

DELAYED and adjust DELAY LENGTH control to position leading edge of third marker at start of trace. Record DELAY LENGTH control indication.

(8) Adjust DELAY LENGTH control to position leading edge of 21st marker at start of trace (approx 10 cm) and record DELAY LENGTH control indication. The difference between this indication and indication recorded in (7) above will be 9 cm ±10 minor divisions.

(9) Turn TI SWEEP SELECTOR switch to DELAYING.

(10) Repeat technique of (4) through (9) above, using settings listed in table 18. Differences between DELAY LENGTH indications will be as specified. If not, perform *b* below.

Table 18. Sweep Calibration Check

Oscilloscope SWEEP TIME switch position	TI DELAYING SWEEP TIME switch	Marker generator output setting	Check markers	Differences between DELAY LENGTH control Indication 9 cm ± minor divisions	Adjustments (fig 14)
.5 μsec	5 μSEC/CM	5 μsec	2 11	10	C36(R)
1 μsec	10 μSEC/CM	10 μsec	2 11	10	-----
2 μsec	20 μSEC/CM	10 μsec	3 21	10	-----
5 μsec	50 μSEC/CM	50 μsec	2 11	10	R92(R)
10 μsec	.1 MSEC/CM	.1 msec	2 11	10	-----
20 μsec	.2 MSEC/CM	.1 msec	3 21	10	-----
50 μsec	.5 MSEC/CM	.5 msec	2 11	10	R91(R)
.1 msec	1 MSEC/CM	1 msec	2 11	10	-----
.2 msec	2 MSEC/CM	1 msec	3 21	10	-----
.5 msec	5 MSEC/CM	5 msec	2 11	10	R90(R)
1 msec	10 MSEC/CM	10 msec	2 11	10	-----
2 msec	20 MSEC/CM	10 msec	3 21	10	-----
5 msec	50 MSEC/CM	50 msec	2 11	10	-----
10 msec	.1 SEC/CM	.1 sec	2 11	10	R89(R)
20 msec	.2 SEC/CM	.1 sec	3 21	30	-----
50 msec	.5 SEC/CM	.5 sec	2 11	30	-----
.1 sec	1 SEC/CM	1 sec	2 11	30	-----

b. Adjustments.

(1) Repeat *a*(4) through (7) above, using respective values and settings.

(2) Add 9.00 to value recorded in (1) above and adjust DELAY LENGTH control to this value.

(3) Adjust appropriate adjustments listed in table 18 until leading edge of respective marker is aligned at start of trace.

54. Delay Length and Sweep. a. Performance Check.

(1) Turn oscilloscope (A6) SWEEP TIME switch to 10 μSEC/CM.

(2) Turn TI SWEEP SELECTOR switch to MAIN DELAYED and DELAYING SWEEP TIME switch to 1 mSEC/CM.

(3) Adjust marker generator (A4) for 1 mS markers.

(4) Turn TI DELAY LENGTH control to 1 CM. Oscilloscope crt will display waveform showing start of second marker at beginning of sweep. If not, perform *b*(1) below.

(5) Turn DELAY LENGTH control to 9.00 CM. Oscilloscope crt will display waveform showing start of tenth

marker at beginning of sweep. If not, perform *b*(2) below.

(6) Turn TI DELAYING SWEEP TIME switch to 50μSEC/CM.

(7) Set marker generator for 50 μS markers.

(8) Adjust TI DELAY LENGTH control to position leading edge of second marker at beginning of oscilloscope trace (approx 1 cm).

(9) Increase DELAY LENGTH control by 9 cm. Observe that oscilloscope waveform displays leading edge of 11th marker at beginning of trace. If not, perform *b*(3) below.

(10) Turn TI DELAYING SWEEP TIME switch to 5 μSEC/CM.

(11) Set marker generator for 5 μS markers.

(12) Repeat technique of (8) and (9) above, except, if desired condition is not obtained, perform *b*(4) below.

b. Adjustments.

(1) Adjust R67 (Fig. 14) to position start of second marker at beginning of sweep. (R)

(2) Adjust R63 (Fig. 14) to position start of tenth marker at beginning of sweep. (R)

NOTE

Adjustments R63 and R67 interact. Repeat (1) and (2) above as necessary.

(3) Adjust R92 (Fig. 14) to position leading edge of 11th marker at beginning of trace. (R)

(4) Adjust C36 (Fig. 14) to position leading edge of 11th marker at beginning of trace. (R)

NOTE

If adjustments (3) or (4) above are performed, repeat paragraph 53a. Refer to paragraph 63 for final procedure.

SECTION IX

**MAINTENANCE CALIBRATION PROCEDURE FOR OSCILLOSCOPE
H12-175A AND HO-175A**

55. Equipment and Accessories Required.

a. Equipment required for calibration performance tests is listed in table 19 and is referenced within the text by common name and item identification number prefixed C.

b. Accessories required for calibration performance tests are listed in table 20 and are referenced within its text by common name and item identification number prefixed D.

WARNING

Voltages hazardous to life are present inside the TI. Use extreme care when

making connection or taking measurements inside the TI cabinets.

NOTE

Minimum use specifications are the principal parameters required for the performance of the calibration, and are included to assist in the selection of alternate equipment. Satisfactory performance of alternate items shall be verified prior to use. All applicable equipment must bear evidence of current calibration.

Table 19. Equipment Required for Maintenance Calibration

<i>Item number</i>	<i>Common name</i>	<i>Minimum use specifications</i>	<i>Calibration equipment*</i>
C1	Marker generator	Range: 10 ns - 5 sec Accuracy: $\pm 1\%$	AN/USM-308 (H-P 8690B)
C2	Horizontal plug-in**	Must be compatible with TI	H-P models 1780A, 1781B, 1782A, 1783A
C3	Vertical plug-in**	Must be compatible with TI.	H-P models 1750B or 1752A
C4	Autotransformer	Range: 105-125 V ac Accuracy: $\pm 1\%$	TF-5101U (G-R W10MT3A)
C5	Meter calibrator	Range: 0.3535-17.67 V rms Accuracy: $\pm 0.25\%$	TS-2734/U (Fluke 760A)
C6	Signal generator	Range: 50 kHz-1MHz; 0.03-3 V rms Accuracy: $\pm 1\%$	AN/USM-264 (H-P 652A)
C7	Signal generator	Range: 0-40V pp, 4-40 kHz Accuracy: $\pm 1\%$	AN/USM-256 (Fairchild 791)
C8	Multimeter	Range: 26 V dc Accuracy: $\pm 1\%$	ME-333/U (J-Omega 217A)
C9	Vertical response tester plug-in	Provide vertical voltage	PL-12481U (H-P, model 10405A)

*The calibration equipment utilized in this procedure was selected from those known to be available in AN/TSM-55(V) 2 and AN/TSM-55(V) 5, and the listing by make or model number carries no implication of preference, recommendation, or approval by the Department of Defense for use by other agencies. It is recognized that equivalent equipment produced by other manufacturers may be capable of equally satisfactory performance in the procedure.

**Additional equipment required and must be calibrated and compatible with TI.

Table 20. Accessories Required for Maintenance Calibration

<i>Item number</i>	<i>Common name</i>	<i>Description</i>
D1	Adapter (2 required)	Single banana jack-to-alligator clip (black)
D2	Adapter	BNC T type, two jacks, one plug
D3	Cable (2 required)	30-in., RG-58() /U; BNC plug terminations
D4	Cable	36-in., RG-58() /U; BNC plug and double banana plug terminations
D5	Cable (2 required)	36-in., RG-58/U; BNC plug and alligator clips
D6	Lead	24-in., No. 18 AWG single banana plug terminations (black)
D7	Termination	50-ohm feed-through, BNC plug-to-BNC jack
D8	Adapter (2 required)	Binding posts-to-BNC plug
D9	Test probe	10X
D10	Test adapter	UG-1852/U

56. Preliminary Procedure. a. Energize equipment and allow sufficient time for equipment to warmup and stabilize.

b. Adjust autotransformer (C4) output voltage control to minimum.

c. Connect TI power cord to autotransformer.

d. Adjust autotransformer output voltage control for a meter indication of 115 volts ac.

e. Install vertical amplifier plug-in (C3) into vertical compartment of TI.

f. Install time base unit plug-in (C2) into horizontal compartment of TI.

g. Position TI controls as follows:

(1) HORIZONTAL DISPLAY switch to 1 VOLT/CM AC.

(2) EXTERNAL VERNIER control to CAL.

(3) TRIGGER SOURCE switch to INT.

(4) TRIGGER SLOPE switch to + (positive).

(5) TRIGGER LEVEL control to 0.

(6) SWEEP MODE control to PRESET.

(7) SWEEP TIME switch to 1 MSEC/CM.

(8) SWEEP VERNIER control to CAL.

(9) INTENSITY MODULATION switch (rear)

to INT.

h. Set TI POWER switch to on (up) and allow 15 minutes warmup.

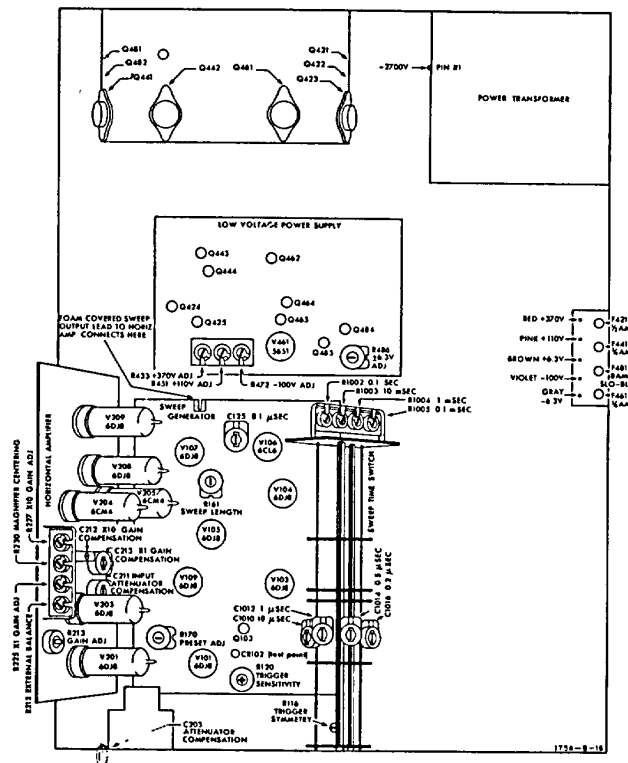

EL6625-2660-35-TB-17

NOTE

When the TI is not within tolerance, perform the specified adjustment and continue the performance check. When the TI is not within tolerance and no adjustment is specified, the deficiency must be corrected before continuing with the procedure.

57. Horizontal Amplifier Gain. a. Performance Check.

(1) Connect meter calibrator (C5) to TI HORIZ INPUT connector with cable assembly (D4).

(2) Set TI HORIZONTAL DISPLAY switch to 1 VOLT/CM AC.

(3) Set meter calibrator decade dials to 00.5350.

(4) Adjust meter calibrator output controls for 400 Hz and TI display of 10 cm horizontal deflection.

(5) Meter calibrator indicates between -5% and +5%.

(6) Set meter calibrator output controls to 0.

(7) Set TI HORIZONTAL DISPLAY switch to 0.1 VOLT/CM AC.

(8) Set meter calibrator decade dials to 000.3535.

(9) Repeat steps (4) and (5).

(10) Turn TI EXTERNAL VERNIER control fully counterclockwise.

Figure 17. Test instrument, bottom view

(11) TI displays horizontal deflection of 1 cm.

(12) Set TI EXTERNAL VERNIER control to CAL.

(13) Disconnect equipment.

(14) Connect signal generator (C6), 0 Ω connector to TI HORIZ INPUT connector with cable assembly (D3) and termination (D7).

(15) Adjust signal generator (C6) controls for 50 kHz and TI display of 10 cm horizontal trace.

(16) Increase signal generator frequency controls for TI display of 7 cm horizontal trace.

(17) Signal generator indicates greater than 500 kHz.

(18) Disconnect equipment.

b. Adjustments.

(1) Set TI HORIZONTAL DISPLAY switch to X1.

(2) Disconnect TI foam-covered wire (Fig. 17) from sweep generator printed circuit board.

(3) Connect meter calibrator between TI foam-covered wire and chassis ground with test lead (D5). Vac.

(4) Adjust meter calibrator controls for an output of 17.675 Vac.

- (5) Adjust X1 GAIN ADJ, R225 (Fig. 17) for TI horizontal display of 5.5 cm. (R)
- (6) Adjust meter calibrator controls for output of 1.76575 Vac.
- (7) Set TI HORIZONTAL DISPLAY switch to X10.
- (8) Adjust X10 GAIN ADJ, R227 (Fig. 17) for TI horizontal display of 5.5 cm. (R)
- (9) Disconnect equipment.
- (10) Adjust TI SWEEP MODE control for CRT display of dot.
- (11) Adjust TI HORIZONTAL POSITION control to center dot on CRT.
- (12) Adjust MAGNIFIER CENTERING, R230 (Fig. 17) for display of no horizontal shift of dot as TI HORIZONTAL DISPLAY is set from X1 to X10. (R)
- (13) Set TI HORIZONTAL DISPLAY switch to 0.1 VOLT/CM DC.
- (14) Adjust TI HORIZONTAL POSITION control to center dot on CRT.
- (15) Adjust EXTERNAL BALANCE, R212 (Fig. 17) for display of no horizontal shift of dot as TI EXTERNAL VERNIER is turned from limit to limit. (R)

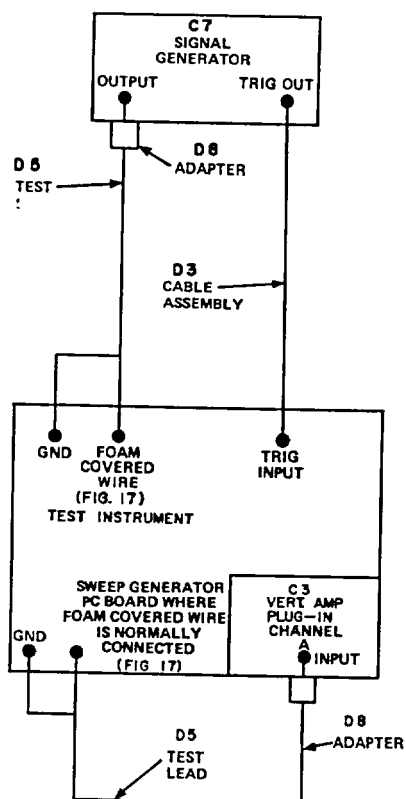

EL6625-2660-35-TB-18

Figure 18. Horizontal amplifier setup.

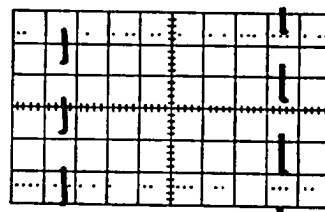

NOTE:

IT MAY BE NECESSARY TO SLIGHTLY ADJUST TI PRESET AND R170 (F 17) FOR OSCILLOSCOPE DISPLAY.

EL6625-2660-35-TB-19

Figure 19. Frequency compensation.

- (16) Connect meter calibrator to TI HORIZ INPUT with cable assembly (D4)
- (17) Set TI EXTERNAL VERNIER control to CAL.
- (18) Adjust meter calibrator controls for output of 0.3535 Vac.
- (19) Adjust GAIN ADJ, R213 (Fig. 17) for 10 cm horizontal display. (R)
- (20) Disconnect equipment.
- (21) Connect equipment as shown in figure 18.
- (22) Position vertical amplifier plug-in unit CHANNEL A controls as follows:
 - (a) SENSITIVITY V/CM switch to 10.
 - (b) VERNIER control to Cal.
 - (c) AC/DC switch to AC.
- (23) Position TI controls as follows:
 - (a) HORIZONTAL DISPLAY switch to X1.
 - (b) TRIGGER SOURCE switch to EXT AC.
 - (c) SWEEP MODE control to PRESET.
 - (d) SWEEP TIME switch to 0.1 mSEC/CM.
- (24) Adjust signal generator (C7) controls for 4 kHz and maximum output.
- (25) Adjust TI TRIGGER LEVEL and HORIZONTAL POSITION controls for stable centered CRT display (Fig. 19).
- (26) Adjust X1 GAIN COMPENSATION, C213 (Fig. 17) to a point between mid-range and lowest capacitance. (R)
- (27) Adjust INPUT ATTENUATOR COMPENSATION, C211 (Fig. 17) for display of best square wave. (R)
- (28) Set TI HORIZONTAL DISPLAY switch to X10.
- (29) Adjust signal generator controls for 4 kHz and TI display of 8 cm pp.
- (30) Adjust INPUT ATTENUATOR COM-

PENSATION, C211 (Fig. 17) for display of optimum square wave with TI HORIZONTAL DISPLAY switch settings of X1 and X10. (R)

(31) Set TI HORIZONTAL DISPLAY switch to X1 and SWEEP TIME switch to 10 μ SEC/CM.

(32) Adjust signal generator controls for 40 kHz and maximum output.

(33) Adjust X1 GAIN COMPENSATION, C213 (Fig. 17) for display of optimum square wave. (R)

(34) Set TI HORIZONTAL DISPLAY switch to X10.

(35) Adjust signal generator controls for 40 kHz and TI display of 8 cm pp.

(36) Adjust X10 GAIN COMPENSATION, C212 (Fig. 17) for display of optimum square wave. (R)

(37) Disconnect adapter (D8) and test lead (D5) from signal generator output connector.

(38) Connect signal generator output connector to TI HORIZ INPUT with cable assembly (D3).

(39) Set TI HORIZONTAL DISPLAY switch to 1 VOLT/CM DC.

(40) Adjust signal generator for 4 kHz and TI display of 8 cm horizontal deflection.

(41) Adjust ATTENUATOR COMPENSATION, C203 (Fig. 17) for display of round dot (Fig. 20).

(42) Connect TI foam-covered wire to TI sweep generator (Fig. 17).

(43) Repeat performance check.

58. Sweep Generator. a. Performance Check.

(1) Set TI HORIZONTAL DISPLAY switch to X1.

(2) Connect signal generator (C6) 50 connector to vertical amplifier plug-in unit CHANNEL A INPUT connector with cable assembly (D3) and termination (D7).

(3) Set VERTICAL plug-in unit CHANNEL A SENSITIVITY V/CM switch to 1.

(4) Adjust signal generator controls for 1 kHz and 3.0 volts rms on output meter.

(5) TI displays stable synchronized sine wave.

(6) Turn TI TRIGGER LEVEL control clockwise and counterclockwise. CRT displays sweep start adjustable to any point on positive slop of signal.

(7) Set TI TRIGGER SLOPE switch to (negative).

(8) Turn TI TRIGGER LEVEL control clockwise and counterclockwise. CRT displays sweep start adjustable to any point on negative slop of signal.

(9) Set TI TRIGGER SLOPE switch to + (positive) and SWEEP TIME switch to 1 μ SEC/CM.

(10) Set vertical amplifier plug-in unit SENSITIVITY V/CM switch to .5.

(11) Adjust signal generator controls for 1 MHz and TI vertical display of 1 cm pp.

(12) Adjust TI TRIGGER LEVEL for stable synchronized display.

(13) Reduce signal generator amplitude for TI display of minimum triggered amplitude.

(14) TI displays amplitude of .2 cm or less.

(15) Set TI TRIGGER SOURCE switch to EXT DC.

(16) TI display is .5 cm or less.

(17) Disconnect equipment.

(18) Connect time mark generator (C1) to vertical amplifier plug-in unit CHANNEL A INPUT connector with cable assembly (D3).

(19) Set TI TRIGGER SOURCE switch to INT.

(20) Adjust time mark generator for outputs listed in table 21. At each setting perform the following:

(a) Set TI SWEEP TIME switch to settings listed.

(b) Adjust TI HORIZONTAL POSITION control for display of marker listed aligned with first cm line.

(c) Marker at 9th cm line is within 0.3 cm.

(21) Set TI SWEEP TIME switch to 0.1 mSEC/CM and HORIZONTAL DISPLAY switch to X10.

(22) Set marker generator output for .1 mS.

(23) Adjust TI HORIZONTAL POSITION control for display of first marker at left graticule line.

(24) TI displays second marker within 0.5 cm of 10th cm line.

(25) Disconnect equipment.

b. Adjustments.

(1) Set TI HORIZONTAL DISPLAY switch to X1 and SWEEP TIME switch to 10 μ SEC/CM.

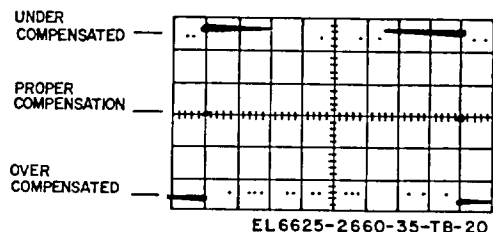

Figure 20. Attenuator compensation waveform.

Table 21. Sweep Time

Marker generator output	SWEEP TIME switch setting	TI Marker at 1st cm line	TI Marker at 9th cm line
.1 μ S	.1 μ SEC/CM	2nd	10th
.1 μ S	.2 μ SEC/CM	3rd	19th
.5 μ S	.5 μ SEC/CM	2nd	10th
1 μ S	1 μ SEC/CM	2nd	10th
1 μ S	2 μ SEC/CM	3rd	19th
5 μ S	5 μ SEC/CM	2nd	10th
10 μ S	10 μ SEC/CM	2nd	10th
10 μ S	20 μ SEC/CM	3rd	19th
50 μ S	50 μ SEC/CM	2nd	10th
.1 mS	.1 mSEC/CM	2nd	10th
.1 mS	.2 mSEC/CM	3rd	19th
.5 mS	.5 mSEC/CM	2nd	10th
1 mS	1 mSEC/CM	2nd	10th
1 mS	2 mSEC/CM	3rd	19th
5 mS	5 mSEC/CM	2nd	10th
10 mS	10 mSEC/CM	2nd	10th
10 mS	20 mSEC/CM	3rd	19th
50 mS	50 mSEC/CM	2nd	10th
.1 S	.1 SEC/CM	2nd	10th
.1 S	.2 SEC/CM	3rd	19th
.5 S	.5 SEC/CM	2nd	10th
1 S	1 SEC/CM	2nd	10th
1 S	2 SEC/CM	3rd	19th
5 S	5 SEC/CM	2nd	10th

(2) Connect multimeter (C8) between TI pin 3 of V109 (Fig. 17) and ground with test lead (D5).

(3) Adjust TI SWEEP MODE control for multimeter maximum negative indication.

(4) Record multimeter indication.

(5) Set TI SWEEP MODE control to PRESET.

(6) Adjust PRESET ADJ, R170 (Fig. 17) for multimeter indication 2.5 volts dc less negative than multimeter indication recorded in step (4). (R)

(7) Disconnect equipment.

(8) Position TI controls as follows:

(a) TRIGGER SLOPE switch to - (negative).

(b) TRIGGER SOURCE switch to EXT AC.

(c) SWEEP TIME switch to mSEC/CM.

(9) Connect signal generator 5; output connector to TI TRIG INPUT connector with cable assembly (D3) and termination (D7).

CAUTION

110 Vdc is present at CR102.

(10) Connect vertical amplifier plug-in unit CHANNEL A INPUT connector TI case of CR102 (Fig. 17) with test probe (D9).

(11) Adjust TRIGGER SYMMETRY, R116 (Fig. 17) to mid-range. (R)

(12) Adjust TRIGGER SENSITIVITY, R120 (Fig. 17) fully clockwise. (R)

(13) Adjust signal generator controls for 1 kHz and .05 volt ac.

(14) Set vertical plug-in unit CHANNEL A SENSITIVITY V/CM switch to .05.

(15) Adjust TI TRIGGER LEVEL control for display of free running trace (Fig. 21).

(16) Set TI SWEEP TIME switch to .5 mSEC/CM.

(17) Adjust TRIGGER SENSITIVITY, R120 (Fig. 17) counterclockwise for display of synchronized square wave (Fig. 21). (R)

NOTE

It may be necessary to adjust TI TRIGGER LEVEL control to maintain display.

(18) Adjust signal generator controls for 1 kHz and .03 volt ac.

(19) Adjust TRIGGER SENSITIVITY, R120 (Fig. 17) for unstable display. (R)

(20) Repeat steps (13) thru (19) until no further adjustment is required.

(21) Set TI TRIGGER SLOPE switch to + (positive).

(22) Ground TI TRIGGER SLOPE switch (green/orange wire) with test lead (D6) and two adapters (D1).

(23) Adjust TRIGGER SYMMETRY, R116 (Fig. 17) for display of symmetrical square wave. (R)

(24) Disconnect equipment.

(25) Position TI controls as follows:

(a) TRIGGER SOURCE switch to INT.

(b) TRIGGER LEVEL control to 0.

(c) TRIGGER SLOPE switch to + (positive).

- (d) SWEEP MODE control to PRESET.
- (e) SWEEP TIME switch to 1 mSEC/CM.
- (26) Connect time mark generator to vertical amplifier plug-in unit CHANNEL A INPUT connector with cable assembly (D3).
- (27) Adjust time mark generator for 1 mS markers.
- (28) Adjust vertical amplifier plug-in unit SENSITIVITY controls for TI display of 3 cm pp markers.
- (29) Adjust TI HORIZONTAL POSITION

- control for display of second marker aligned with first graticule line.
- (30) Adjust SWEEP LENGTH, R161 (Fig. 17) for display of sweep length to last graticule line. (R)
- (31) Adjust time mark generator for outputs listed in table 22. At each setting perform the following:
 - (a) Set TI SWEEP TIME switch to settings listed.
 - (b) Adjust TI HORIZONTAL POSITION control for display of marker listed aligned with first cm line.

Table 22. Sweep Time Adjustments

Marker generator output	SWEEP TIME switch setting	CRT Display marker at 1st cm line	TI	Adjustment (fig 17)	CRT Display marker at 9th cm line
.1 μS	.1 μSEC/CM	2nd		C125(R)	10th
.1 μS	.2 μSEC/CM	3rd		C1016(R)	19th
.5 μS	.5 μSEC/CM	2nd		C1014(R)	10th
1 μS	1 μSEC/CM	2nd		C1012(R)	10th
10 μS	10 μSEC/CM	2nd		C1010(R)	10th
.1 mS	.1 mSEC/CM	2nd		R1005(R)	10th
1 mS	1 mSEC/CM	2nd		R1004(R)	10th
10 mS	10 mSEC/CM	2nd		R1003(R)	10th
.1 S	.1 SEC/CM	2nd		R1002(R)	10th

- (c) Adjust TI adjustments listed for marker specified at 9th cm line.
- (32) Repeat performance check:

59. Vertical Amplifier Gain. a. Performance Check.

- (1) Set TI POWER switch to OFF (down).
- (2) Disconnect vertical amplifier plug-in unit.
- (3) Connect meter calibrator to TI J1 connector (vertical amplifier plug-in compartment) with test adapter (D10) and cable assembly (D4).
- (4) Position TI controls as follows:
 - (a) POWER switch to ON (up).
 - (b) HORIZONTAL DISPLAY switch to X1.
 - (c) SWEEP TIME switch to 1 mSEC/CM.

- (5) Set meter calibrator decade dials to 000.3535.
- (6) Adjust meter calibrator output controls and test adapter POSITION control for TI display of 5 cm pp sine waves.
- (7) Meter calibrator indicates between -5% and +5%.

- (8) Disconnect equipment.

b. Adjustments.

- (1) Adjust meter calibrator output controls for null indication on output meter.
- (2) Adjust GAIN R45 (Fig. 22) for display of 5 cm pp sine wave. (R)
- (3) Repeat performance check.

60. Vertical Amplifier Bandwidth. a. Performance Check.

NOTE
TI must be set up-right to normal operating position because of mercury pulser in vertical response tester.

- (1) Set TI power switch to OFF.
- (2) Install tester plug-in (C9) in vertical amplifier plug-in compartment.
- (3) Set TI POWER switch to ON (up).
- (4) Position TI controls as follows:
 - (a) SWEEP TIME switch to .1 μSEC/CM.
 - (b) TRIGGER SOURCE switch to INT.
 - (c) SWEEP MODE control to PRESET.
 - (d) HORIZONTAL DISPLAY switch to X10.
 - (e) TRIGGER SLOPE switch to + (positive).

- (5) Adjust tester plug-in controls for positive going 5 cm pulses.
- (6) Adjust TI HORIZONTAL POSITION control for TI display with start of trace at center vertical line.
- (7) TI displays risetime (10% to 90% points) of 0.007 psec or less.

b. Adjustments.

- (1) Position TI controls as follows:
 - (a) SWEEP TIME switch to 0.5 μSEC/CM.
 - (b) HORIZONTAL DISPLAY switch to X1.
- (2) Adjust TI TRIGGER LEVEL control for stable display.
- (3) Adjust MID FREQ RESPONSE, C22 (Fig. 22) for display of pulse with leading corner dropped 0.2 cm (Fig. 23). (R)

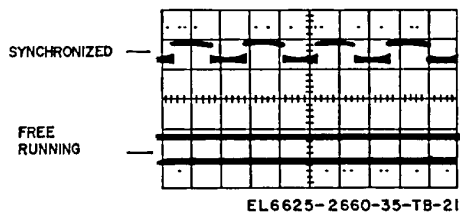

Figure 21. Trigger sensitivity.

- (4) Adjust LOW FREQ RESPONSE, C35 (Fig. 22) for display of optimum flat top pulse. (R)
- (5) Adjust MID FREQ RESPONSE, C22 (Fig. 22) for TI display of pulse as shown in figure 24. (R)
- (6) Set TI SWEEP TIME switch to 0.1 μ SEC/CM.

NOTE

TI adjustment L7 and L8 may be replaced by a variable capacitor in some units.

- (7) Adjust HIGH FREQ RESPONSE, L7 and L8 (Fig. 22) for display of optimum square corners (Fig. 25).
- (8) Repeat performance check.

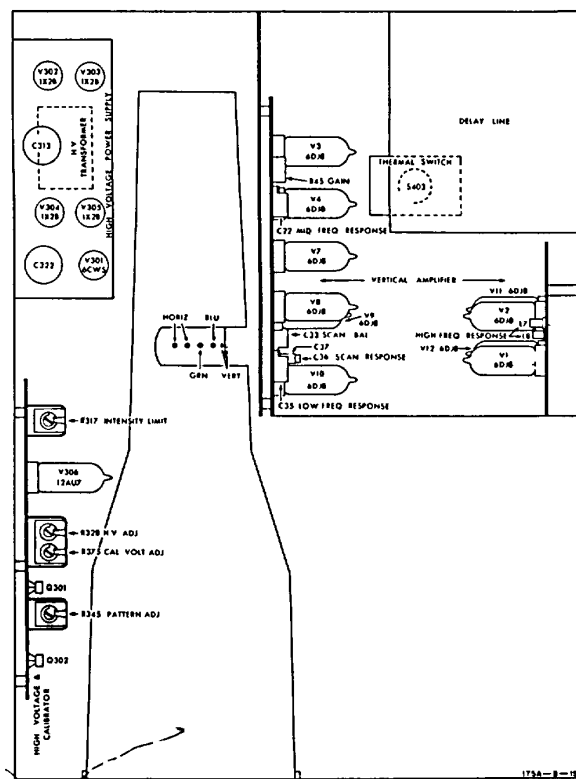

EL6625-2660-35-TB-22

Figure 22. Test instrument top view.

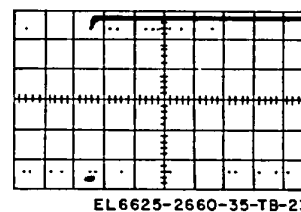

Figure 23. Midfrequency response preliminary adjustment.

- 61. Calibrator. a. Performance Check.**
 - (1) Set TI POWER switch to OFF (down).
 - (2) Remove plug-in (C9).
 - (3) Install vertical amplifier plug-in unit (C3) and set TI POWER switch to on (up).
 - (4) Position TI controls as follows:
 - (a) SWEEP TIME switch to 1 mSEC/CM.
 - (b) HORIZONTAL DISPLAY switch to X1.
 - (5) Set vertical amplifier plug-in unit CHANNEL A SENSITIVITY V/CM switch to 1.
 - (6) Connect meter calibrator to vertical amplifier plug-in unit CHANNEL A INPUT connector with cable assembly (D4).
 - (7) Adjust meter calibrator for 3.535 volts ac output.
 - (8) Adjust vertical amplifier plug-in unit CHANNEL A VERNIER control for TI display of 5 cm pp vertical deflection.
 - (9) Disconnect equipment.
 - (10) Connect TI CALIBRATOR 1 kHz 10 VOLTS connector to vertical amplifier plug-in unit CHANNEL A INPUT connector with cable assembly (B7).
 - (11) TI CRT displays between 4.95 to 5.05 cm pp of vertical deflection.
 - (12) Disconnect equipment.

b. Adjustments.

- (1) Adjust CAL VOLT ADJ, R375 (Fig. 22) for TI display of 5 cm vertical deflection. (R)
- (2) Repeat performance check.

62. Intensity Modulation. a. Performance Check.

- (1) Connect signal generator (C7) to vertical amplifier plug-in unit CHANNEL A INPUT connector and TI INTENSITY MODULATION connector (rear) with adapter (D2) and two cables (D3).

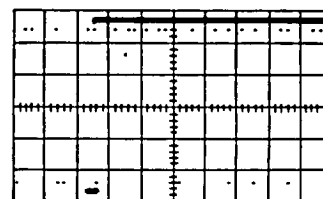

EL6625-2660-35-TB-24

Figure 24. Midfrequency response final adjustment.

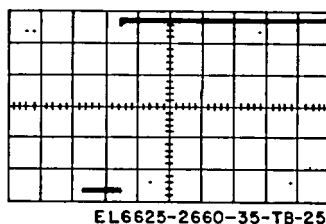

Figure 25. High frequency response.

(2) Set TI SWEEP TIME switch to 20 μ SEC/CM.

(3) Set vertical amplifier plug-in unit CHANNEL A controls as follows:

(a) SENSITIVITY VOLTS/CM switch to

10.

(b) POLARITY switch to + (positive).

(c) VERNIER control to CAL.

(4) Adjust signal generator (C7) controls for 10 kHz and TI display of 4 cm pp square wave.

(5) Set TI INTENSITY MODULATION switch to EXT.

(6) TI displays bottom of square wave intensified and top of square wave not intensified.

b. *Adjustments.* No adjustments can be made.

63. Final Procedure. a. De-energize and disconnect all equipment.

b. in accordance with TM 38-750, annotate and affix DA Label 80 (US Army Calibration System). When the TI cannot be adjusted within tolerance, annotate and affix red tag, DA Form 2417 (Unserviceable or Limited Use).

By Order of the Secretary of the Army:

Official:

FRED C. WEYAND
General, United States Army
Chief of Staff

PAUL T. SMITH
Major General, United States Army
The Adjutant General

Distribution:

To be distributed in accordance with DA Form 12-34A (qty rqr block No. 75), requirements for Calibration Procedures Publications.

TB 11-6625-2660-35

PIN : 012911-001