

TB 9-6625-086-35

Change 2

DEPARTMENT OF THE ARMY TECHNICAL BULLETIN

CALIBRATION PROCEDURE FOR POWER METER, HEWLETT-PACKARD, MODELS 431B AND 431C (AN/USM-260)

Headquarters, Department of the Army, Washington, DC
2 August 1985

TB 9-6625-086-35, 12 December 1975, is changed as follows:

Page 1, paragraph 2. In lines 4 and 5, change "TM 38-750" to read "750-25."

Paragraph 3. In lines 7 and 8, changes address to read "Commander, US Army TMDE Support Group, ATTN: AMXTM-LPP, Redstone Arsenal, AL 35898-5400."

Page 7, paragraph 12a(2) is superseded as follows:

(2) Set resistance decade (A7) to 10 k Ω . This 10 k Ω value can be decreased as necessary to obtain full-scale indication on TI.

Page 9, paragraph 15b is superseded as follows:

b. When all parameters are within tolerance, annotate and affix DA Label 80 (US Army Calibration Instrument). When the TI receives limited or special calibration, annotate and affix DA Label 163 (US Army Limited or Special Calibration). When the TI cannot be adjusted within tolerance, repair the TI in accordance with the maintenance manual. When repair is delayed for any reason or the TI cannot be repaired with local resources, annotate and affix DA Form 2417 (US Army Calibration System Rejected Instrument) and inform the owner/user accordingly in accordance with TB 750-25.

By Order of the Secretary of the Army:

JOHN A. WICKHAM, JR.
General, United States Army
Chief of Staff

Official:

DON J. DELANDRO
Brigadier General, United States Army
The Adjutant General

Distribution:

To be distributed in accordance with DA Form 12-34C, Block No. 319, requirements for calibration publications.

US GOVERNMENT PRINTING OFFICE: 1985 - - 544-007/20156 Region #4

PIN: 010318-002

TB 9-6625-086-35

Change 1

DEPARTMENT OF THE ARMY TECHNICAL BULLETIN

CALIBRATION PROCEDURE FOR POWER METER, HEWLETT-PACKARD MODELS 431B AND 431C (AN/USM-260)

Headquarters, Department of the Army, Washington, DC

29 August 1977

TB 9-6625-086-35, 12 December 1975, is changed as follows:

Page 5, paragraph 10a(3) is superseded as follows:

(3) Position the TI RANGE switch to the .01 MW position and adjust the zero controls for 0.00 V dc on the dc voltmeter.

Page 8, figure 4 is superseded as follows:

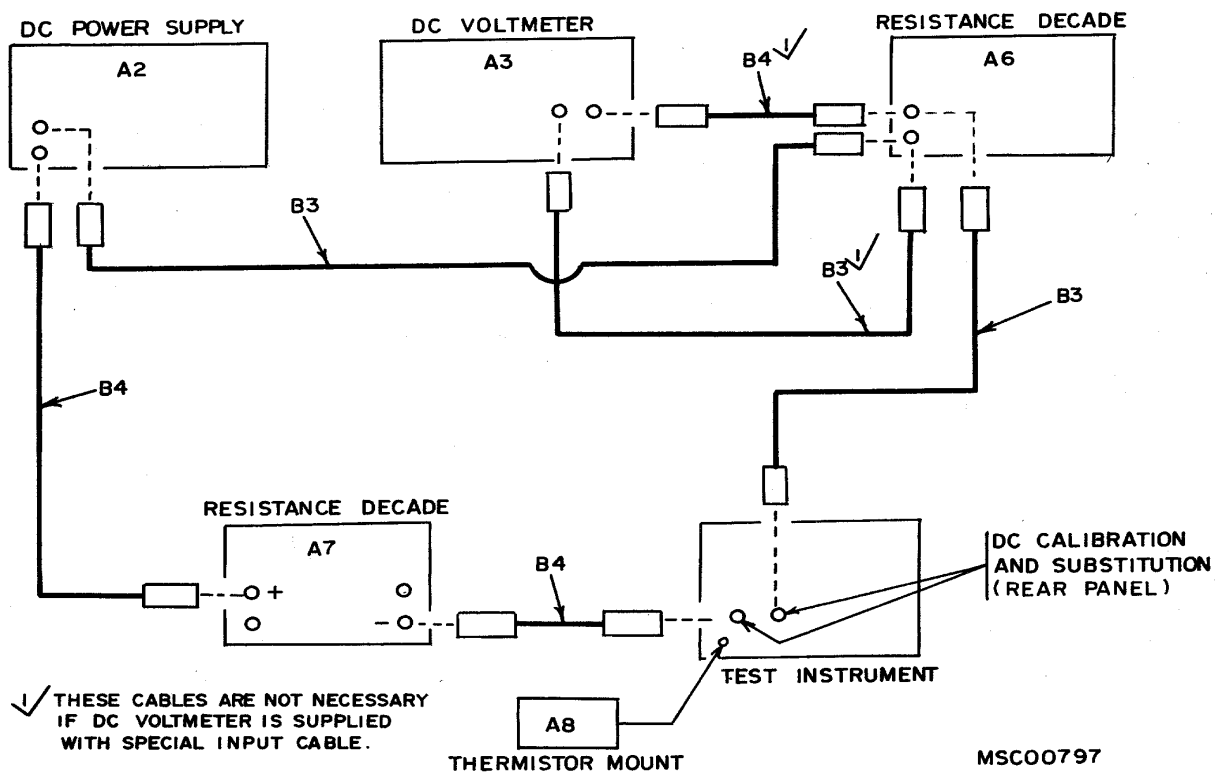

Figure 4. Range and tracking check without power meter calibrator.

By Order of the Secretary of the Army:

BERNARD W. ROGERS
General, United States Army
Chief of Staff

Official:

PAUL T. SMITH
Major General, United States Army
The Adjutant General

Distribution:

To be distributed in accordance with DA Form 12-34A, Requirements for Calibration Procedures.

U.S. GOVERNMENT PRINTING OFFICE: 1977-765010/180

PIN NO: 010318-001

TB 9-6625-086-35

DEPARTMENT OF THE ARMY TECHNICAL BULLETIN

CALIBRATION PROCEDURE FOR POWER METER, HEWLETT-PACKARD MODELS 431B AND 431C (AN/USM-260)

Headquarters, Department of the Army, Washington, DC
12 December 1975

◆ REPORTING OF ERRORS ◆

You can help improve this publication by calling attention to errors and by recommending improvements and stating your reasons for the recommendations. Your letter or DA Form 2028, Recommended Changes to Publications, should be mailed directly to Commander, U.S. Army Aviation and Missile Command, ATTN: AMSAM-TMD-EP, Redstone Arsenal, AL 35898-5000. FAX to DSN 788-2313 (commercial 256-842-2313). A reply will be furnished directly to you.

SECTION		Paragraph	Page
I.	IDENTIFICATION AND DESCRIPTION		
	Test instrument identification.....	1	2
	Calibration data card, DA Form 2416.....	2	2
	Calibration description.....	3	2
II.	EQUIPMENT REQUIREMENTS		
	Equipment required	4	2
	Accessories required.....	5	3
III.	PRELIMINARY OPERATIONS		
	Preliminary instructions	6	4
	Equipment Setup.....	7	4
IV.	CALIBRATION PROCESS		
	Coarse null.....	8	5
	Zero and vernier	9	7
	Range and tracking check with power meter calibrator.....	10	7
	Range and tracking without power meter calibrator.....	11	9
	Oscillator frequency.....	12	11
	Power supply	13	12
	Final procedure.....	14	13

**SECTION I
IDENTIFICATION AND DESCRIPTION**

1. Test Instrument Identification. This bulletin provides instructions for the calibration of Power Meter, Hewlett-Packard Models 431B and 431C (AN/USM-260). The manufacturer's instruction manual was used as the prime data source in compiling these instructions. The equipment being calibrated will be referred to as the "TI" (test instrument) throughout this bulletin.

a. Model Variations. Variations among models are described in text.

b. Time and Technique. The time required for this calibration is approximately 1 hour, using the microwave or dc low technique.

2. Calibration Data Card, DA Form 2416. Forms, records, and reports required for calibration personnel at all levels are prescribed by TB 750-25. DA Form 2416 must be annotated in accordance with T750-25 for each calibration performed.

3. Calibration Description. TI parameters and performance specifications which pertain to this calibration are listed in table 1.

Table 1. Calibration Description

Test instrument parameters	Performance specifications
Zero carryover	Less than 0.5% of FS when zeroed on most sensitive scale
Range	0.01 to 10 mw in 7 ranges: -20 to +10 dBm in 5 -dBm steps
Accuracy	Model 431C From +20°C to +35°C - .01 mw range, ±2% of FS, .03 mw range, ±1.5% of FS; all other ranges, ±1% of FS. From 0°C to +55°C, ±3% of FS on all ranges. Model 431B From +20°C to +35°C, ±3% of FS on all ranges. From 0°C to +55°C, ±5% of FS on all ranges.

**SECTION II
EQUIPMENT REQUIREMENTS**

4. Equipment Required. Table 2 identifies the specific equipment used in this calibration procedure. This equipment is issued with the secondary transfer calibration standards sets 6695-00-621-7877 and 4931-00-525-8175 and maintenance calibration shelter AN/TSM-55. Alternate items may be used by the calibrating activity when the equipment listed in table 2 is not available. The items selected must be verified to perform satisfactorily prior to use and must bear evidence of current calibration. The equipment must meet or exceed the minimum use specifications listed in table 2. The accuracies listed in table 2 provide a four-to-one accuracy ratio between the standard and TI. Where the four-to-one ratio cannot be met, the actual accuracy of the equipment selected is shown in parenthesis.

5. Accessories Required. The accessories listed in table 3 are issued with the secondary transfer calibration standards sets 6695-00-621-7877 and 4931-00-525-8175 and maintenance calibration shelter AN/TSM-55. When necessary, these items may be substituted by equivalent items unless specifically prohibited.

Table 2. Minimum Specifications of Equipment Required

Item	Common name	Minimum use specifications	Manufacturer and model (part number)		
			Transfer (6625-00-621-7877)	Maintenance (AN/TSM-55)	Maintenance (4931-00-525-8175)
A1	AUTOTRANSFORMER	Range: 105 to 125 V ac	General Radio, Model W10MT3AS3 (7910809)	TS 510/U	General Radio, Model W10MT3AS3 (7910809)
A2	DC POWER SUPPLY ¹	Range: 0 to 25 vdc		TS 2734/U	John Fluke, Model 760A
A3	DC VOLTMETER	Range: 0.5 to 25 vdc Accuracy: ±0.05%	Dana, Model 5703-S-2127 (7912606)	John Fluke, Model 882AB (TS-2843/U)	Hewlett-Packard, Model 3490A
A4	FREQUENCY COUNTER	Range: 9950 to 10,275 Hz Accuracy: ±0.025%	Systron-Donner Model 1037-M (7910823) (P/O 7910628)	AN/USM-257A	Hewlett-Packard, Model 5245L
A5	POWER METER CALIBRATOR	Range: 0.01 to 10 mw Accuracy: ±0.25%	Hewlett-Packard 8402B (7911026)	AN/USM-317	
A6	RESISTANCE ¹ DECADE	Range: 1 k ohm Accuracy: ±0.05%			Biddle-Gray, Model 71-631 (7910328)
A7	RESISTANCE ¹ DECADE	Range: 10 k ohm Accuracy: Nominal			CMC, Model 240C (7907234)
A8	THERMISTOR MOUNT	Range: 10 MHz to 12.4 GHz Accuracy: ±5% 10 MHz to 10 GHz 8.2 to 12.4 GHz	Hewlett-Packard, Models 478A (7910461) X486A (7910460)	MX-7772/U Hewlett-Packard, Model X486A	Hewlett-Packard, Model 478A (7910461)

¹Not used if power meter calibrator (A5) is available.

Table 3. Accessories Required

Item	Common name	Description and Part Number
B1	Adapter	Double banana jack to BNC plug (7909401)
B2	Adapter	Double banana jack to phone plug (7907566)
B3	Cable ¹	24-in., single banana plug terminations (red) (7907497)
B4	Cable ¹	24-in., single banana plug terminations (black) (7907498)
B5	Cable	36-in., BNC plug to alligator clips (7909410)
B6	Termination	50-ohm, N jack (374 NM)

¹Three required when using maintenance standard set 4931-00-525-8175.

**SECTION III
PRELIMINARY OPERATIONS**

6. Preliminary Instructions

a. The instructions outlined in this section are preparatory to the calibration process. Personnel should become familiar with the entire bulletin before beginning the calibration.

b. Items of equipment used in this procedure are referenced within the text by common name and item identification number as listed in tables 2 and 3. For the identification of equipment referenced by item numbers prefixed with A, see table 2, and for prefix B, see table 3.

WARNING

HIGH VOLTAGE is used during the performance of this calibration. DEATH ON CONTACT may result if personnel fail to observe safety precautions.

7. Equipment Setup

a. Connect autotransformer (A1) to the power source and adjust for 115 volts ac.

CAUTION

Throughout this procedure, make sure the TI is deenergized while connecting or disconnecting a thermistor mount or when repositioning the MOUNT RES switch.

b. Connect the TI to autotransformer.

c. Adjust the TI mechanical zero setscrew clockwise until the pointer is left of zero, moving up scale. Stop when the pointer indicates zero.

NOTE

If pointer overshoots zero indication during adjustment, repeat **c** above.

d. Adjust the zero setscrew approximately 15 degrees counterclockwise to free the setscrew from the meter movement.

e. If the pointer moves while freeing the setscrew, repeat **c** and **d** above.

f. Connect 200-ohm thermistor mount (A8) to the TI, using cable furnished with the TI and terminate the mount with coaxial termination (B6).

g. On model 431C, set the CALIB FACTOR PERCENT switch to 100 and leave it in this position for the remainder of the procedure.

**SECTION IV
CALIBRATION PROCESS**

NOTE

Unless otherwise specified, verify the results of each test and take corrective action whenever the test requirement is not met before continuing with the calibration.

NOTE

When indications specified in paragraphs **8** through **11** are not within tolerance, perform the oscillator frequency check in paragraph **12** and the power supply check in paragraph **13** before making adjustments. Do not perform the procedures in paragraphs **12** and **13** if all other parameters are within tolerance.

NOTE

Remove top and side covers from the TI only for adjustment. When adjustment is completed, reinstall the covers.

8. Coarse Null

a. Performance Check

- (1) Position the TI RANGE switch to the .01 MW position.
- (2) Adjust the TI ZERO controls for a 25 to 75 percent indication on the TI meter.
- (3) Turn the RANGE switch to NULL.
- (4) Adjust the NULL, control for minimum indication on the TI meter.
- (5) Repeat (2) through (4) above until the TI meter pointer is within the NULL region. If the meter pointer does not indicate within the NULL region, perform **b** below.

NOTE

During maintenance calibration, if a 100-ohm thermistor mount is not available, disregard (6) through (8) below.

- (6) Connect 100-ohm thermistor mount (A8) to the TI.
- (7) Set the TI MOUNT RES switch to 100.
- (8) Repeat (2) through (5) above.

b. Adjustments. On model 431C, adjust L1 (fig. 1)(L102, fig. 2 on model 431B) for null on the TI.

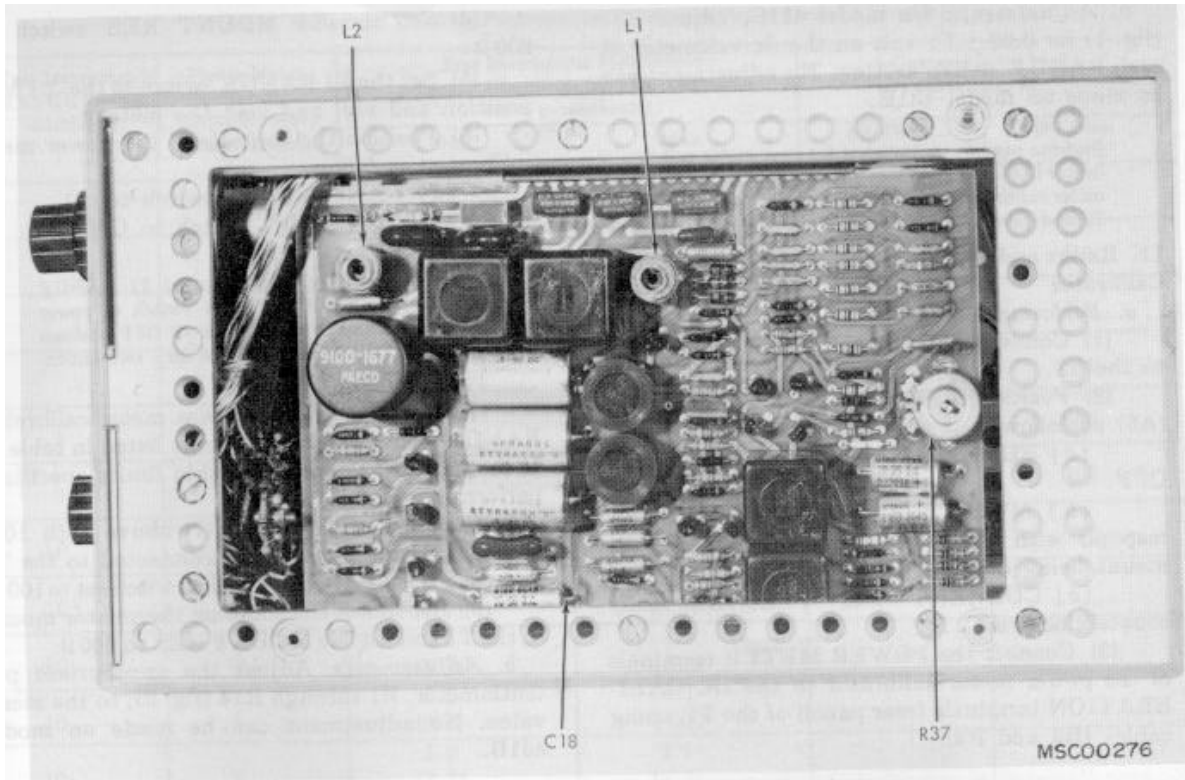

Figure 1. Right interior view - model 431C..

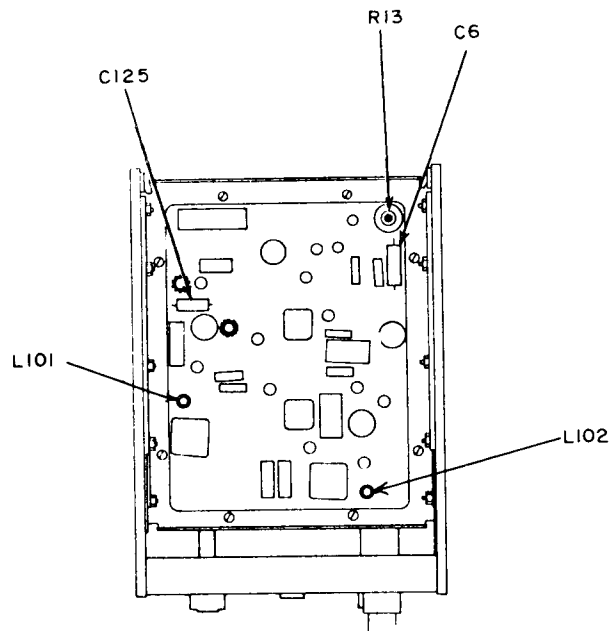

Figure 2. Top interior view - model 431B.

9. Zero and Vernier

a. Performance Check

(1) On model 431C, connect dc voltmeter (A3) to the TI DVM output (rear panel) using adapter (B1) and if necessary cables (B3) and (B4).

(2) On model 431B, connect resistance decade (A6)(set at 1000 ohms) to the TI RECORDER output, using adapter (B2) and cables (B3 and B4). Connect the dc voltmeter to the same terminals of the resistance decade, using cables (B3 and B4) if necessary.

(3) Position the TI RANGE switch to the .01 MW position and adjust the zero controls for 0.00 volt dc on the dc voltmeter.

(4) Turn the TI RANGE switch to .03-, .1-, .3-, 1-, 3-, and 10-MW positions while observing dc voltmeter. If the dc voltmeter does not indicate between -0.01 and +0.01 volt in each position of the RANGE switch, perform **b** below.

b. Adjustments. On model 431C, adjust R37 (fig. 1) for 0.00 \pm .01 volt on the dc voltmeter at each RANGE switch setting. No adjustment can be made on model 431B.

NOTE

Perform paragraph 10 below if power meter calibrator (A5) is available as a standard. If a power meter calibrator is not available, omit paragraph 10 and proceed to paragraph 11.

10. Range and Tracking Check with Power Meter Calibrator

a. Performance Check

(1) Connect 200-ohm thermistor mount (A8) to the TI.

(2) Position the controls of power calibrator (A5) as follows:

(a) FUNCTION switch to CURRENT OFF.

(b) MOUNT RESISTANCE to correspond with the resistance of the thermistor mount being used.

(c) CURRENT and VERNIER fully counterclockwise.

(3) Connect the POWER METER terminals of the power meter calibrator to the DC CALIBRATION terminals (rear panel) of the TI, using cables (B3 and B4).

(4) Set the TI MOUNT RES switch to 200 Ω .

(5) Set the TI RANGE switch to the .01 MW position and null and zero the meter.

TB 9-6625-086-35

(6) Position the controls of the power meter calibrator as follows:

- (a) RANGE (MW) switch to .01.
- (b) FUNCTION switch to CAL.

NOTE

After each change in position of TI RANGE switch, turn the FUNCTION switch of power meter calibrator to the CURRENT OFF position and adjust the TI zero controls for a zero indication.

(7) Turn the TI and power meter calibrator RANGE switches to the settings listed in table 4. If the indications are not within limits specified, perform **b** below.

Table 4. Range and Trucking Performance Check (with Power Meter Calibrator)

Test Instrument RANGE switch settings	Power Meter Calibrator RANGE (MW) switch settings	Test Instrument Indications (mw) (Readings for Model 431B are in parenthesis)		Adjustments for Model 431C (fig. 3)	
		Min	Max	200-Ohm Mount	100-Ohm Mount
.01	.01	0.0098 (0.0097)	0.0102 (0.0103)	R14	R1
.03	.03	0.0295 (0.0291)	0.0305 (0.0309)	R13	R2
.1	.1	0.099 (0.097)	0.101 (0.103)	R12	R3
.3	.3	0.297 (0.291)	0.303 (0.309)	R11	R4
1	1	0.990 (0.970)	1.010 (1.030)	R10	R5
3	3	2.970 (2.910)	3.030 (3.090)	R9	R6
10	10	9.900 (9.700)	10.100 (10.300)	R8	R7
10 ¹	8	7.9 (7.7)	8.1 (8.3)		
10	6	5.9 (5.7)	6.1 (6.3)		
10	4	3.9 (3.7)	4.1 (4.3)		
10	2	1.9 (1.7)	2.1 (2.3)		

(8) Repeat (1) through (7) above with 100 ohm thermistor mount (A8) connected to the TI and with the TI MOUNT RES switch set to 100Ω.

(9) Reconnect the 200-ohm thermistor mount to the TI and set the MOUNT RES to 200Ω.

b. Adjustments. Adjust the appropriate potentiometer, R1 through R14 (fig. 3), to the mean value. No adjustment can be made on model 431B.

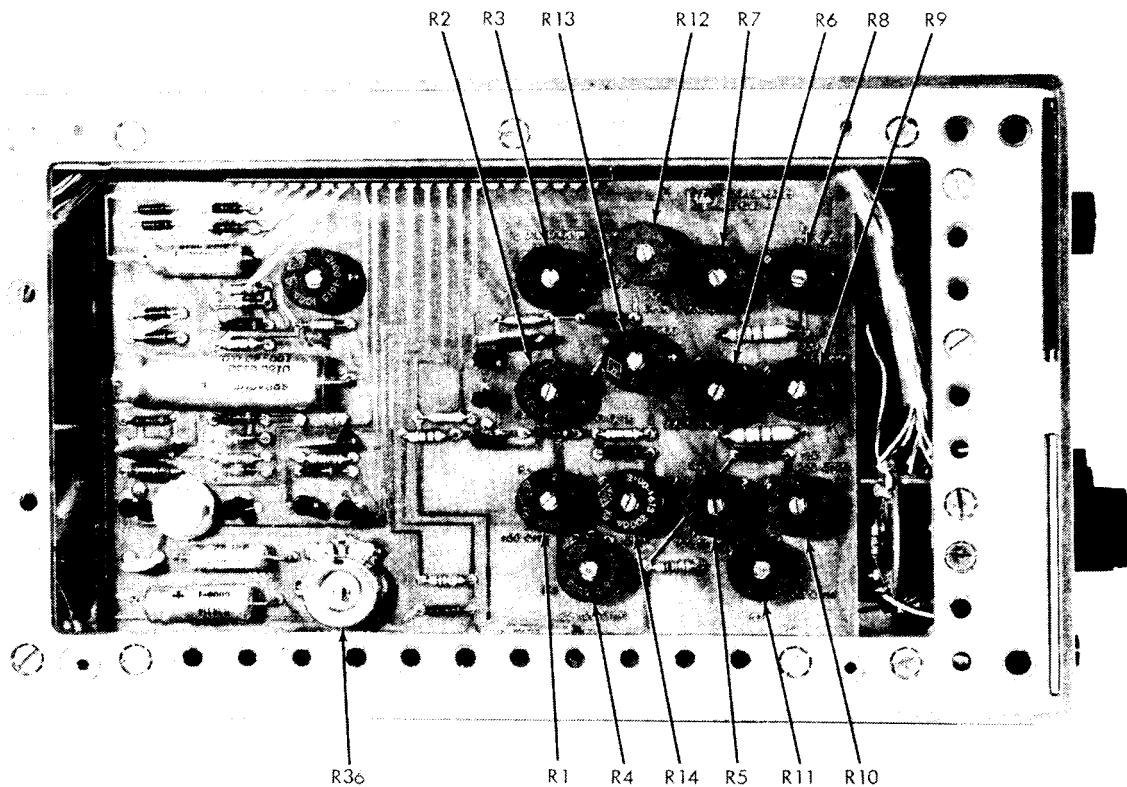

Figure 3. Left interior view, model 431C.

11. Range and Tracking Check Without Power Calibrator

a. Performance Check

- (1) Connect the equipment as shown in figure 4.
- (2) Set resistance decade (A7) to 10 kΩ. This 10 kΩ value can be decreased as necessary to obtain full scale indication on TI.
- (3) Set resistance decade (A6) to 1000 ohms.

TB 9-6625-086-35

(4) Set the TI MOUNT RES switch to agree with the thermistor mount (A8) being used.

(5) Set the TI RANGE switch to .01 MW and null and zero the meter.

(6) Adjust dc power supply (A2) for a full-scale (.01 mw) indication on the TI. If dc voltmeter (A3) indication is not within the limits specified in table 5, perform **b** below.

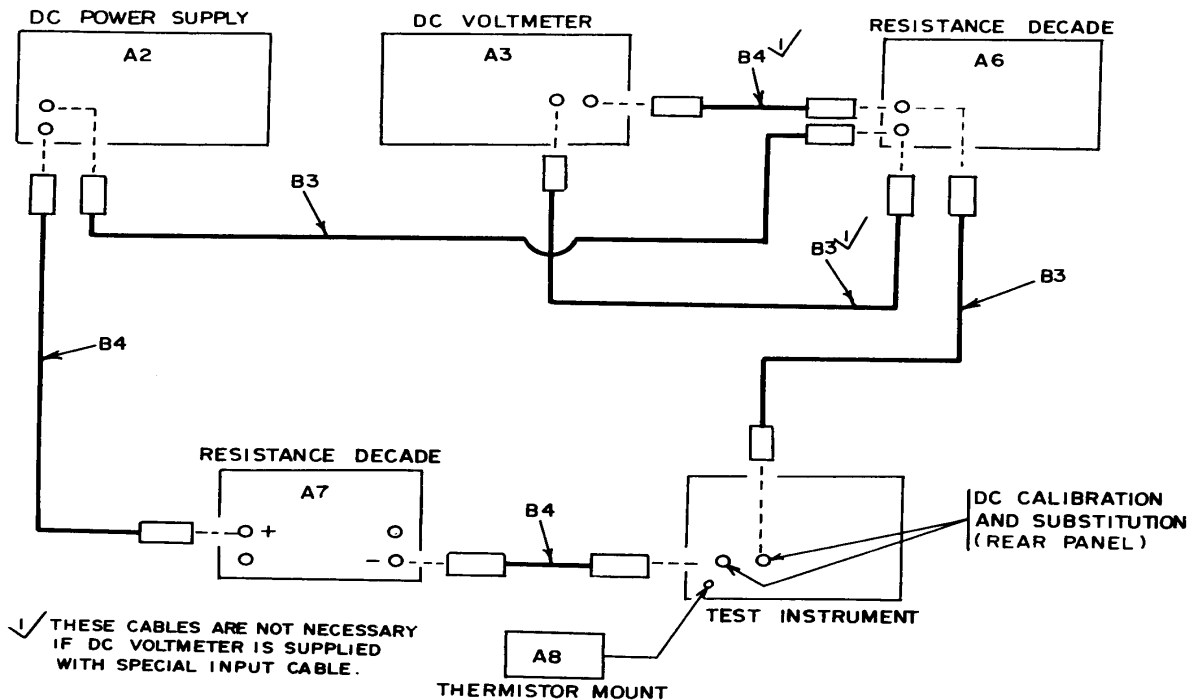

Figure 4. Range and tracking check without power meter calibrator.

Table 5. Range and tracking Performance Check (Without Power Meter Calibrator)

Test Instrument Switch Settings	Test Instrument Indication	Dc Voltmeter Indications (vdc) (Readings for Model 431B are in Parenthesis)				Adjustments for Model 431C (fig. 3)	
		200-Ohm Mount		100-Ohm Mount		200-Ohm Mount	100-Ohm Mount
		Min	Max	Min	Max		
.01	.01	.438 (.434)	.456 (.460)	.619 (.613)	.645 (.651)	R14	R1
.03	.03	.763 (.752)	.787 (.798)	1.08 (1.06)	1.12 (1.13)	R13	R2
.1	.1	1.40 (1.37)	1.42 (1.45)	1.98 (1.94)	2.02 (2.06)	R12	R3
.3	.3	2.43 (2.38)	2.47 (2.52)	3.43 (3.36)	3.49 (3.56)	R11	R4
1	1	4.43 (4.34)	4.51 (4.60)	6.26 (6.13)	6.38 (6.51)	R10	R5

Table 5. Range and tracking Performance Check (Without Power Meter Calibrator) - Continued

Test Instrument Switch Settings	Test Instrument Indication	Dc Voltmeter Indications (vdc) (Readings for Model 431B are in Parenthesis)				Adjustments for Model 431C (fig. 3)	
		200-Ohm Mount		100-Ohm Mount		200-Ohm Mount	100-Ohm Mount
		Min	Max	Min	Max		
3	3	7.67 (7.52)	7.83 (7.98)	10.84 (10.6)	11.06 (11.3)	R9	R6
10	10	14.00 (13.7)	14.28 (14.6)	19.80 (19.4)	20.20 (20.6)	R8	R7
10	8	12.52 (12.3)	12.78 (13.0)	17.71 (17.4)	18.07 (18.4)		
10	6	10.84 (10.6)	11.06 (11.3)	15.34 (15.0)	15.64 (16.0)		
10	4	8.85 (8.67)	9.03 (9.21)	12.52 (12.3)	12.78 (13.0)		
10	2	6.26 (6.13)	6.38 (6.51)	8.85 (8.67)	9.03 (9.21)		

NOTE

Each time the TI RANGE switch is changed, turn the dc power supply off and zero the TI meter.

(7) Repeat the technique in (5) and (6) above for the remaining positions of the TI RANGE switch. If both a 200-ohm and 100-ohm thermistor mount is available, perform (1) through (6) above for both mounts.

b. Adjustments. Adjust R1 through R14 (fig. 3) as appropriate for model 431C. No adjustment can be made on model 431B.

12. Oscillator Frequency

NOTE

Do not perform the oscillator frequency check if all parameters in paragraphs **8** through **11** above are within tolerance.

a. Performance Check

(1) On model 431C, connect frequency counter (A4) to the positive end of C18 (fig. 1) and ground, using cable (B4). On model 431B, connect the counter to the positive end of C125 (fig. 2) and ground.

(2) Connect 200-ohm thermistor mount (A8) to the TI and terminate the mount with termination (B6).

(3) Set the TI MOUNT RES switch to 200Ω.

(4) If the frequency counter does not indicate between 9,990 and 10,010 Hz for model 431C, perform **b(1)** below. For model 431B, if the frequency counter does not indicate between 10,025 and 10,275 Hz, perform **b(2)** below.

NOTE

Perform (5) through (7) below if the TI is to be used with a 100-ohm thermistor mount.

- (5) Disconnect the 200-ohm thermistor mount from the TI.
- (6) Connect 100-ohm thermistor mount (A8) to the TI and turn the MOUNT RES switch to 100Ω.
- (7) The frequency counter will indicate between 9,950 and 10,050 Hz.

b. Adjustments

- (1) Adjust L2 (fig. 1) on model 431C.
- (2) Adjust L101 (fig. 2) on model 431B.

13. Power Supply

a. Performance Check

NOTE

Do not perform the power supply check if all other parameters are within tolerance.

- (1) Connect dc voltmeter (A3) to pin W of terminal board XA2 (fig. 5) and ground. For model 431B, connect the voltmeter to the negative end of C6 (fig. 2) and ground.

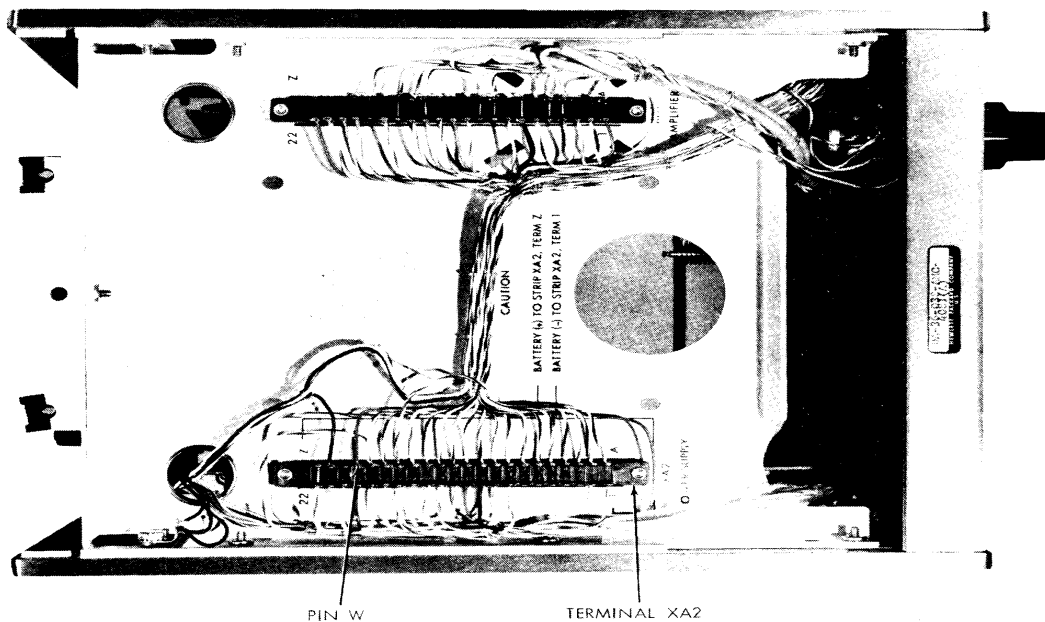

Figure 5. Top internal view-model 431C.

(2) If the dc voltmeter does not indicate between -17.98 and -18.02 volts dc, perform **b** below.

(3) Vary the output of autotransformer (A1) between 105 and 125 volts ac. The dc voltmeter indication will remain within the limits specified in (2) above.

(4) Adjust the autotransformer for a 115-volt ac output.

b. Adjustments. Adjust R36 (fig. 3) for model 431C or R13 (fig. 2) for model 431B.

14. Final Procedure

a. Deenergize and disconnect all equipment and replace TI protective cover.

b. When all parameters are within tolerance, annotate and affix DA Label 80 (US Army Calibrated Instrument). When the TI receives limited or special calibration, annotate and affix DA Label 163 (US Army Limited or Special Calibration). When the TI cannot be adjusted within tolerance, repair the TI in accordance with the maintenance manual. When repair is delayed for any reason or the TI cannot be repaired with local resources, annotate and affix DA Form 2417 (US Army Calibration System Rejected Instrument) and inform the owner/user accordingly in accordance with TB 750-25.

TB 9-6625-086-35

By Order of the Secretary of the Army:

FRED C. WEYAND
General, United States Army
Chief Of Staff

Official:

PAUL T. SMITH
Major General, United States Army
The Adjutant General

Distribution:

To be distributed in accordance with DA Form 12-34C, Block No. 319, requirements for calibration publications.

US GOVERNMENT PRINTING OFFICE: 1975 -- 641-219-5023

PIN: 010318-000