

ALIGNMENT INSTRUCTIONS.

ELECTRO SOUND STEREO. AX.

UNDERNEATH VIEW OF COIL UNIT

NOTE: The IF transformers KF360, KSF361 & KRF362 are combined for AM and FM. The AM slugs being towards dial.

AM SECTION. Set selectivity control to sharp position - Adjust volume control for maximum
Connect output meter to speaker - Use Signal Generator 30% AM modulated

Order	Connect Sig. Gen. to	Press Button	Tune Gen. to	Tune Receiver to	Adj. for Maximum Output at Approx. 50 mW	Position of Slug or Trimmer
1	Front section of Gang	Radio	455 KC	540 KC	L6	Top of KRF362
2	" " " "	"	455 KC	540 KC	L5	Bottom of KRF362
3	" " " "	"	455 KC	540 KC	L4	Top of KSF361
4	" " " "	"	455 KC	540 KC	L3	Bottom of KSF361
5	" " " "	"	455 KC	540 KC	L2	Top of KF 360
6	" " " "	"	455 KC	540 KC	L1	Bottom of KF 360
Repeat Orders 1 to 6 until true maximum is obtained						
7	Aerial Terminal	Radio	455 KC	540 KC	L7 for minimum output	Coil Unit
8	" " " "	S.W.	9 MC	9 MC	L8 (Osc.) L9 (Aerial)	" "
9	" " " "	S.W.	21 MC	21 MC	Tr1 (Osc.) Tr2 (Aer.)	" "
Repeat Orders 8 and 9 until true maximum is obtained						
10	Aerial Terminal	M.W.	3 MC	3 MC	L10 (Osc.) L11 (Aerial)	" "
11	" " " "	M.W.	7 MC	7 MC	Tr3 (Aerial)	" "
Repeat Orders 10 and 11 until true maximum is obtained						
12	Aerial Terminal	Radio	600 KC	600 KC	L12 (Osc.) L13 (Aerial)	" "
13	" " " "	"	1500 KC	1500 KC	Tr4 (Osc.) Tr5 (Aerial)	" "
Repeat Orders 12 and 13 until true maximum is obtained.						

FM SECTION. Press FM Button - Connect VTVM across C321 (3MF) on Ratio Detector
Connect output meter to speaker - Adjust Tr6 for minimum noise level
For IF alignment connect Signal Generator to V1 6AQ8 by means of a metal cylinder pushed firmly over the valve ensuring that the cylinder does not touch the chassis.
Feed sufficient Signal so that VTVM reads always 10 volts negative.

Order	Connect Sig. Gen. to	Tune Gen. to	Tune Receiver to	Adj. for Maximum Reading on VTVM	Position of Slug or Trimmer
1	To Cylinder over V1	10.7 MC	92 MC	L23	Top of KRF362
2	" " " V1	10.7 MC	92 MC	L22	Top of KSF361
3	" " " V1	10.7 MC	92 MC	L21	Bottom of KSF361
4	" " " V1	10.7 MC	92 MC	L20	Top of KF 360
5	" " " V1	10.7 MC	92 MC	L19	Bottom of KF 360
6	" " " V1	10.7 MC	92 MC	L18	Top of Tuner
7	" " " V1	10.7 MC	92 MC	L17	Bottom of Tuner
Repeat Orders 1 to 7 until true maximum is obtained					
Connect 50 μ A meter as shown in Fig. 1					
8	To Cylinder over V1	10.7 MC	92 MC	L24 for zero on 50 μ A meter	Bottom of KRF362
9	Modulate Generator 30% AM To Cylinder over V1	10.7 MC	92 MC	R324 tab pot for minimum sound output	Under KRF362
Repeat Orders 9 and 10					
10	Dipole Terminals	92 MC	92 MC	Tr7 (Osc.) Tr6 (Aerial)	Top of Tuner

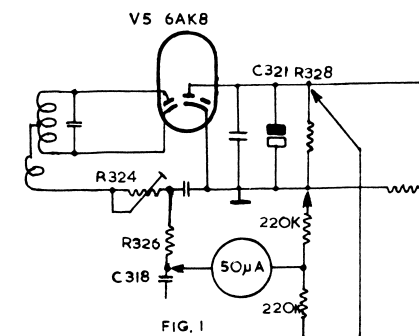
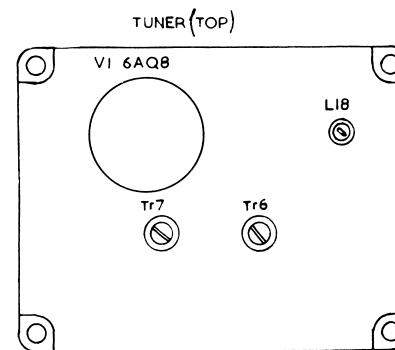
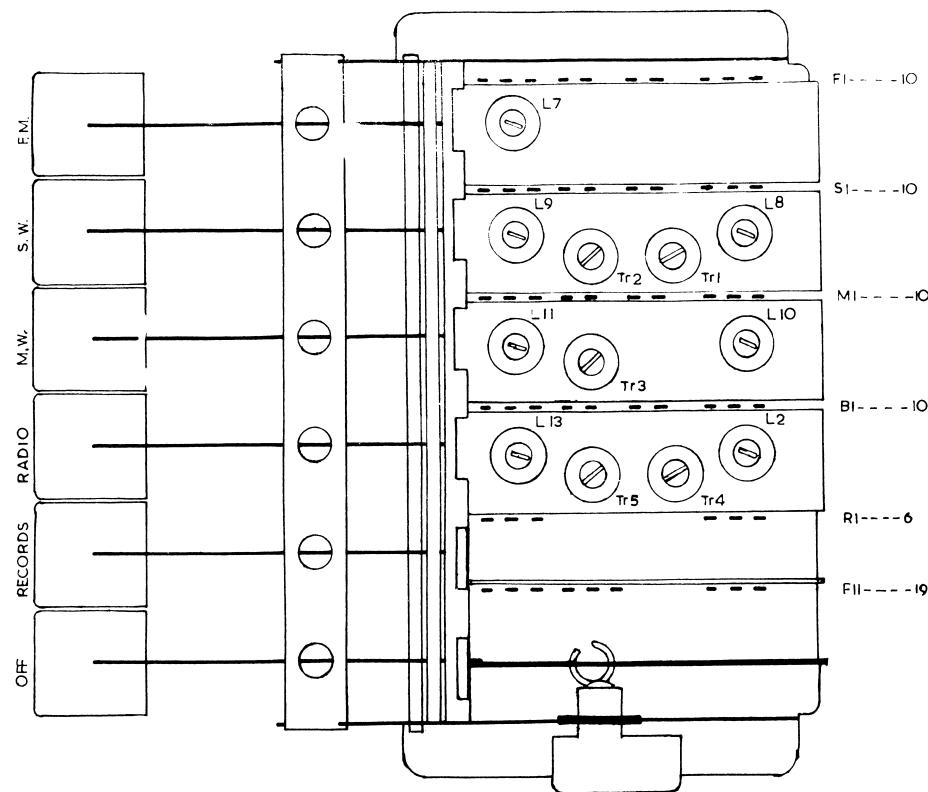

Electrosound Pty. Ltd.
 Sydney / Australia

Circuit "SUPER STEREO AX"

DRAWN <i>Sol</i>	DESIGN <i>Sol</i>
CHECKED <i>Glenn</i>	APPROVED <i>J.M.</i>
DRAWING NO 60-1	ISSUED 15. 6. 60

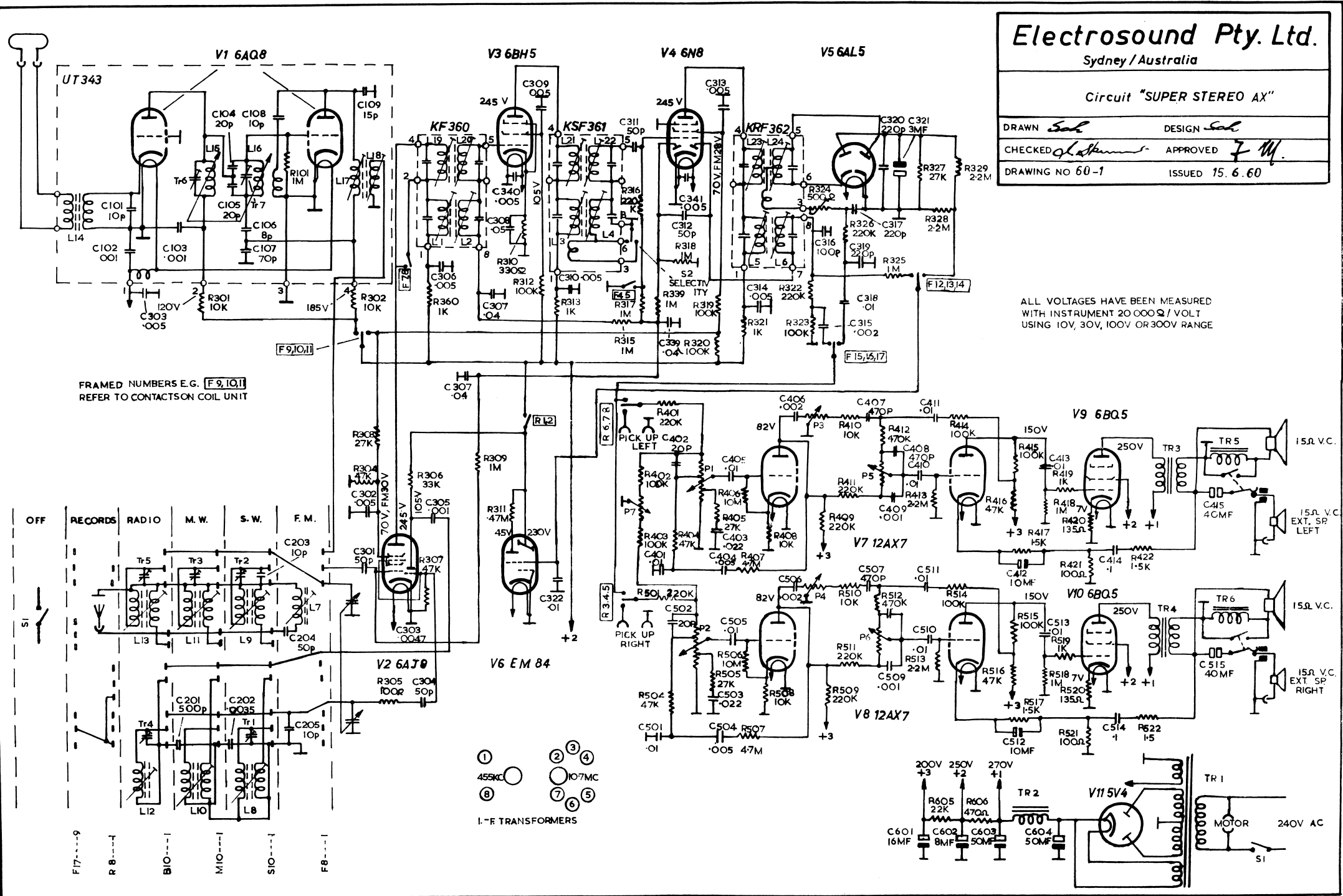

ALL VOLTAGES HAVE BEEN MEASURED WITH INSTRUMENT 20 000 Ω / VOLT USING 10V, 30V, 100V OR 300V RANGE

FRAMED NUMBERS E.G. [F9,10,11] REFER TO CONTACTS ON COIL UNIT

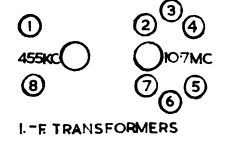

- F17---9
- R 8---4
- B10---1
- M10---1
- S10---1
- F 8---1