



RADIO CORPORATION PTY. LTD. BULLETIN: R-14.

DIVISION OF ELECTRONIC INDUSTRIES LTD.

126-130 GRANT STREET, SOUTH MELBOURNE, S.C.4.

File: Installation
Receiver

Date : 20/4/50.

Page: 1.

TECHNICAL BULLETIN

SUBJECT-

INSTALLATION INSTRUCTIONS

for fitting

MODEL "CS" 12 VOLT 6 VALVE CAR RADIO INTO THE AUSTIN A90 CAR

ANTENNA.

The antenna used is a four section telescopic whip type which is mounted on the car fender (mudguard) on the driving side in the position shown in the diagram. Clean off all paint, duco or grease for $\frac{1}{2}$ inch around hole on underside of fender.

ASSEMBLY OF SUB-UNIT TO FRONT OF RECEIVER CASE.

1. Insert shielded lead from receiver through large hole in sub unit and fasten the lug on end of this lead under the head of the screw in the corner of the 7-pin socket.
2. Insert 7-pin plug on lead from receiver through large hole in sub unit and fit on to 7-pin socket.
3. Mount sub-unit on to front of receiver can with the $\frac{5}{32}$ in. dia. screws supplied in accessory package. Fit plug lead cover plate to side of sub-unit with a $\frac{5}{32}$ in. dia. screw and one self-tapping screw supplied in accessory package.

INSTALLATION OF SPEAKER.

1. Remove trim panel from driving side (panel has speaker grille mounted in position).
2. Mark and cut out slot in body panel to correspond to the lead slot in the speaker plate.
3. Mount the speaker plate into the hole in the body panel using four No. 2BA screws and S/P washers supplied in accessory package.
4. Refit trim panel, running the speaker lead up between the body and trim panels.

INSTALLATION OF RECEIVER INTO CAR.

1. Drill hole in firewall and hole in front face of receiver box as shown in diagram. Clean off all paint, grease or duco for $\frac{1}{2}$ inch around the holes to provide a good electrical contact.
2. Remove the six control knobs from along the bottom edge of the instrument panel.
3. Remove the instrument cluster sub-panel from behind the instrument panel by unscrewing the four screws in the corners of the centre section of the panel.
4. Remove the expanded metal grille from the centre of the panel. This is accomplished by pressing the grille in through the opening in the panel, care must be exercised not to strip the speednuts off the moulded excutcheon.
5. Assemble control head to sub-panel by inserting control cables through holes in firewall. Mount control head to panel with two No. 2BA screws supplied in accessory package.
6. Screw sub-panel back into position and refit control knobs.
7. Insert a small screwdriver into hole in receiver case and into the rubber moulding on the condenser gang shaft and then turn screw driver fully clockwise.

8. Connect speaker lead and antenna lead-in to their respective sockets on receiver case.
9. Mount receiver in position in receiver box and securely clamp in position.
10. Turn control head tuning knob fully clockwise until pointer reaches max. travel of the dial, then insert splined end of tuning control cable through hole in receiver can into rubber moulding on condenser gang shaft. Clamp cable under small clip on sub-unit.
11. Insert end of volume control cable into collar on volume control shaft and securely tighten grub screws.
12. Connect A+ lead from control head to "spare" terminal post on junction block on firewall.

INTERFERENCE ELIMINATION

No spark plug suppressors are required.

Distributor Suppressor: Insert a distributor suppressor, part No. PR314, in the high tension lead from the coil a few inches from where the lead enters the distributor. Make sure the lead is fitted well into the suppressor and that good contact is made. Securely bind the lead at both ends of the suppressor with adhesive tape.

Ignition Coil Condenser: Install a metal clad .5 MFD. by-pass condenser part No. PC545 on the battery terminal of the ignition coil keeping the lead as short as possible. The condenser is mounted under the bolt which fastens the ignition coil mount strap. The other side of the condenser is internally connected to the condenser case which forms the other contact to the car when mounted. **Generator Condenser:** Install a .5 MFD. metal clad condenser part No. PC545 on the generator. Connect the lead from the condenser to the armature terminal not the field terminal, make the lead as short as possible. The condenser is mounted on the generator mount bolt nearest to the armature terminal.

NOTE: The nuts and mounting positions of the by-pass condensers must be entirely free of paint, grease or duco varnish to ensure a good electrical contact.

Parts List	Part No.	
Antenna	: Antenna only, less lead-in, fully extended 49", fully retracted 15"	M223
Antenna Lead-in	: 48" overall length	M224
Volume Control	: .5 megohm	PR661
Speaker	: 5" round type, less leads, shielding braid, nylex covering and plug	K124
Speaker Plug	: 2 pin	336/30C
Dist. Suppressor	: Screw type, 12 volt	PR314
By-pass Cond.	: .5MFD. 200V. DCW. Metal clad	PC545
Fuse	: 15 amp.	PM219
Pointer Assy.	:	A103/323
Control Knob	:	15/306-1
Knob Spring	:	86/71
7 Pin Socket Assy.	: On sub unit	A104/323
7 Pin Plug Assy.	: On receiver lead	104/58-1
Dial Reading	:	14/665-1
Dial Lamp	: 6-8V. 0.3A. min. bay. base G3 $\frac{1}{2}$ bulb	M127
Excutechon	:	1/324
Rear Mount Nut	: On receiver case rear mount screw	3/478-14
2BA Screw	: Mounts control head	2/415
Control Cable Assy.:	Volume	A105/324-1
Control Cable Assy.:	Tuning	A104/324-1
Cable Clamp	:	45/73-1
Connector	: Male, dial lamp lead	32/304
Connector	: Female, dial lamp lead	39/305

Antenna Accessory Package A105/671 contains rubber tube 35/671, sealing washer 34/671 and mount washer 33/671; these parts are for water-proofing lead-in connection to base of antenna on underside of fender.

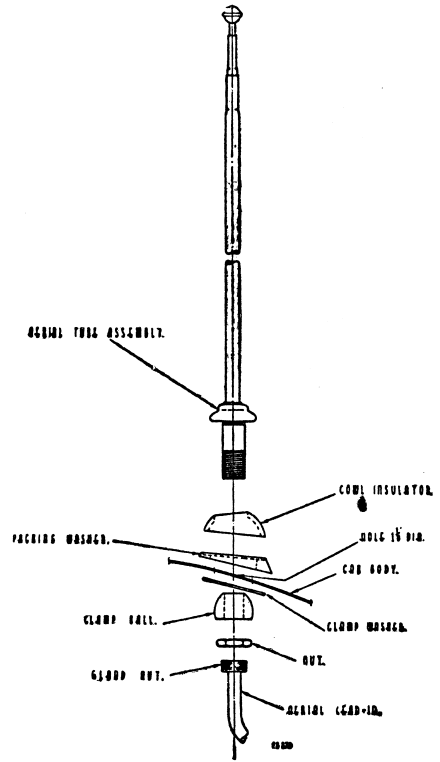
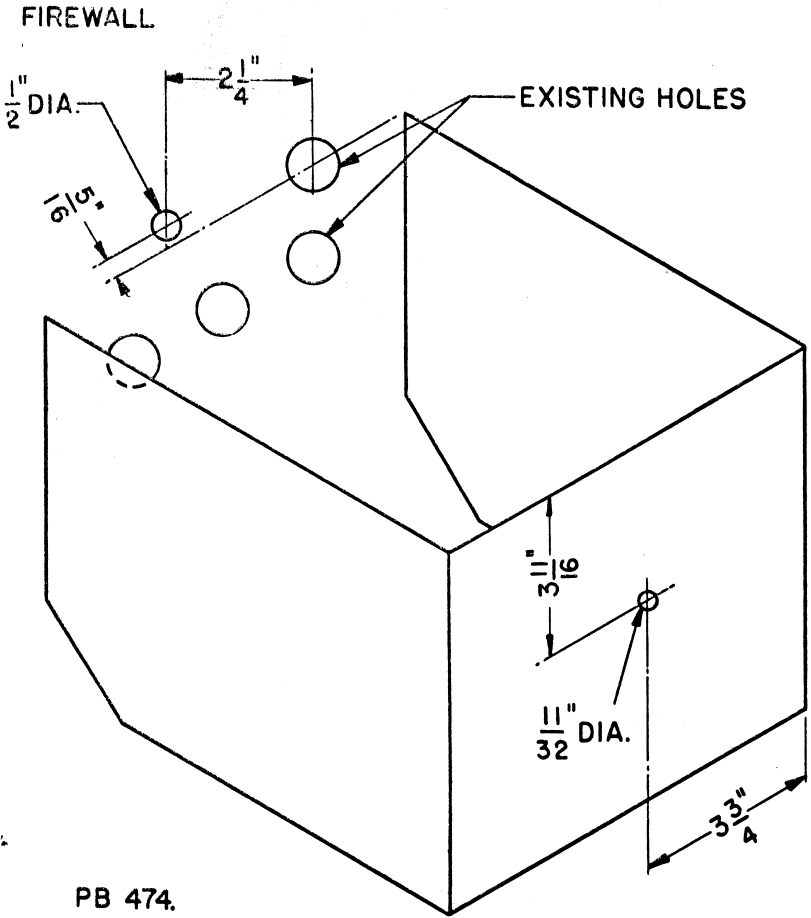

DRILLING OF RECIEVER BOX

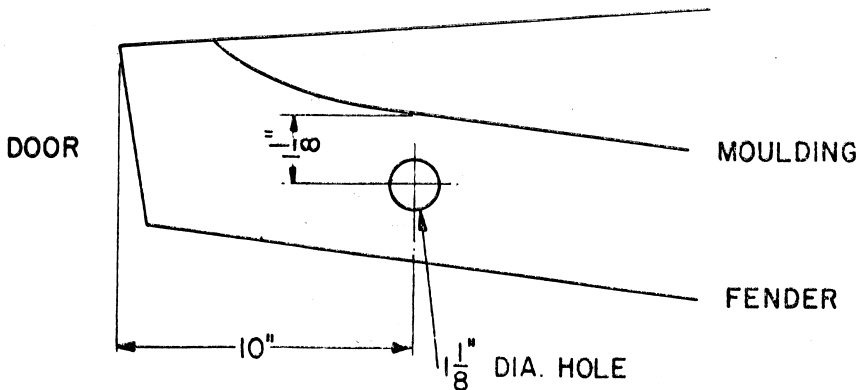

TOP VIEW OF RIGHT HAND SIDE FENDER SHOWING AERIAL MOUNTING HOLE.

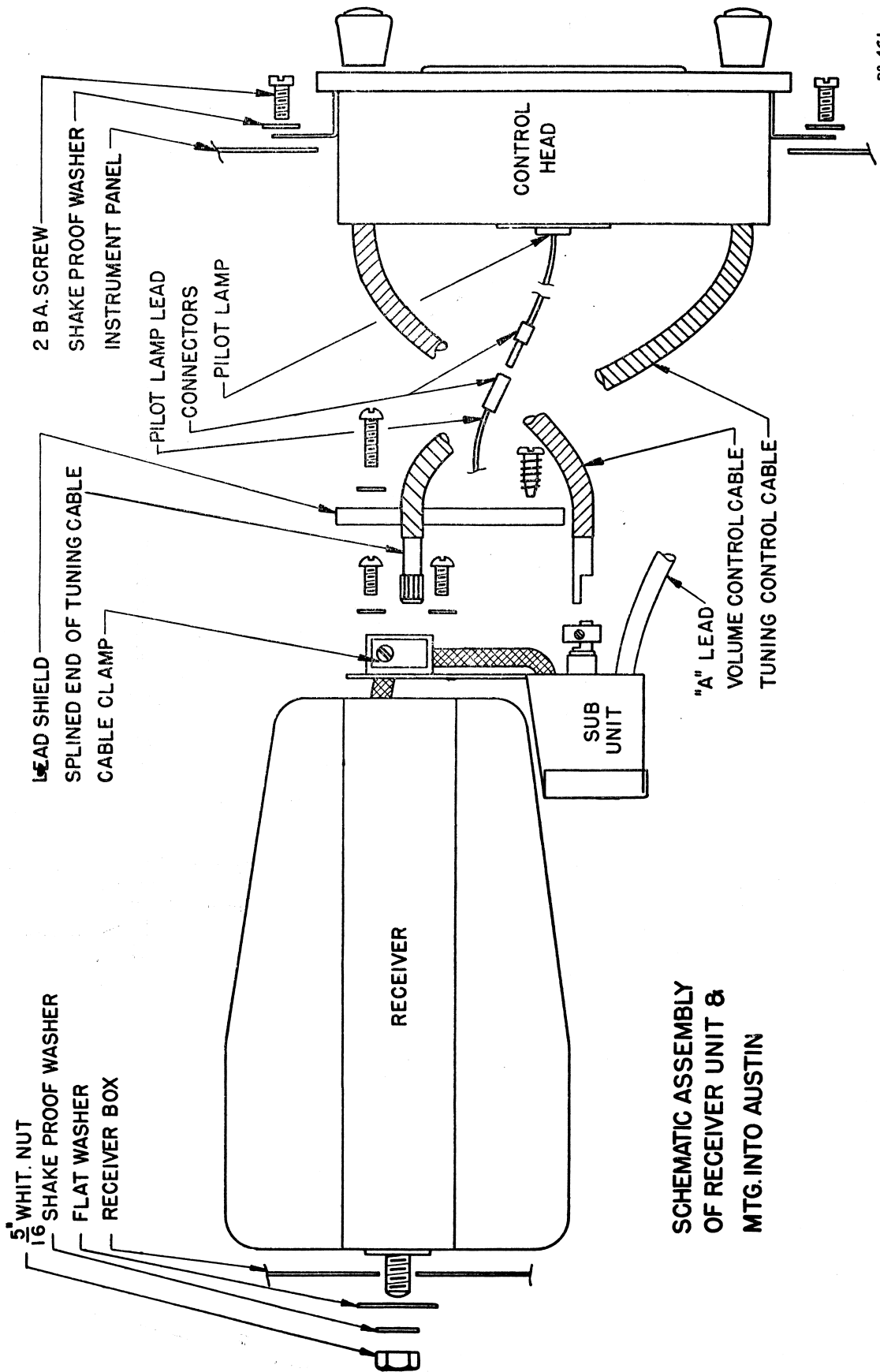

SCHEMATIC ASSEMBLY
OF RECEIVER UNIT &
MTG. INTO AUSTIN