



MULLARD MASTER RADIO

MODEL MABS 1052

SPECIFICATIONS

(Subject to alteration without notice)

Tuning Range	530-1620 kc/s.
Intermediate Frequency	455 kc/s.
Power Supply			
Batteries	Types 753, 3753 or 5753 pack ; A, 9V ; B, 90V.
Mains	200-250V 40-60 c/s.
Battery Consumption	14 mA.



VALVE EQUIPMENT & VOLTAGE ANALYSIS

Valve Function	Valve No.	Valve Type	Plate Volts		Screen Volts		Filament Volts		
			Batt.	Mains	Batt.	Mains	Batt.	Mains	
R.F. Amplifier	V1	1T4	90	97	30	30	1.5	1.3	
Frequency Converter	V2	1R5	90	97	45	45	1.5	1.3	
I.F. Amplifier	V3	1T4	90	97	30	30	1.5	1.3	
Demodulator, A.V.C., and 1st Audio	V4	1S5	20	20	26	26	1.5	1.3	
Power Amplifier	V5	3V4	87	93	90	97	3.0	2.6	
Rectifier	V6	EZ82	Cathode to L16 C.T., 125V.					6.4	

NOTE: These voltages are measured with an 1,000 ohms per volt meter, except 1S5 plate and screen which are measured with a V.T.V.M., and may vary $\pm 10\%$ from the quoted figures. Measurements are made between the socket points indicated and chassis except filaments which are measured across the valve socket lugs. The receiver should be in a "no signal" condition.

TO REMOVE CHASSIS FROM CASE.

Remove the power cord from the mains outlet and the receiver. Close the shutter, open the rear cover of the case (the fastening screws are captive and the holes in the cover are slotted) and remove the battery pack. Unsolder the two connections from the chassis to the aerial loop on the tuning control side. Disengage the on/off switch actuating arm from the shutter.

Lay the receiver face downwards on some protective material and from outside the case, remove the two top securing screws. Remove the two securing screws and nut plates at the bottom of the chassis. The chassis may now be lifted from the case but in doing so the power transformer end should be cleared first.

Refitting the chassis to the case is a reversal of the removal procedure. Care should be taken to see that the on/off switch actuating arm is engaged with the shutter before any mounting screws are put into position. The top mounting holes are slotted to allow the chassis to be adjusted to bring the control rollers into correct fitting in the dial cut-out. The screws at the bottom of the chassis should be tightened last.

MAINS VOLTAGE ADJUSTMENT.

The power transformer is provided with three primary winding tappings—200/210 volts, 230/240 volts and 250 volts—for the adjustment of the receiver to the supply voltage at the point of installation. The receiver is adjusted at the factory to the 230/240 volts tapping.

DIAL CALIBRATION ADJUSTMENT.

If dial calibrations are incorrect by an equal amount of error over the band, the condition may be corrected by moving the cursor on the dial driving cord. This may be done through a specially provided slot in the rear of the dial assembly.

ALIGNMENT.

Alignment should be carried out with the receiver operating from the battery pack. The chassis should be removed from the case and the bottom cover shield should be in position.

The cores for the secondaries of the I.F. transformers are located in the top of the cans, those for the primaries are in the bottom of the cans. When trimming the I.F. circuits care should be taken not to screw the iron cores in too far otherwise undesired coupling may give rise to a false peak. A preliminary screwing to the outer edge of the former of all iron cores should be made. Then when trimming is being carried out the cores should not be screwed in beyond the first peak. Metallic tools should not be used for I.F. transformer trimming.

For R.F. alignment use the I.F. dummy. The trimmer layout is shown as an inset to the circuit diagram. Before commencing alignment, set the dial cursor, with the tuning gang fully closed, to the right hand edge of the state designation numerals. Alignment frequencies are—600 kc/s (7ZL), adjust oscillator coil core; and 1420 kc/s (3XY), adjust oscillator and R.F. capacitive trimmers. Signal generator should be applied between V1 signal grid and chassis. **No attempt should be made to adjust the core of the R.F. coil.**

The loop should be adjusted with the chassis fitted to the case, the battery pack in position and the rear cover closed. The signal generator (1420 kc/s) should be applied through the I.F. dummy in series with a 500 ohms resistor, to the lug strip in the left hand case end—the lug near the rear cover is aerial. For the purposes of better control the receiver can be desensitized by connecting a 5000 ohms carbon resistor and a 0.1mF capacitor in series between V2 signal grid and chassis.

MISCELLANEOUS COMPONENTS

No. on Dial Parts Diagram	Description	Code No.	No. on Dial Parts Diagram	Description	Code No.
—	Assembly, carrying handle	CR.523.405	—	Foot, mounting (front), 2x	CS.240.021
—	Assembly, case end	CR.248.014	—	Foot, mounting (rear), 2x	CS.240.019
—	Assembly, chassis shield	CR.500.407	—	Link, carrying handle, 4x	CS.365.282
—	Assembly, clicker (A.C./batt. switch)	CR.450.044	—	Nut, rear foot mtg., 2x	CH.629.201
—	Assembly, contact pin	CZ.365.109	—	Pad, felt (mounting feet), 4x	CS.424.016
9	Assembly, cursor	CR.480.652	—	Plate, cover (power plug)	CS.462.359
—	Assembly, dial mounting	CR.248.439	—	Plate, insul. (power plug)	CS.110.799
—	Assembly, front cover	CR.572.092	—	Plate, nut (chassis mounting), 2x	CS.271.026
—	Assembly, rear cover	CR.572.093	—	Plug, 5 pin battery	CZ.365.309
—	Assembly, pot. mtg. bracket	CR.280.613	5	Pulley, brass	CS.360.205
—	Assembly, rear cover fastening	CR.115.608	6	Pulley, plastic, 2x	CS.359.602
—	Assembly, shutter	CR.572.282	—	Ring, "C" (tuning spindle)	CS.281.802
—	Assembly, switch (A.C./batt.)	CZ.200.052	—	Ring, "C" (sw. arm to spindle)	CS.281.801
—	Assembly, switch arm	CR.526.005	3	Ring, dial cord	CS.281.807
—	Assembly, switch lever	CR.526.006	—	Roller, tuning control	CS.381.409
—	Assembly, switch sleeve	CR.431.604	—	Roller, volume control	CS.381.410
4	Assembly, tuning spindle	CR.371.216	—	Scale, dial	CS.412.332
—	Badge, Mullard, 2x	CS.436.415	—	Screw, chassis support to case, 2x	CS.258.847
—	Baffle	CS.008.246	—	Screw, c/sunk (front cover fixing), 2x	CS.259.818
—	Bank, A.C./batt. switch	CZ.200.514	—	Screw, rear cover fastening, 2x	CS.258.834
—	Block, batt. locating (narrow)	CS.468.206	—	Screw, shutter spring anchor	CS.250.010
—	Block, batt. locating (wide)	CS.468.210	—	Socket, valve (7 pin min.), 5x	CZ.369.318
—	Body, power plug	CS.218.704	—	Socket, valve (noval)	CZ.369.702
—	Bracket, baffle clamping, 2x	CS.222.599	—	Spacer, link (carrying handle), 4x	CS.213.600
—	Bracket, speaker mounting, 3x	CS.222.582	—	Spacer, on/off switch mtg., 2x	CS.213.190
—	Clamp, capacitor mtg., 3x	CH.777.375	—	Spacer, A.C./batt. sw. mtg., 2x	CS.213.179
—	Clamp, capacitor mtg., 3x	CS.234.820	—	Spring, carrying handle, 2x	CS.104.010
—	Clamp, loop connecting wire, 2x	CS.282.449	2	Spring, dial drum	CS.210.029
—	Clip, capacitor mtg.	CH.777.374	—	Spring, shutter	CS.210.024
—	Clip, coil can mtg., 6x	CS.235.833	—	Spring, valve retaining	CS.210.602
—	Clip, tuning roller	CH.777.371	—	Support, dial L.H.	CS.217.206
—	Clip, volume roller	CH.777.370	—	Support, dial R.H.	CS.217.205
—	Contacts, power plug, 2x	CS.102.423	—	Switch, on/off (battery)	CZ.210.107
—	Cloth, grille	CE.081.92	—	Switch, on/off (mains)	CZ.210.108
7	Cord, dial drive	CS.361.832	—	Washer, c/sunk (chassis support)	CS.467.055
1	Drum, dial	CS.360.008	—	Washer, speaker mounting	CH.671.103
—	End, case	CS.217.013	—	Window, dial	CS.030.008

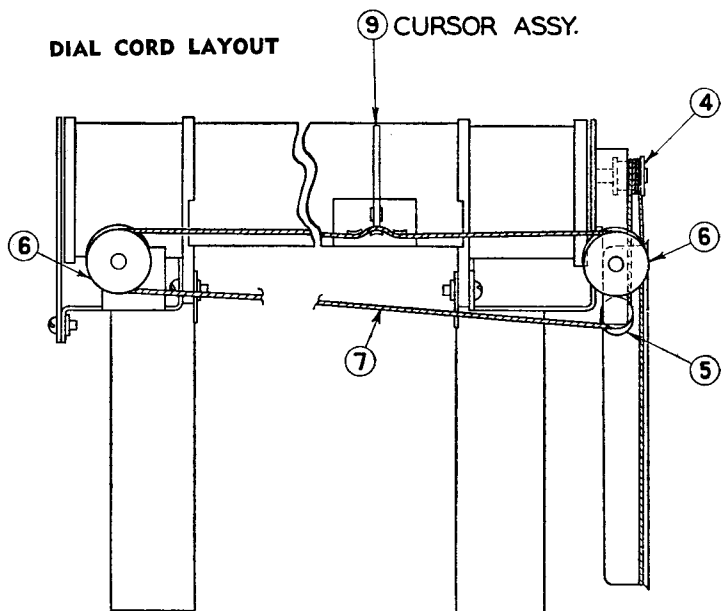
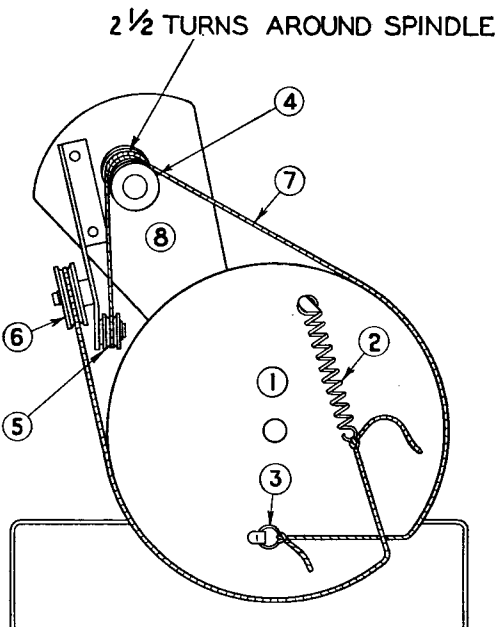

L	1, 2, 3	4, 5	6, 7	8, 9	10, 11	12, 13, 14	15	16	17	18	19	20, 21, 22	23	24	25	26	27, 28	29	30	31	32	33	34	35	36	37	38	39	40	41	42	43	44	45	46	47	48	49	50
C	1, 2, 3	4, 5	6, 7	8, 9	10, 11	12, 13, 14	15	16	17	18	19	20, 21, 22	23	24	25	26	27, 28	29	30	31	32	33	34	35	36	37	38	39	40	41	42	43	44	45	46	47	48	49	50
R	1, 2, 3	4, 5	6, 7	8, 9	10, 11	12, 13, 14	15	16	17	18	19	20, 21, 22	23	24	25	26	27, 28	29	30	31	32	33	34	35	36	37	38	39	40	41	42	43	44	45	46	47	48	49	50
V	1, 2, 3	4, 5	6, 7	8, 9	10, 11	12, 13, 14	15	16	17	18	19	20, 21, 22	23	24	25	26	27, 28	29	30	31	32	33	34	35	36	37	38	39	40	41	42	43	44	45	46	47	48	49	50

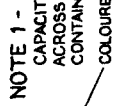
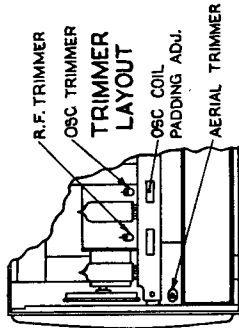

NOTE 1 -
CAPACITIVE SHUNTS SHOWN
ACROSS I.F. WINDINGS ARE
CONTAINED WITHIN THE CANS
COLOURED SPOT.

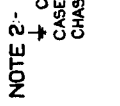

NOTE 2 -
CHASSIS EARTH ONLY.
CASE IS ISOLATED FROM
CHASSIS.

EXTERNAL AERIAL & EARTH
CONNECTIONS. FOR DETAILS
REFER TO TEXT.

I.F. TRANSFORMER BASE VIEW OF LUGS

R.F. & OSCILLATOR COIL LUG PANEL VIEW OF LUGS

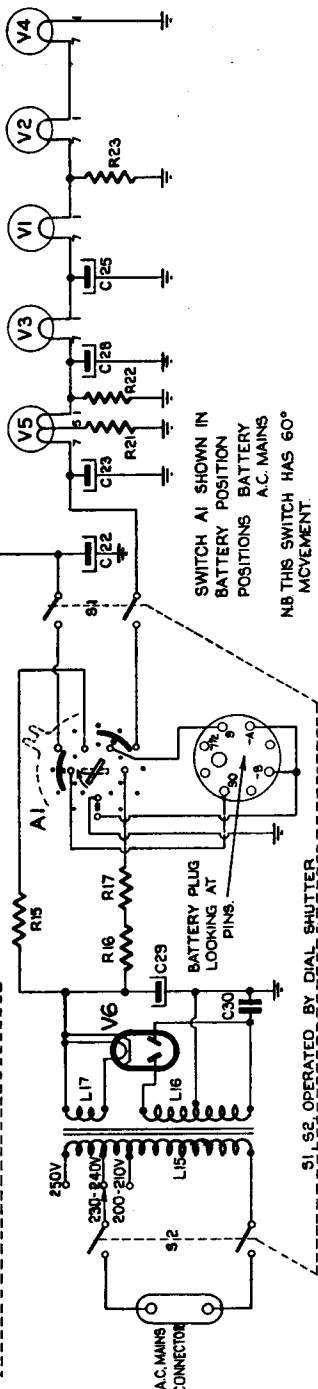
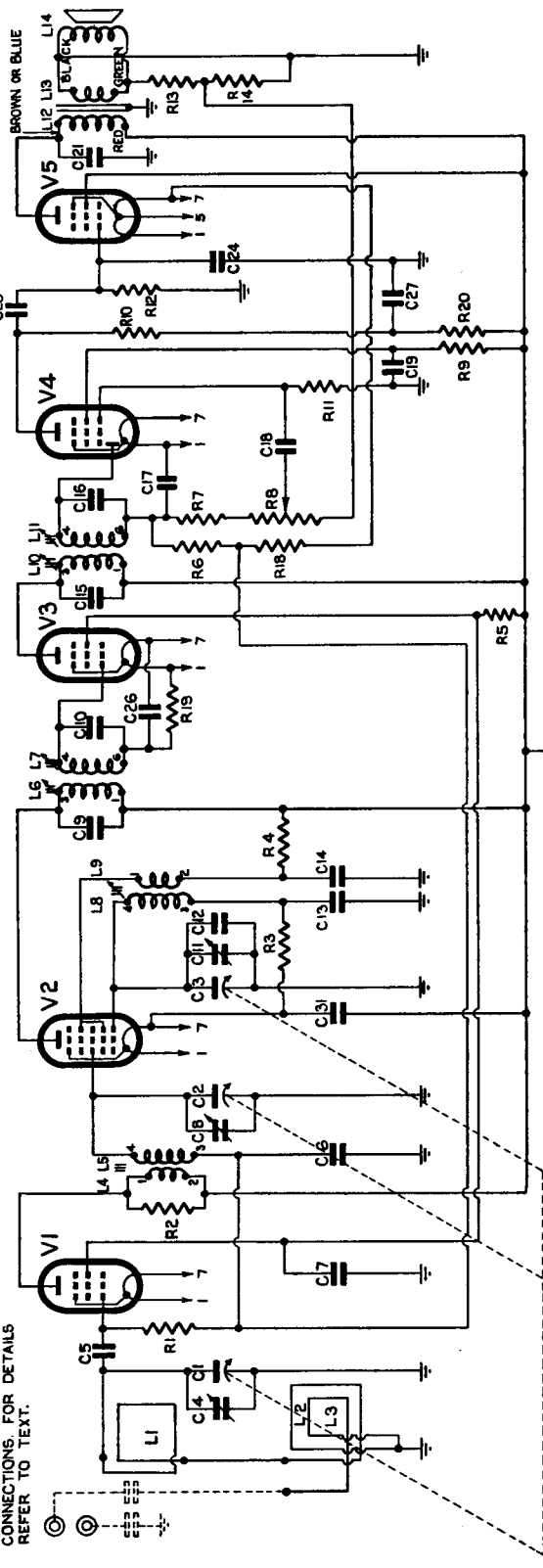

SWITCH AS SHOWN IN
BATTERY POSITION
POSITIONS BATTERY
A.C. MAINS
NB THIS SWITCH HAS 60°
MOVEMENT.

S1, S2 OPERATED BY DIAL SHUTTER

CAPACITORS

No.	Description	Code No.
C1, 2, 3	Tuning capacitor	CZ.108.204
C4	50pF compr. trimmer	
C5	500pF mica	
C6	0.1mF 200V paper	
C7, 26, 27	0.05mF 200V paper	
31	30pF air trimmer	CZ.113.700
C8, 11	Part of 1st I.F. transformer	
C9, 10	20pF mica	
C12	560pF mica 2%	CZ.066.122
C13	0.001mF mica	
C14	Part of 2nd I.F. transformer	
C15, 16	100pF mica	
C17, 24	0.001mF 600V paper	
C18, 30	0.01mF 600V paper	
C19, 20	0.02mF 400V paper	
C21	24mF 350V electrolytic	
C22	100mF 10V electrolytic	
C23, 28	20mF 10V electrolytic	
C25	50mF 200V electrolytic	
C29		

RESISTORS

No.	Description	Code No.
R1, 10, 12	0.5 megohm ½W carbon	
R2, 5, 7	100,000 ohms ½W carbon	
R3	50,000 ohms ½W carbon	
R4	20,000 ohms ½W carbon	
R6, 19	2 megohms ½W carbon	
R8	1 megohm carbon potentiometer	CZ.029.305
R9	3 megohms ½W carbon	
R11	10 megohms 1W carbon	
R13	400 ohms ½W carbon 10%	
R14	50 ohms ½W carbon	
R15	2,000 ohms 1W carbon	
R16, 17	1,300 ohms 5W W/W 5%	CZ.011.322
R18	5 megohms ½W carbon	
R20	250,000 ohms ½W carbon	
R21	2,000 ohms ½W carbon	
R22, 23	1,000 ohms 1W carbon	

COILS

No.	Description	Code No.
L1	Aerial Loop	CZ.333.006
L2	Aerial Loop	CZ.333.007
L3		
L4	R.F. Coil	CZ.323.228
L5	(1 red and 1 blue spots)	
L6	I.F. Transformer	CZ.320.427
L7		
L8	Oscillator Coil	CZ.330.602
L9	(1 blue spot)	
L10	I.F. Transformer	CZ.320.428
L11		
L12	Output Transformer	CZ.345.010
L13		
L14	Speaker	CZ.161.124
L15	Power Transformer	CZ.344.075
L16		
L17		

REPLACEMENT OF TUNING SPINDLE AND/OR ROLLER AND/OR DIAL SUPPORT MOULDING.

It is necessary to remove the dial assembly from the tripod supporting bracket for this operation. To remove the tuning spindle remove the retaining clip and withdraw the spindle. The roller may now be removed. At this stage the dial support moulding may be readily removed.

EXTERNAL AERIAL AND EARTH.

For improved signal pick-up in difficult areas an external aerial and earth may be used. Pin contacts are provided in the left-hand case end for making these connections. It is first necessary though that they be connected to the loop. This should be done through an 0.001mF 600V paper capacitor in each lead. The lug nearer to the rear cover is the aerial on the lug strip mounted in the case end.

It is also necessary to provide access to the external aerial and earth contacts by suitably cutting away the rear cover at the appropriate place.

REPLACEMENT OF VOLUME CONTROL ROLLER AND/OR POTENTIOMETER AND/OR SUPPORT MOULDING.

These operations may be performed without the need to remove the dial assembly.

Remove the retaining clip and spring for the on/off switch actuating arm and remove the on/off switches. Unscrew the potentiometer mounting plate and withdraw the plate, potentiometer and roller. The roller is a friction fit on the spindle and may be removed with a firm pull.

The left hand dial support moulding may now be removed by unscrewing.

IMPORTANT! In ordering spare parts, quote CODE NUMBER of part and MODEL NUMBER of Receiver. In claiming free replacement under GUARANTEE, return defective part PROMPTLY and quote MODEL and SERIAL NUMBER of Receiver and DATE OF PURCHASE.