

COMPONENT LOCATION

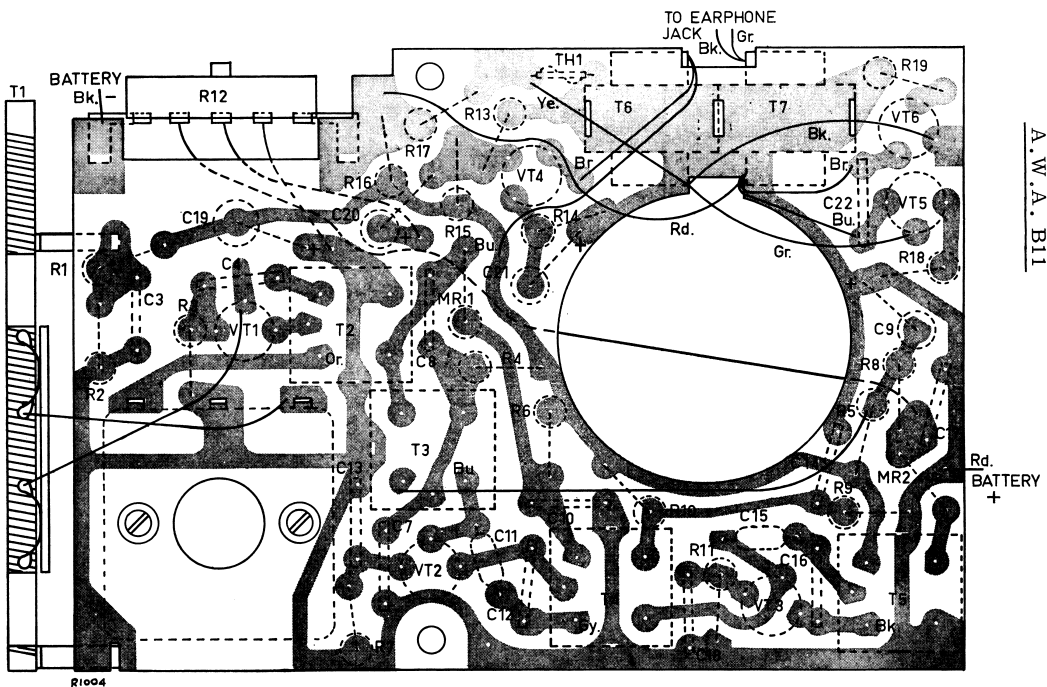

The assemblies represented above are viewed from the wiring side of the board.

The printed wiring, on the near side of the board, is presented in phantom view superimposed on the component layout of the reverse side.

VOLTAGE CHART

All voltages negative with respect to printed board earth (positive terminal of battery).

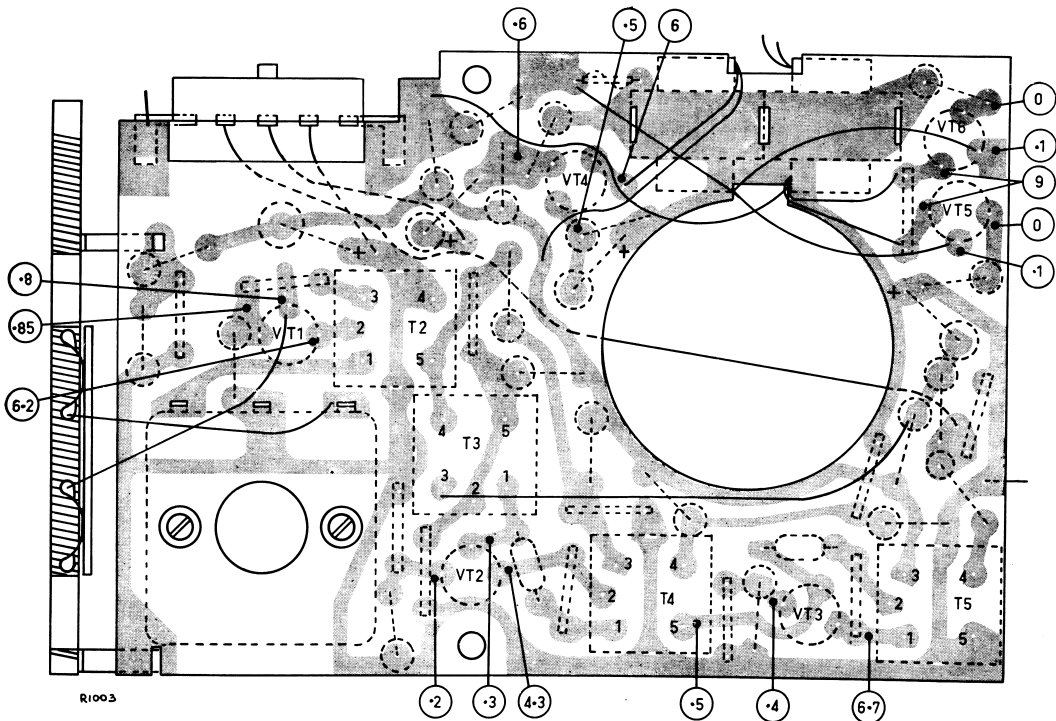

The assemblies represented above are viewed from the wiring side of the board.

The printed wiring, on the near side of the board, is presented in phantom view superimposed on the component layout of the reverse side.

A.W.A. MODEL B11

