

Mounting Diagram

— Conductor Side —

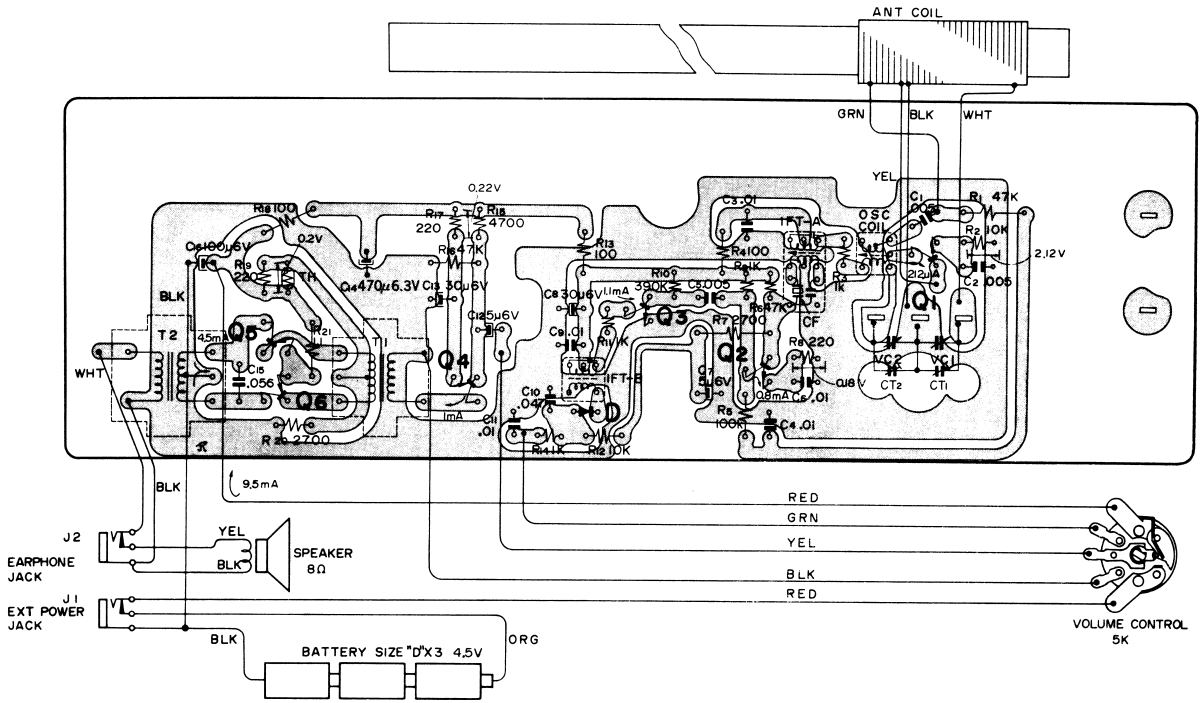

Mounting Diagram

— Component Side —

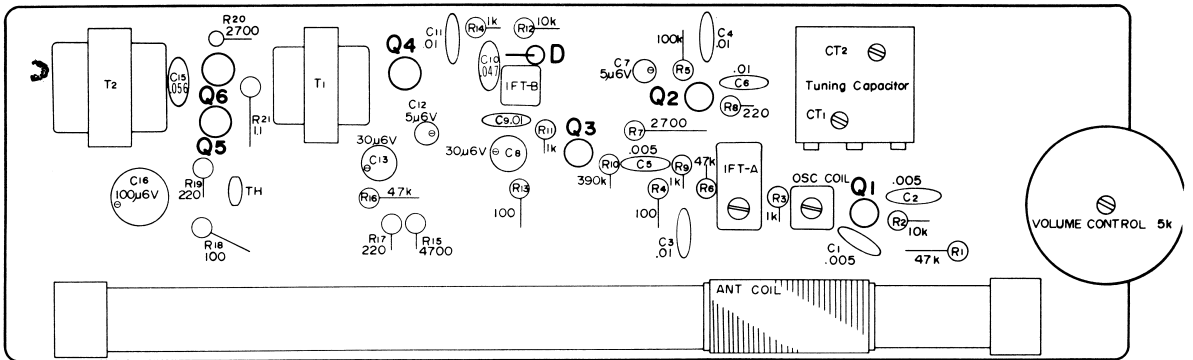

C₁₄ : Mounted on the conductor side.

Q1,2,3 2SC537

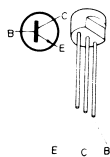

Q4 2SB186
Q5,6 2SB187

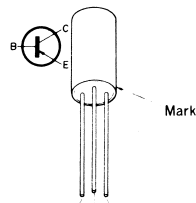

S34-1

Sony 6R-22

Exploded Diagram

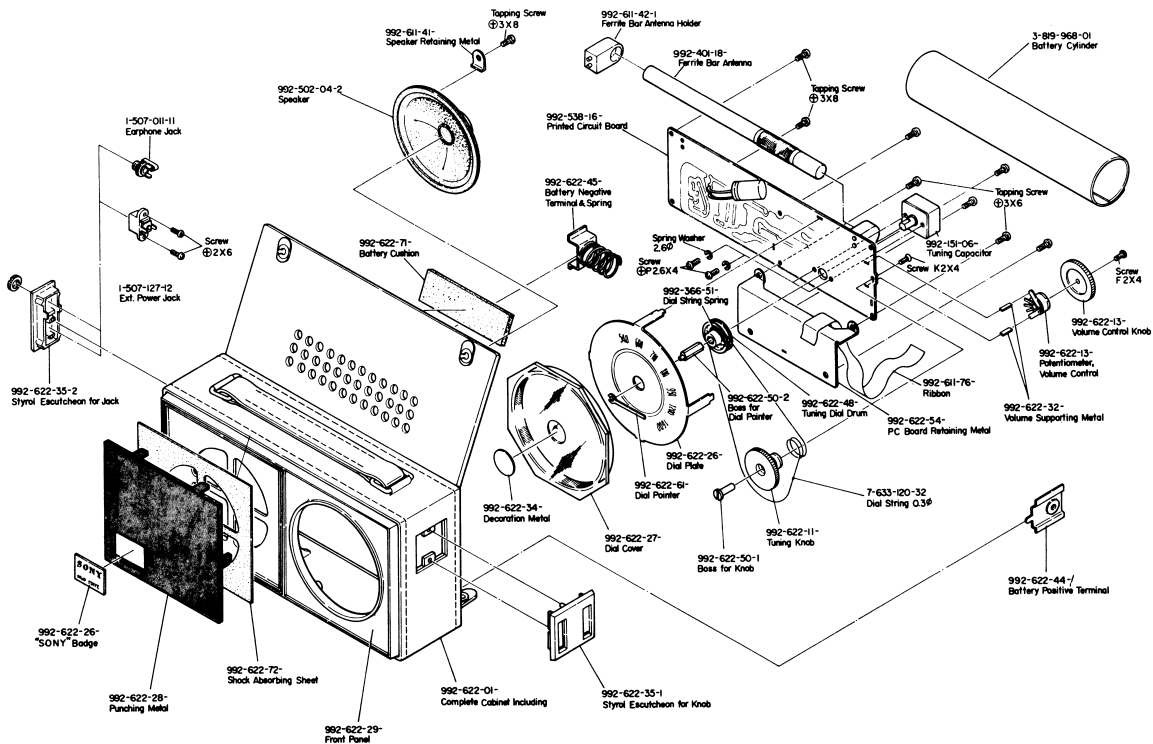

Removal of Printed Circuit Board

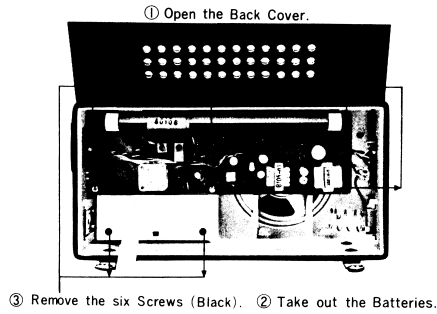

① Open the Back Cover.

③ Remove the six Screws (Black). ② Take out the Batteries.

(Fig. 1)

Removal of Dial Plate

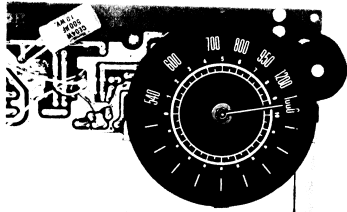

① Remove the Dial Pointer.

(Fig. 2)

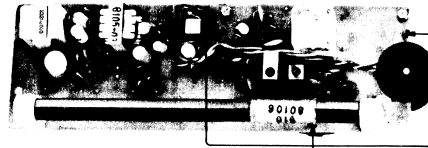

② Twist back three tabs counter-clockwise and push them out.

(Fig. 3)

Frequency Coverage and Tracking Adjustment

Adj. Item	S.S.G. (Standard Signal Generator) Coupling	S.S.G. Freq.	Receiver Dial Setting	Connect V.T.V.M.	Adjust	Remarks
Frequency Coverage	Loop Antenna	520 kHz (1,000 Hz 30% AM)	Counter-clockwise	To Earphone Jack with 8Ω load resistor in parallel.	OSC Coil	Adjust for maximum meter reading Volume Control: Max. Power Supply: DC 4.5V
		1,680 kHz ()	Clockwise		OSC Trimmer (CT ₂)	
Tracking	— ditto —	620 kHz ()	Tune to 620 kHz signal	— ditto —	ANT Coil	
		1,400 kHz ()	Tune to 1,400 kHz signal		ANT Trimmer (CT ₁)	

Schematic Diagram

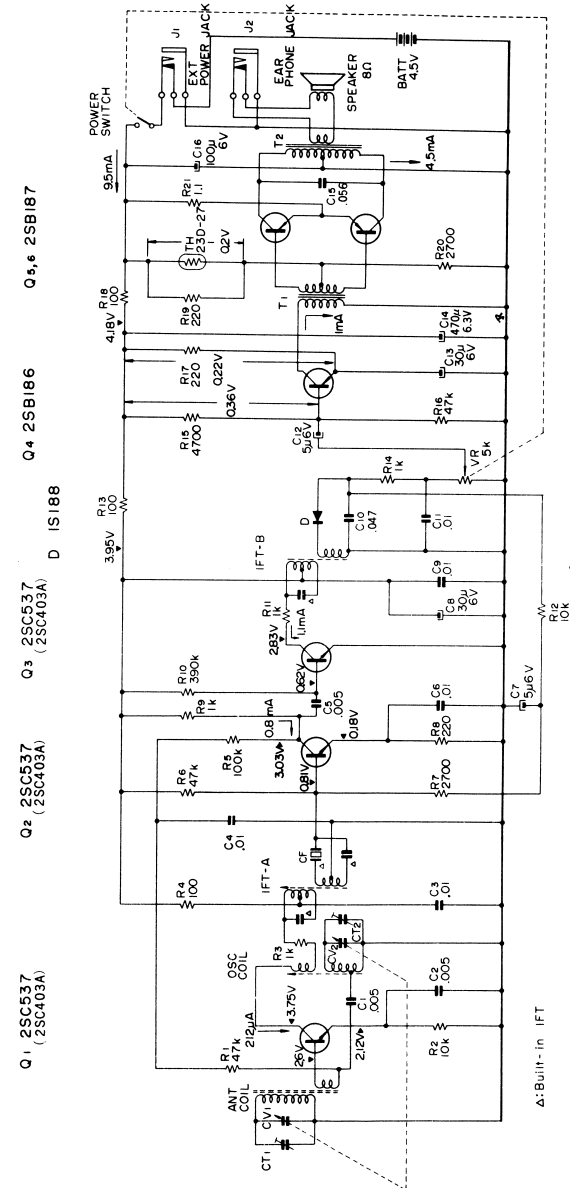

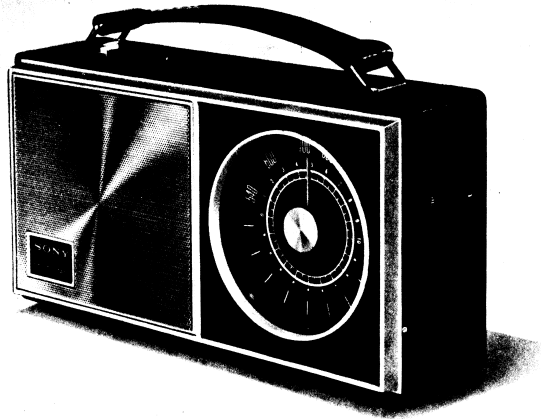

Specifications

- Circuit:** 6 Transistor, Superheterodyne
- Frequency Coverage:** 530~1,605kHz (566~187m)
- Antenna System:** Built-in Ferrite Bar Antenna
- Intermediate Frequency:** 455kHz
- Maximum Sensitivity:** 80 μ V/m
(at 50mW output)
- Power Output:** 200mW (undistorted)
330mW (maximum)
- Speaker:** 3" (77mm) PM dynamic, 8 Ω
- Current Drain:** 9.5mA at zero signal, 70mA at 200mW output
- Power Source:** Three "D" Size Flashlight Batteries, 4.5V in total
or House Current by using SONY AC Adaptor (AC-81W)
- Dimensions:** 8 $\frac{3}{4}$ "(W) \times 5"(H) \times 2 $\frac{3}{4}$ "(D)
(224 \times 128 \times 68mm)
- Weight:** 1 lbs 7 oz (660 grs) with Batteries

Block Diagram

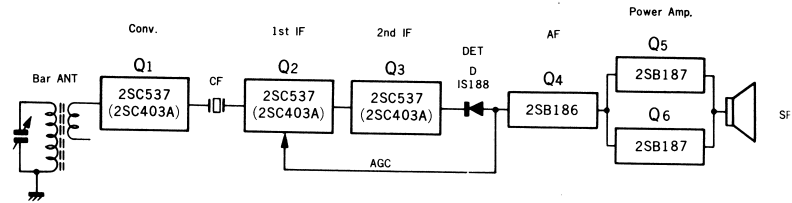

Interior View

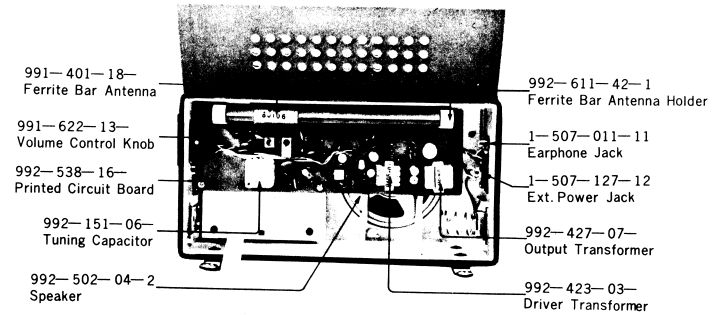

Stringing Dial Cord

