

"S.-C." Models 355, 355A

(Circuit diagrams appear on facing page.)

The circuits employed in these receivers provide a very interesting example of "reflexing" in that two type 6F7 triode-pentode valves are used to perform five distinct and separate functions. The first 6F7 operates as an R.F. and A.F. amplifier, while the second acts as I.F. amplifier, detector, and delayed A.V.C. recti-

fier. Operating voltages for model "355" are as follow:—

6F7, R.F. and A.F. Amplifier. Pent. plate, 275 v.; screen, 100 v.; pent. grid, -1.5 v.; triode plate, 100 v.; triode grid, -18 v.

6C6, Autodyne Frequency Converter. Plate, 275 v.; screen, 100 v.; cathode, 7 v.

6F7, 465 KC. I.F. Amplifier, Detector, and A.V.C. Rectifier. Pent. plate, 275 v.; screen, 100 v.; pent. grid, -1.5 v.; triode plate (A.V.C. rectifier), -1.5 v.; triode grid acts as detector diode.

42, Output. Plate, 265 v.; screen, 275 v.; grid, -18 v.

The major point of difference between the two circuits is found in the use of a type

6A7 as pentagrid frequency converter instead of the original 6C6 autodyne. This necessitates the provision of a 200 v. tapping on the voltage divider for oscillator anode-grid supply. Another change is found in the fitting of a meter-type tuning indicator to the plate circuit of the R.F. amplifier. Finally, an important change has been made in the biasing of the second 6F7. This is now self-biased by means of two resistors in the cathode circuit. The pentode grid is returned to the junction of these resistors and receives a bias of about 2 volts. The remaining resistor in the cathode circuit serves to provide additional A.V.C. delay.

"Stromberg-Carlson" A.C. Broadcast Models 355, 355A

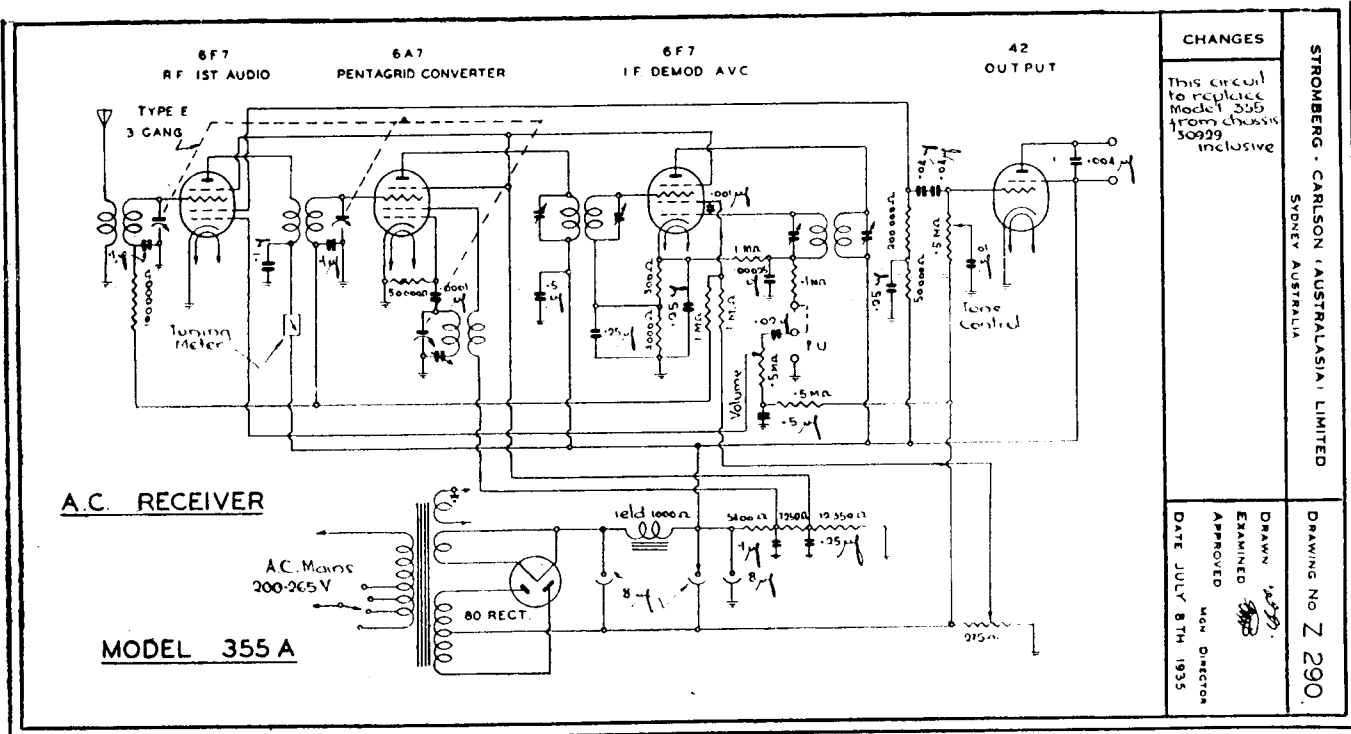
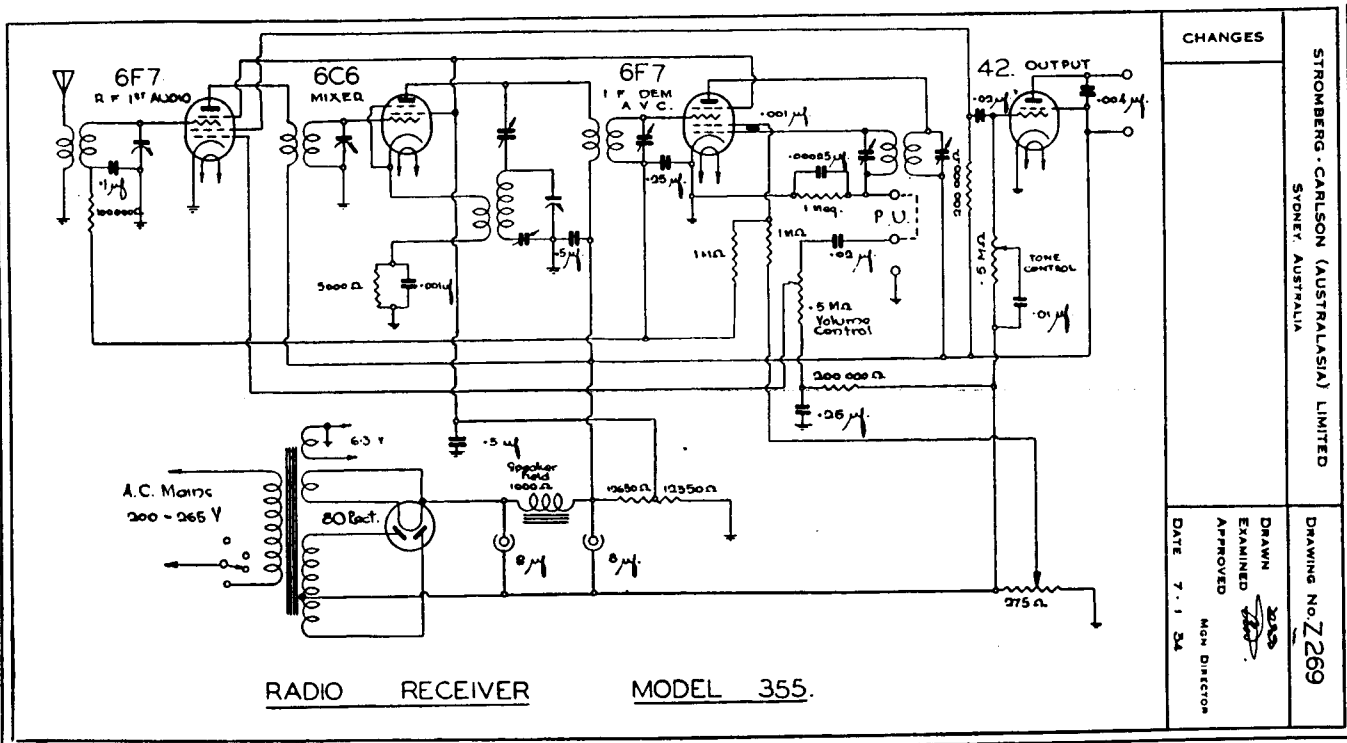

The above two circuit diagrams depict the arrangements employed in the two versions of Stromberg-Carlson Model 355, which appeared during 1934 and 1935. The upper circuit diagram applies for all receivers of this type number which bear serial numbers up to, and including 30928, while the lower diagram applies for all receivers bearing serial numbers above this. Both models were A.C. operated consoles, designed for broadcast coverage, and both employed an I.F. of 465 KC. Further descriptive matter, and operating voltages for model 355, will be found on page 333.