

MODEL II-152

ISSUE I. DATE 12-10-71

SPEAKERS. 8" ROLA CM8X 3-5 Ω V.C. - A
3" ROLA 3DX00 8 Ω V.C. - B

VOLTMETER READING.

ALL VOLTAGES SHOWN ARE RELATIVE TO EARTH NO SIGNAL CONDITIONS USING A 40,000 Ω/V METER

FUSE BEZEL LIGHT.

A WIRED FUSE IN SERIES WITH LAMP SUPPLY IS LOCATED IN POWER SUPPLY ON TAG STRIP ADJACENT TO POWER TRANSFORMER. (0-012" TINNED COPPER)

TR4 BC149 TR5 BC158

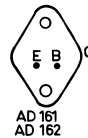
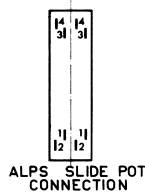
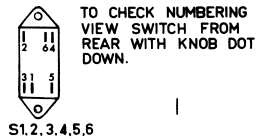
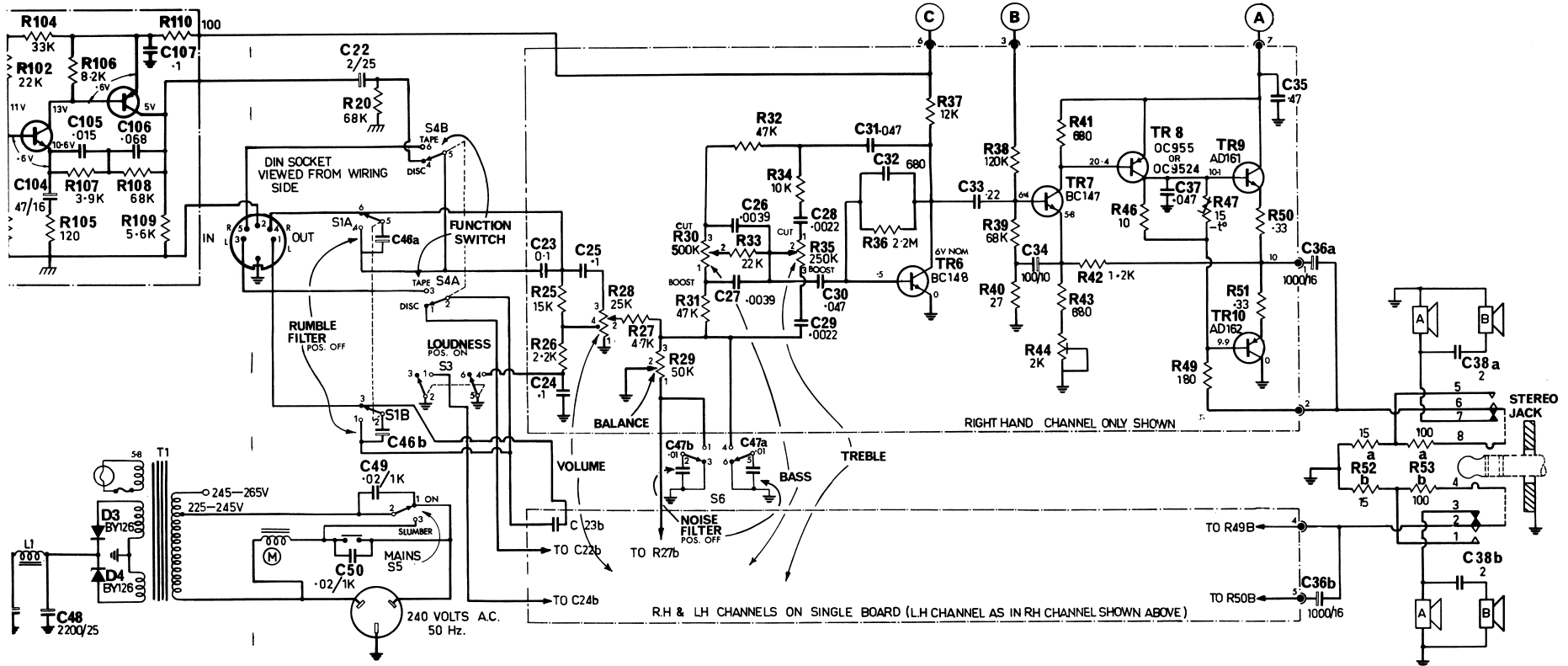

BASE CONNECTIONS

